

UCLA

Cotsen Digital Archaeology series

Title

Who is afraid of basketry

Permalink

<https://escholarship.org/uc/item/7p51v5jz>

ISBN

90-73782-06-6

Author

Wendrich, Willemina

Publication Date

1991-07-01

Supplemental Material

<https://escholarship.org/uc/item/7p51v5jz#supplemental>

Peer reviewed

CNWS

Centre of Non-Western Studies

Leiden University

A guide
to recording
basketry
and cordage for
archaeologists and
ethnographers

WHO IS AFRAID OF BASKETRY

Willemina
Wendrich

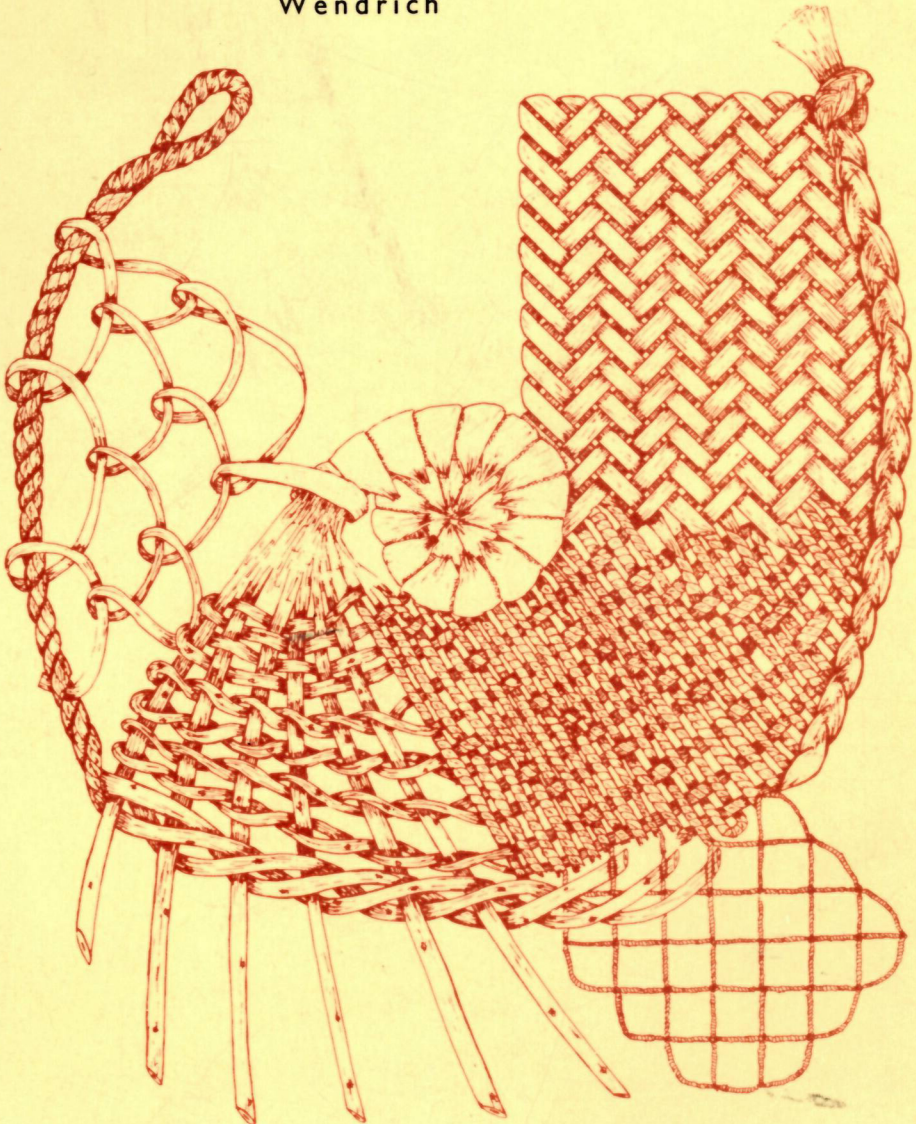

CNWS PUBLICATIONS NO. 6

WHO IS AFRAID OF BASKETRY

**A GUIDE TO RECORDING BASKETRY AND CORDAGE
FOR ARCHAEOLOGISTS AND ETHNOGRAPHERS**

WILLEMINA WENDRICH

1991

**CENTRE FOR NON-WESTERN STUDIES
LEIDEN UNIVERSITY
PO BOX 9515
2300 RA LEIDEN
THE NETHERLANDS**

CNWS PUBLICATIONS is produced by the Centre of Non-Western Studies of Leiden University, The Netherlands.

Editorial board: M. E. van den Berg; R. T. J. Buve; R. Kruk; G. van Loon; W. van der Molen; J. D. M. Platenkamp (chief-editor); W. J. Vogelsang; W. van Zanten.

All correspondence should be addressed to: Dr. J. D. M. Platenkamp, chief-editor CNWS Publications, c/o The Centre of Non-Western Studies, Leiden University, PO Box 9515, 2300 RA Leiden, The Netherlands.

CIP-gegevens, Koninklijke Bibliotheek, Den Haag
Wendrich, Willemina

Who is afraid of basketry. A guide to recording basketry and cordage for archaeologists and ethnographers / Willemina Wendrich. - Leiden: Centre of Non-Western Studies, Leiden University. - Ill. - (CNWS Publications, ISSN 0925-3084; no. 6). With bibl., index.

ISBN 90-73782-06-6

Subject heading: basketry

Design front cover: Nelleke Oosten

Printing: Haveka, Alblasterdam

C. Copyright 1991 Centre of Non-Western Studies, Leiden University, The Netherlands

Copyright reserved. Subject to the exceptions provided for by law, no part of this publication may be reproduced and/or published in print, by photocopying, on microfilm or in any other way without the written consent of the copyright-holder(s); the same applies to whole or partial adaptations. The publisher retains the sole right to collect from third parties fees in respect of copying and/or take legal or other action for this purpose.

When you get down to bone,
you haven't got all the way, yet.
There's something inside the bone...
the marrow...
and that's what you gotta get at.

Edward Albee

CONTENTS

PREFACE (v)

CHAPTER ONE. INTRODUCTION

1. Who is afraid of basketry (1)
2. Definitions (3)
3. Sequence of the chapters (4)

CHAPTER TWO. EQUIPMENT (7)

CHAPTER THREE. LOCATION

1. Introduction (11)
2. Site characteristics in respect to preservation (11)
3. Preservation of the structure: carbonization and stabilization (13)
4. Preservation of the appearance: impressions (13)
5. Related finds (15)

CHAPTER FOUR. STABILIZATION AND RETRIEVAL

1. Introduction (17)
2. Stabilization (17)
3. Site recording (17)
4. Excavation (18)
5. Transportation (18)
6. Consolidation (19)
7. Impressions (19)

CHAPTER FIVE. RECORDING

0. Introduction (21)
1. Identification (28)
2. Technique
 - 2.1. Cordage (30)
 - 2.2. Basketry and mats (47)
 - 2.2.1. Basic structure (48)
 - 2.2.2. Base (72)
 - 2.2.3. Side (78)
 - 2.2.4. Transition base - side, method of shaping (83)
 - 2.2.5. Rim, edge (84)
 - 2.2.6. Other (84)
3. Dimensions
 - 3.1. Cordage (86)
 - 3.2. Basketry (88)
4. Shape (92)
5. Special features (93)
6. Material (98)
7. Condition (100)
8. Treatment (100)
9. Storage (101)
10. Context (102)
11. Use (102)
12. Remarks (103)
13. Two more recording sheets (103)

CHAPTER SIX. SAMPLING

1. Introduction (107)
2. Fibre identification (108)
3. Dating (110)

CHAPTER SEVEN. PRESERVATION AND STORAGE

1. Introduction (113)
2. Cleaning (114)
3. Restoring shape (115)
4. Consolidation (116)
5. Packing (119)
6. Storage (120)
7. Mould and insects (120)
8. Labelling (121)

APPENDIX A. EXAMPLES OF RECORDING SHEETS (123)

APPENDIX B. PLAIT INDEX (129)

APPENDIX C. CONSOLIDANTS (131)

APPENDIX D. HOW TO USE PLAIT-0-METRIC PAPER (133)

GLOSSARY (135)

BIBLIOGRAPHY (147)

INDEX (153)

PREFACE

In September 1986 I started working on basketry and cordage. Since that moment I have lost my innocence. Whenever I see a basket, my brain automatically starts to figure out its technique, material and function. Seventeenth century paintings of Dutch and Flemish masters are suddenly of interest to me, especially if they depict kitchen or market scenes (*ergo* innumerable baskets). Whenever I visit a friend's house, a rustic restaurant, an agricultural museum, I secretly play a private game, called 'spot the basket'.

At the start of my work as a basketry specialist on several excavations in Egypt, I used four different basketry recording sheets which were based on those presented by J. M. Adovasio (Adovasio 1978). During the successive excavation seasons, I felt the need to make several alterations. Working with Dutch and Egyptian basketmakers, and studying basketry techniques from all over the world, presented me with a wider background for the Egyptian archaeological material. This broader perspective required even more modifications and, so I hope, improvements, to the original design. The majority of these alterations stemmed from practical experience. The most fundamental, however, was dictated by theoretical needs: instead of selecting in advance several 'types' of basketry which were to be recorded on four different recording sheets, the new sheets are designed in such a way that every basket and basketry technique can be recorded according to the same parameters.

Discussing my work with several people, both archaeologists and ethnographers, indicated that others would like to use the recording sheets as well. Without a proper description, however, the sheets are absolutely incomprehensible, since they were designed for my own use. My promise to write a short instruction to go with the recording sheets, has led to the writing of this book.

Many people have been important to me and my work. I would like to thank Gillian Vogelsang-Eastwood for pushing me into this profession, Vera Boots for teaching me the shady side of drawing, and Hans Barnard for his many-sided support. He has taken most of the photographs presented in this book, and he has performed a great deal of calculating, speculating and heartening.

A long time ago Richard and Helena Jaeschke (Devon) have given me precious advice on conservation matters, as did Cor Dieleman, T. Stambolov (Central Research Laboratory for Objects of Art and Science, Amsterdam) and Mr. A. J. M. Wevers (Government Department of the IJsselmeerpolders, Lelystad). I would like to thank Olaf Goubitz (Rijksdienst voor Oudheidkundig Bodemonderzoek, Amersfoort), and Tineke Spruyt (Conservator of the Department of Pre- and Protohistory of the University of Amsterdam) for their comments on the chapters which deal with retrieval and conservation. Furthermore, I am grateful to Prof. J. F. Borghouts, Piet van de Velde, René van Walsem, Mia Pot - van Regteren Altena, Gillian Vogelsang-Eastwood and Danielle Geirnaert for reading the manuscript and providing me with many useful remarks and suggestions.

Notwithstanding the valuable contributions of all people mentioned above, I take full responsibility for the text.

Amsterdam, June 1991

CHAPTER ONE

INTRODUCTION

1. Who is afraid of basketry

Archaeologists and ethnographers tend to neglect basketry and cordage. Reports from archaeological sites with large quantities of organic material often fail to mention such finds. Yet there are some recent exceptions. In some cases the sudden "appearance" of basketry seems to coincide with a basketry specialist appearing on the scene. Although basketry clearly is part of material culture, the importance of this class of artefacts as a potential source of information has yet to be generally accepted. To a basketry specialist the value of a certain small fragment might be obvious, to the general archaeologist the use is often anything but clear. This, added to the problems involved in retrieving and preserving organic material in general, leads to the result that basketry is often considered a troublesome, if not negligible, class of artefacts.

However, with a minimum of effort, basketry can be turned from a negligible into a useful object of study. The aim of this book is to offer basic information on how to act and what to look for when basketry remains are found. The familiarity with the material thus gained, will facilitate an initial judgement of the objects. The book is intended for those archaeologists and ethnographers who expect to find basketry as part of the material culture under study. Furthermore, it can serve as an introduction to basketry for students of archaeology and cultural anthropology, who want to specialize in this field. The technical details may be of interest to modern basket makers. Museum staff of both ethnographic and archaeological museums may find it a useful guide to the description of their basketry collections, which are often insufficiently recorded.¹

¹ In The Netherlands a project was started in 1989 to describe local Dutch basketry techniques which survive in museum collections. The specific objective is to preserve the knowledge on basketry techniques for later generations. A second objective is to enable modern basket makers to make reconstructions based on information which is recorded by the method described in this book. The project is being conducted under the aegis of the Stichting Wilg & Mand, IJsselstein, The Netherlands.

This book is not meant to be the definitive work on basketry and cordage. Nor does it pretend to be a handbook for basketry specialists. A specialization in basketry not only requires detailed training in recording, but also a complete awareness of the methodological consequences of recording, analysis and classification. Although a brief introduction to these essential aspects is included in the introduction to Chapter Five (p. 21), the subject cannot be discussed in detail within the scope of this book.

Current literature on basketry and cordage is limited and deals mostly with ethnographic basketry. The subjects range from world-wide inventories of basketry techniques to case studies and museum catalogues.² Archaeological literature can be divided into inventories of basketry from specific sites (for example Gourlay 1977) and inventories of basketry techniques within wider contexts (for example Bobart 1971).

To date the only book on the recording of basketry within an archaeological context is *A Basketry Technology*, by J. M. Adovasio (1978). Despite a number of shortcomings, this book presents a thorough introduction to the recording of basketry, based on finds from North American Indian sites. The book is clearly structured and the drawings are excellent. However, the book is extremely detailed and therefore difficult to use when trying to grasp the basics of basketry. This makes it more useful to basketry specialists, especially those working in North America, rather than to general archaeologists, students and museum staff. A second drawback is the fact that Adovasio's recording method is not wholly consistent. He stresses the particular aspects and technical details which he found among his North American Indian material. Such an approach leads to a certain bias caused by regional peculiarities. This is perfectly acceptable as long as such peculiarities do not affect the basic recording method. In *A Basketry Technology*, however, the recording is based upon the variety of techniques which were recorded by Adovasio during his research. Hence, the number of techniques which fit into the system is limited. The recording system lacks flexibility, and when used elsewhere it may be impossible to include all of the local techniques.

Thirdly, Adovasio's approach to the analysis of basketry is fully directed by his recording method. Only three major groups or classes are taken into account. This division is not based on a consistent distribution according to certain aspects, but by a traditional ranking of the techniques identified. The three groups

² A discussion of the literature on the subject can be found in Nettinga-Arnheim 1977:9-18.

correspond with three generally known basketry terms: coiling, twining and plaiting. Adovasio's taxonomical approach is attractive at first sight, since it maps out the total range of observed techniques and their positions in the system. However, in my opinion this method of classification presents a serious problem. In the first place the classification is based on a limited number of specimens, rather than on a combination of relevant aspects. Only the latter method allows for all possible variations. Secondly the analysis, of which the classification is a component, is not performed on the basis of an explicit question (see Chapter Five, section 0).

The method which is presented in the following chapters intends to provide a general basis for basketry analyses and classifications as well as for recording data.

2. Definitions

Cordage is defined as a class of artefacts consisting of vegetable fibres, which have been worked into uniform cylindrical strands of unlimited length, as well as artefacts obtained by knotting such strands. Cordage thus comprises artefacts made by a set of techniques of which the combination of spinning and plying is the most common. Ropes and cords are artefacts which are included in the definition. In many cases these are only a half-product for other artefacts, such as nets; hobbles for cattle; belts and sandals; brooms and brushes; mats and bags.

The adjective *cordage* is used to indicate a group of techniques which is confined to knotting and binding. Hut constructions in which the joints are tied with rope, are considered to be made with the help of a cordage technique. The same applies to mats which consist (partly) of string.

A *knot* is any construction made out of string, which is made according to a scheme or plan. In general this scheme is known to several people in a society. The term knot includes a great variety of string constructions, such as *knob knots*, *bends*, *hitches* and *splices*.³

³ A knob knot is a knot at the end of a rope, which prevents the rope from unravelling. Knobs are often used as stoppers. A bend is a knot which connects two different lengths of string. A hitch is a knot tied to another object (for instance a pole). If the object is removed the knot disintegrates. A splice is a connection made by plying or cabling together the unravelled ends of two ropes, or a method of stopping a rope from loosening by plying or cabling the unravelled end of a rope back into itself (Ashley 1960:12).

The term *basketry* will be used as a class of artefacts made out of vegetable fibres of limited length or with a shape which is specific to the raw material. Basketry thus defined comprises baskets; bags and mats; brushes and brooms; hurdles, wattle-and-daub constructions; sandals; hats, and belts.

Several functional categories, such as mats, belts and bags, are included in the lists of both cordage and basketry items. These objects are made in techniques in which both material of unlimited length (cordage) and raw material of limited length (basketry) occur.

If we define basketry as "products in which raw materials of limited length and plant-specific shape are incorporated", and *textiles* as "products which consist of raw material or half products of unlimited length and uniform shape", cordage is a half product for both textiles and basketry.⁴ The first reason, therefore, to include a chapter on recording cordage techniques is that cordage is incorporated frequently in basketry. An additional reason is that the raw materials for cordage and basketry are often identical.

3. *Sequence of the chapters*

The general purpose of this book is to present a general introduction to the recording of basketry and cordage. Although methodological matters are important, they will only be mentioned briefly in Chapter Five. The specific objective is to provide a practical approach to dealing with basketry in the field, the emphasis being on recording. The different aspects of recording are dealt with in Chapter Five, which constitutes the central part of this book. The chapter is embedded in a number of shorter chapters on the treatment of basketry in the field.

Chapter Two (EQUIPMENT) lists the basic equipment needed for the recording of basketry and cordage. Chapter Three (LOCATION) discusses the conditions in which basketry and cordage survive, as related to the type of sites where these artefacts can be expected. Chapter Four (STABILIZATION AND RETRIEVAL) considers the measures necessary to stabilize the condition of the object and the isolation from the archaeological context. The retrieval of the artefacts and - ideally - their transfer to a laboratory precede RECORDING,

⁴ In these two definitions, the difference between textiles and basketry techniques is based on two aspects. In the first place there is a difference in length and shape of the raw material. Secondly textiles consist solely of strands of unlimited length or uniform shape, while basketry may consist of a combination of long uniformly shaped strands and strands of limited length or specific shape. The raw material influences the technique applied (see Wendrich 1990; Wendrich 1991).

which is the subject of Chapter Five. SAMPLING (Chapter Six) should be performed next, as the samples will be rendered useless by any treatment applied. The last step is PRESERVATION AND STORAGE (Chapter Seven).

The chapter sequence corresponds roughly to the ideal order of the work in the field. In practice it is often necessary to deviate from this order. Recording starts, obviously, with the registration of the position of the object *in situ*. However, it is sometimes impossible to lift the object out of its context without consolidation, in which case both recording and sampling should precede the retrieval. Also, it may be impossible to record objects properly without minor treatment, such as cleaning. Here, as elsewhere, practical considerations will sometimes take precedence over theory.

CHAPTER TWO

EQUIPMENT

The basic equipment for the recording and treatment of basketry consists of a limited set of tools, which can be gathered in one container, such as an equipment roll. In this way the tools are ready at hand and can be easily transported. In Table 1, two separate columns list the standard equipment and the supplies. The supplies should be replenished after each expedition. Since each object or fragment is recorded on a separate recording sheet, the number of sheets needed has to be carefully estimated before going out into the field or visiting a museum collection.

In order to examine the technique, condition and material of an object, tools such as surgical pins and tweezers are used. In general it is best to touch the objects as little as possible, since grease stains or the smallest food remains easily attract insects. A small mirror is used to inspect the backside and base of fragile objects. A dentist's mirror is extremely useful. Magnifying glasses, especially with a built-in light source are essential for examining both technique and raw material. A low magnification (30x) pocket microscope on batteries is very useful.

String in different colours can be used to check reconstructions of knots. Especially fragile knots from archaeological sites cannot be examined by slightly loosening the knot, as can be done with modern knots, since the material would not survive the strain of pulling the strands. After careful probing, the knot thus has to be reconstructed in drawing. The string is then used to check the drawing on consistency and feasibility.

A tape measure is suitable for measuring the circumference and height of larger baskets. The careful measurement of smaller baskets and of certain details, such as the width of the raw material, has to be carried out with callipers. A pocket calculator is useful to make several indices, such as the Cord Index (see pages 33-39) and the Plait Index (see pages 66-68).

Photography during field work requires not only a proper mirror reflex camera and a tripod, but also a portable photographic studio. A plain background, made from crease resistant cloth or coloured cardboard, is essential for

| task | equipment | supplies |
|------------------------|--|---|
| examining | surgical pins* tweezers* small mirror* low magnification hand lens (10x)* pocket microscope (30x)* 6 strings in different colours (40 cm.)* | recording sheets gloves |
| measuring | tape measure* calipers* pocket calculator* | recording sheets |
| photographic recording | camera and tripod photographic scales background (plain cloth or cardboard) lettering/numbering stencil .35 and .70* | black/white film, 100 ASA colour slide film, 64 ASA batteries for camera/flash |
| drawing | drawing pens (gauges: .18 / .35 / .70)* compasses | pencils, rubber, sharpener* colour pencils* drawing ink* graph paper isometric drawing paper drawing film plaiting grid masking tape |
| cleaning | various brushes* tweezers* low power vacuum cleaner small hose pipes: diameter 1 mm. / 5 mm. | cotton swabs* litmus paper strips* 95% ethanol |
| restoring shape | bell chamber (or improvised equivalent) | acid free tissue paper |
| sampling | scalpel no. 3* scissors (two sizes)* | scalpel blades no. 10 / 11* single edge razor blades gelatine capsules no. 000 small polythene bags (sticky) labels |
| fibre identification | low magnification hand lens (10x)* pocket microscope (30x)* | |
| conservation | brushes* vacuum sealer | |
| storage | smyrna needle* needle threader* stapler | labels water resistant felt tip pen* acid free tissue paper acid free bags acid free cardboard boxes sticky tape insecticides / anti-mould needle and cotton* pins* staples* |

Table 1. List of equipment and supplies needed for recording basketry. The tools which have been indicated with an asterisk are part of the standard equipment.

object photography. Of course scales have to be included in each photograph, together with the object number.¹ If the decision is made not to include numbers in the photograph, then a precise photographic logbook should be kept which will identify each photographed object. This system is not fool-proof.

Since many publishers either demand black and white film or colour slides, these two types of film are to be preferred above colour print film.

The drawing of the technical details is even more important than photography. Pencils for sketches, and drawing pens (a collection of at least three gauges) for more permanent drawings, and coloured pencils for indicating the different strands in the drawings form the basic drawing equipment. It is worthwhile to take graph paper and isometric drawing paper out into the field, since especially the complicated reconstruction drawings need the presence of the object to check and re-check the drawing. For the same reason it is preferable to make all permanent drawings in the field. The sketches on graph paper and isometric paper can be copied on transparent drawing film, which is held in place with masking tape.

An example of graph paper with a grid, especially designed for drawing patterns of plaiting, is included in this volume.

A collection of paint brushes and differently sized tweezers is necessary for cleaning the objects. In some cases, brushes, even the very soft ones, leave traces on the surface of the object. A low-power vacuum cleaner, for instance the type used to clean electronic equipment such as record players, is especially useful when dealing with fragile, dry material.

In the case of waterlogged material it is advisable to clean the object with a submerged hosepipe in a water bath. The basic supplies for cleaning basketry are ethanol 95% and water. This can be either distilled water, or in any case, acid neutral water. The acidity of water can be tested with litmus paper strips. Cotton swabs are used to apply both water and ethanol (see Chapter Seven, section 2).

A glass bell chamber can be used to restore the shape of dry material. The chamber allows for slow humidification of the object until enough flexibility is restored to mould the basket gently back into its original shape. The bell chamber often has a more improvised character in the field (see Chapter Seven, section 3).

¹ In order to give a more professional touch to the photograph the numbers have to be uniform. The lettering can be made, for instance, by using letter stencils, which are included in the equipment roll.

Acid-free tissue paper is used to support the object in the right shape and for storage.

Samples are taken by cutting a fragment at a non-conspicuous part of the basket with a single-edged razor blade or a scalpel. The samples are then labelled and stored in small polythene bags or large gelatine capsules. The identification of the samples has to be performed in a well equipped laboratory.² A field laboratory rarely includes all the necessary facilities. Moreover, the often limited amount of time available does not allow for time-consuming techniques such as fibre identification. Thus the only equipment that is really needed in the field is a low-power magnifier in order to obtain a preliminary impression of the material involved, without attempting to decide on the exact species. Because conservation is best performed in a laboratory, the equipment needed for conservation is not listed in Table 1. Even first-aid conservation requires extensive laboratory equipment. Beakers, weighing scales, a bunsen burner, are all things that are normally present in a laboratory, but which require extra costs and organization when used in the field. In addition, many solvents present a health hazard and should not be used outside a fume cupboard. A vacuum sealer is a useful tool in preserving dry basketry (see Chapter Seven, section 5).

For storage it is essential to calculate accurately the amount of supplies needed. Cardboard boxes, tissue paper and bags all have to be acid-free. Needles and cotton, pins and stapler are used for making tissue paper supports for the baskets. All objects have to be labelled with their individual basketry number and the site/context/museum numbers. Attention should be paid to the permanence of the labels (water resistant felt-tip pens). Smyrna needles and needle threaders are of some help to anchor the labels steadily in the basketry structure, without damaging the basket.

² The minimum requirement for fibre identification is a magnification of 600x. For studying cross sections one will need mounting agents, colouring agents, a microtome and a series of Petri dishes.

CHAPTER THREE

LOCATION

1. Introduction

Nowadays plastic and cardboard have to a great extent replaced basketry. Yet, if we look around us and consider the amount of plastic containers that feature in our lives, we can gain some idea of the amount of basketry that was used in many ancient societies. Considering this, it is obvious that large quantities of basketry were originally deposited at almost all archaeological sites. Depending on the preservational circumstances, some archaeological sites indeed render basketry and cordage in considerable quantities, and in remarkably good condition. Other sites only have a few fragments of basketry, usually in very bad condition. Especially at those sites it is of the utmost importance to remember that the basketry finds constitute a tiny fraction of the originally deposited quantities and that the range of materials and techniques applied probably was much wider than the study of the extant material may lead to think.

The difference in the number of retrieved objects has limited effect on the time that has to be spent on them. At sites with large quantities of well preserved fragments most of the time is used for recording, with very little effort directed towards conservation. At sites where only a few fragments are preserved all the effort is used to stabilize and conserve the objects.

Not only the finds of basketry and cordage fragments provide information on the techniques and artefact distribution. Impressions and fossilization are other forms of preservation of basketry. There are also related finds, such as instruments for basketry production, which may complete the picture.

2. Site characteristics

In all cases the preservation of organic materials is due to exceptional circumstances. The only reason that organic materials do not perish is the fact that the environment is hostile to forms of life. Bacteria and fungi do not survive and therefore basketry and cordage remain intact.

The preservational circumstances can be divided into four major groups: wet, waterlogged, permafrost and dry. Wet sites are those places at which the soil is intermittently wet and dry, as a result of rainfall, fluctuations in the level of the ground water, or inundations. Such changes are destructive for basketry and cordage. Thus, the condition of basketry and cordage at wet sites is extremely bad, if anything survives at all. If parts of a wet site are permanently waterlogged, basketry and cordage may be found in a slightly better condition.

In waterlogged, or permanently wet circumstances the objects are closed off from oxygen and in such an anaerobic environment the objects are well preserved. Especially peat bogs yield excellent preservational circumstances for organic material. Thus basketry and cordage can be found at completely waterlogged places, but also at waterlogged areas of wet sites, such as old wells, ditches and harbours. Generally, the objects deposited in these circumstances are either those designed to be used in the water, such as fish traps and nets, or objects that were discarded into the water. Good examples of such conditions are wells which fell into disrepair in antiquity and were re-used as rubbish pits. Shifts in coastline can even cause the preservation of complete settlements. At such places one can expect to encounter the entire range of basketry and cordage artefacts.

The preservational circumstances of organic materials are excellent in permafrost sites. Since those sites are situated in areas where the raw material for basketry - defined as being made out of vegetable fibres - does not grow, the raw material or the complete baskets were imported. Certain local artefacts made of leather or sinew may resemble basketry, as far as the technique is concerned.

Dry sites are those sites without any rainfall or other forms of precipitation. Such extremely dry circumstances occur in deserts, rock caves and tombs. Dry sites usually produce considerable quantities of well preserved basketry and cordage. Examples of desert sites which have partly changed into wet sites, however, show that originally well preserved basketry and cordage objects deteriorate within a few years when exposed to humidity.¹

¹ A good example is the Egyptian site of Qasr Ibrim, a former fortified town which was inhabited from the New Kingdom to the Islamic period (1500 B.C. - A. D. 1820). The fort was situated high above the cliffs along the River Nile, 200 km south of Aswan. With the building of the Aswan High Dam, the Nile valley turned into a lake and Qasr Ibrim became an island. The water level in the lake fluctuates, the highest level being reached in winter when the rain water from Sudan arrives in the lake. The layers which are affected by this change in water level still contain remains of basketry and cordage, but the condition of the objects is extremely bad compared to the specimens that have remained dry since their deposition.

As with all other sites, the range of artefacts from desert sites depends on the type of excavation. A king's tomb yields a different collection of baskets than a workmen's village. The complete specimens of very fine, decorated basketry from tombs tell a different story than the collection of fragments from the village dumps. In both cases, however, the exceptional preservation circumstances guarantee that a considerable percentage of the deposited material have survived.

3. Preservation of the structure: carbonization and fossilization

Special forms of preservation are carbonization and fossilization. Carbonized and fossilized fragments survive at both dry and wet sites. Although difficult to recognize, because the appearance of carbonized material is very similar to charcoal, the structure of an object can often be reconstructed by carefully examining the carbonized remains.

Fossilized basketry and cordage fragments are those fragments in which the organic elements have perished, but the structure remains due to an exchange of material with an object deposited in the vicinity. Usually it concerns corrosion of metal objects, which set free minerals that intrude into nearby basketry artefacts, replacing the fibre structure by corrosion particles. Thus the structure of the basket survives even if the object itself has decayed.

The carbonized and fossilized remains are valuable in plotting the range of techniques at a site. However, since the preservation is totally random, great care should be taken with the interpretation of such finds.

4. Preservation of the appearance: impressions

Impressions of basketry and cordage can be found at wet, waterlogged, permafrost and dry sites. The impressions can be divided into two major groups. The first group is that of the post-depositional impressions: although the actual object has not survived, the impression witnesses the exact spot of the original deposition. The technique, and sometimes even the size and shape of the basket, can be inferred from the negative. Post-depositional impressions are to be found in the natural soil surrounding the object, or in layers of mud or plaster that were affixed to the artefact on purpose. An example of such occurrence is the negative of roof matting which survives in the mud layer of roofing remains.

Secondly, there are impressions which were made before deposition. These basketry negatives, however, do not prove the occurrence of the original at the find spot. The impression might have been made elsewhere before being imported

to the final deposition site. The basket might never have been present on the spot. The pre-depositional impressions are either purely incidental or caused by a specific manufacturing process in which basketry is involved. An example are the impressions of mats on the base of pots. These occur whenever the unbaked pots have been resting on mats, either during the throwing of the pot on the wheel, or in the course of the drying process. Impressions also occur on pot bodies. String, for instance, is used both for hand-made pottery, as a support in the process of shaping the body, and for wheel-thrown pottery, as a support for a flaring body or rim.²

An impression of a basket on the outside of the pot may indicate a special way of ceramic production, by either rolling the pot on a mat, during the beating of the clay (Bonnet 1990:234), or by using a basket as a mould in which the clay is pressed into the right shape. This procedure is often only detected by chance, since the basketry impressions on the outside of pots often are covered by a slip layer. Only pots or sherds from which this layer has flaked off display the negative of the original basket (Van Loon 1978:120, plate 141,4).

Other pre-depositional impressions may be found in clay, mud, sand or gypsum layers, in which basketry was temporarily put down before being lifted up again.³ It should be noted once more, that the random character of these data should be taken into account when interpreting the finds.

² String impressions on pot bodies are found most often on hand-shaped pots, in which the string is used as a means of support during the shaping of the pot. A clear explanation of this procedure can be found in Van der Leeuw 1976. Furthermore, string is tied around the rim and flaring sides of wheel-thrown pots, with a similar objective: support of the shape during the period of drying. The string is taken off just before firing (Blackman 1927:150-151). Sherds from wheel-thrown pots which do not need support (e.g. pots without flaring sides), sometimes show string impressions as well. This is a purely decorative application of the pattern derived from the traditional habit of supporting the pots with string. Furthermore, evidence for purely decorative string patterns is found on pot sherds in which the pattern was made with a bone tool, and on stone vases in which a string pattern is engraved (e.g. Fouilles Françaises nos. 27 and 28, p. 29, no. 40, p. 35).

³ An example of such a pre-depositional impression are string impressions found in the gypsum foundation layer for the stone blocks of the temple floor of the Smaller Aton Temple at Tell el-Amarna, Egypt. An example of fine basketry (or coarse textiles!) has been found in a gypsum layer at Kom el Nana, also part of the city of Tell el-Amarna.

5. Related finds

A number of related finds can be used to indicate the presence of basketry and basketry manufacture. These are bundles of material which have been prepared for application in basket work, as well as basket makers' instruments. Such instruments are, for instance, awls, bodkins, knives, needles, rapping irons or wood splitting devices. Even when no basketry objects or impressions are present these finds might indicate a centre of basketry manufacture. The related finds, however, range from specific tools, such as rapping irons, which are designed exclusively for beating down the sides of a wicker basket, to more general tools, such as knives and awls. The interpretation of instruments as specific basketry tools therefore should be based on the techniques and materials which occur at the site.

CHAPTER FOUR

STABILIZATION AND RETRIEVAL

1. Introduction

An ethnographer who has decided to collect basketry is usually in the privileged position of dealing with objects which are still in use and probably in good condition. This chapter deals, therefore, with archaeological material only. With the find of organic material, usually a number of problems arise. Even when the answers to these problems, as presented in this chapter, are simple and cheap, the situation in the field might require even more basic solutions. Field archaeologists, pressed for time and money as they generally are, will perhaps have their own methods in dealing with organic material. In any case they will have developed the inventivity to find solutions to the basic requirements, as indicated below.

2. Stabilization

When basketry or cordage is discovered, the most important action to be taken is to maintain the current condition of the object. This means that wet basketry should be kept wet by regularly spraying the finds with water. Permafrost finds have to be kept cool and wet, and out of the sun. Dry basketry should be kept dry, and preferably out of direct sunlight. Ideally a basketry specialist should be present who can be called in to decide on the importance of the find and the strategy to be followed for retrieval.

The sequence for further treatment is: site recording, excavation and transportation. During all these actions care should be taken that the environment of the artefacts is kept stable.

3. Site recording

The recording of the position of the find *in situ* will generally be done automatically by the site supervisors who note down the position of the individual units or loci. Additional information can be added to the basketry recording sheets, such as related finds and the characteristics of the unit and square. Photography is

important at this stage, not only in order to record the exact position of the artefact, but also to provide information about its condition. A centimetre scale and a specimen number should be included in the photograph.

When dealing with waterlogged and permafrost basketry, care should be taken during recording and photography that the objects are regularly sprayed with water.

4. Excavation

Great care should be taken with the excavation of basketry and cordage. The use of metal tools such as trowels should be avoided, applying brushes instead. When the object is more or less isolated from its context the decision should be taken whether it is safe to remove the soil gathered inside the object. This is often necessary before a basket can be lifted, but removal of encrusted mud or salt deposits can also cause the collapse of the basket. Removing the accumulated material from inside the basket should be done with great attention to possible remains of the ancient contents, which can give a clue to the original function of the basket.

When the object is in a reasonable condition it can be lifted right away. Handling archaeological basketry, however, is very different from dealing with modern basketry. The objects should never be lifted by the rim or the handles and it is important that the base is supported at all times. It might even be necessary to replace the contents by polythene or acid free tissue paper in order to avoid collapsing of the basket by the burden of its own weight.

For basketry and cordage which are in a bad condition it might be decided to lift the surrounding soil together with the object. In some cases this might even require consolidation of either the object or both the object and the surrounding soil (see section 5).

With respect to carbonized fragments the decision has to be taken whether the time consuming task of excavating the delicate specimens with surgical pins and brushes can be performed on site, or whether this task should be performed in a (site) laboratory. In the latter case, the fragments are lifted together with a considerable amount of surrounding soil.

5. Transportation

Ideally the transportation to a laboratory for further recording and proper conservation constitutes the next step after lifting the artefacts. If it is decided that

the specimens are kept, they have to be packed for transport. The packing of waterlogged and permafrost basketry should help to maintain the find circumstances. Packing in cling film and several layers of polythene prevents the material from drying out. If a period of more than two days is likely to elapse between the excavation and the further examination of the object, it is important to protect the material against fungi and mould. This can be done by including a fungicide, dissolved in the water. In this case sampling should precede the packing, because the fungicide renders the samples useless for certain forms of analysis. Therefore, preferably nothing should be added to the objects, using storage at low temperatures (about +4°C.) to prevent the growth of mould and fungi instead.

6. Consolidation

If it is necessary to consolidate the object or even an entire quantity of surrounding soil, this can be done by the application of a resin (see Chapter Seven, section 4). Before this is done, however, sampling should have been completed, because the consolidant may affect the analyses. The resin can be applied after thorough cleaning the object. It is important that the consolidant is reversible, especially if proper conservation should be performed at a later stage.

Field conservation is in fact nothing else but postponing the loss of the object long enough to make recording possible. Field conservation usually complicates the proper conservation, since the resin applied has to be removed before the final treatment can be given, and every extra treatment is a hazard to the object.

7. Impressions

Either the impression is preserved itself, if necessary by consolidating the earth around it, or a cast is made. The making of a cast has an additional advantage, since the result is a positive of the impression and thus an image of the original object. The casting material should be separated from the impression. Separators which are widely available are soft soap and talcum powder, which can be used in combination with plaster of Paris, or gypsum, to make the positive. Colouring the plaster of Paris with an earth-tone pigment (e.g. Sienna) brings out the details

more clearly.¹ If the impression is brittle, it has to be consolidated first, for instance with a PVC resin (see Chapter Seven, section 4). Great care has to be taken not to change the impression while applying the consolidant. In case of fragile impressions, spraying is preferable to application with a brush.

¹ More detailed descriptions of how to make moulds and casts can be found in Dowman 1970:82-85 and 106-115, and in Sease 1987, Appendix I.

CHAPTER FIVE

RECORDING

0. Introduction

Recording versus analysis

The recording of basketry is not the same as analysing basketry. Recording entails the collecting and storing of information. Analysis is the next step: processing the collected data to find the answer to a specific question. There is therefore no such thing as "the" basketry analysis. In fact there are as many analyses as there are questions. An analysis always includes, albeit often implicitly, a selection of certain aspects which are supposed to give information related to the question posed. The basic question plus the analysis in their turn also determine the type of information which should be collected.

In a scientific approach, the basic question should be made explicit, thus determining the type of analysis and the specific information to be recorded. For instance, in research on basketry in connection with trade routes, the distribution of techniques and the use of raw material are important aspects, and the researcher will gather the specific information which deals with those aspects. When studying the meaning of decorative patterns in basketry, however, the aspects of technique and raw material are subservient to that of colour and decoration, and the particular information to be recorded is thus also different. The object of study is in both cases basketry, but the analysis and the type of data to be recorded are determined by different questions.

Classification is similarly determined by an explicit question.¹ The aspects which are of importance in respect to a specific question are cross-referred in order to determine all possible combinations. Then the combinations which occur in reality are fitted into the classification. An example of such a classification is

¹ Two important textile classifications, which both include basketry, vividly illustrate the fact that classification is question-based. The systems of Emery (1980) and Seiler-Baldinger (1973) both classify textile techniques, the first according to the basic structure, the latter according to the production process.

illustrated in Figure 1. In this scheme two aspects are plotted, namely *numbers* and *letters*, each with three *attributes*. The result is a two-dimensional classification: a classification according to two aspects, or dimensions, which are considered to be equally important. Each dimension shows a variety of attributes. In this case both dimensions have only three attributes: '1', '2' and '3' for the numbers; 'a', 'b' and 'c' for the letters. A *class* is defined by a specific combination of two attributes, one of each dimension. All possible combinations are shown in the diagram, but not all combinations occur in reality. There are a number of empty classes. When a third aspect is involved we obtain a three dimensional classification. Such a classification, with the aspects letters, numbers and Latin numbers, has been plotted in Figure 2, each class consisting of a different combination of three attributes.

By developing such a classification based on basketry aspects, the collection of baskets which has to be analysed can be placed in an explicit order. Thus the relative position of different baskets can be determined. In this way it can be made clear that two baskets are different or similar. More importantly it can also be indicated exactly in what way and to which degree they differ or correspond.

The total number of aspects which could be relevant for basketry is much more extensive than the example in Figure 2, which only involves three aspects, with three attributes each. The multitude of relevant aspects when dealing with basketry (and indeed most artefact classes) displays the weakness of this type of classification, in which each aspect is involved and every aspect is considered to be of equal importance. If we would determine all possible relations between all possible attributes, something which can be done with a computer, we obtain a result which does tell us something about the occurrence and omission of certain combinations of attributes. However, it is not really clear exactly what it is telling us. Such a classification is not very useful.

The central issue in classification is the selection of dimensions which will be used, namely which aspects are considered relevant for the research question at hand. For example, for the relation between the choice of material and technique, a six-dimensional classification can be made, in which one dimension contains information on the raw material, and five dimensions contain information on the technique. This operation results in "a" basketry classification which involves only six aspects. For some questions it is useful to create a hierarchical order and thus give more weight to some aspects than to others (Dunnell 1971). A pilot study can be made on a sample of data, in order to determine the relevance of such a classification to the research question. The relevance is thus determined *a posteriori*.

| | | | |
|---|-----|---|-----|
| | 1 | 2 | 3 |
| a | 1 a | | |
| b | | | 3 b |
| c | 1 c | | |

Figure 1. A two dimensional classification, in which the aspects involved are numbers and letters. The attributes of the two dimensions, three numbers and three letters, are cross-referred. The result is a classification which exists of nine classes. Only three classes do occur, the other six classes are empty. Both aspects, numbers and letters, are considered to be equally importance.

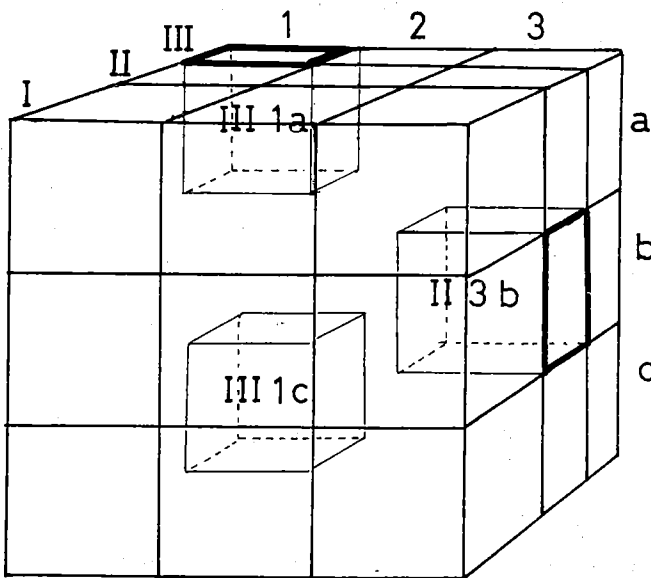

Figure 2. A three dimensional classification, in which the aspects are numbers, letters and roman numbers. All aspects are considered to have the same importance. The attributes, three numbers, three letters and three roman numbers, are cross-referred. The result is a classification which exists of 27 classes. In this example only the combinations III1a, II3b and III1c (three classes) do occur, the other 24 classes being empty.

Classification in this way can be used as an analytical tool. This is only possible, however, if the classification is based on an explicit question. It then has to be decided which aspects are of importance in relation to the question. Secondly it has to be decided if any of the selected aspects should be given more weight than others and why this should be so.

As in every analysis, there are three levels of information: data, inferences and judgements (Figure 3). The *data* are derived directly from the object. These are factors that can be retrieved empirically: measurements, shape, technique, material. The data are gathered by recording, which forms the main subject of this chapter. The selection of those aspects which are considered relevant and others which are not, is again based on the research question. Thus the database is not an objective source of information, but an explicitly selected pool of information which has to be adjusted time and again in interaction with the results of previous investigations. The objective of recording every possible aspect is impossible and, furthermore, of no use. For example, one of the aspects that has not been included in the recording sheets is the present smell of basketry fragments. This dimension is considered to be of no consequence to the range of questions that the researcher has in mind. The omission is the result of a question-based selection and at the present state of the research project, not considered a loss of information.

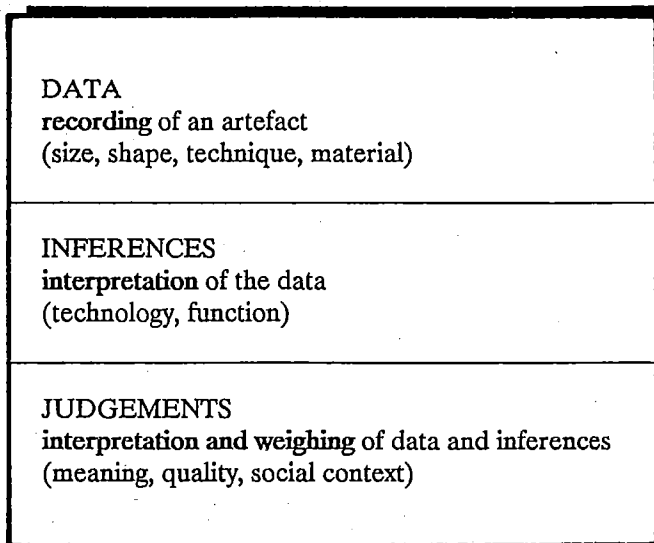

Figure 3. Three levels of information processing.

Other aspects can be inferred from the data. These aspects are for instance function and technology. Determining the *use* or *function* of a basket always involves the interpretation of data. *Technology*, as opposed to technique, is the knowledge which is needed to produce a certain technique. Technological aspects are the use of tools, the production sequence and the physical position of the basketmaker. Traces and edges can be interpreted as resulting from a certain use of tools. When we are not dealing with complete objects, but with fragments, we have to infer aspects such as the shape and measurements of the original basket. Although they are classed as data in Figure 3, these aspects are not readily available when dealing with small fragments. Inferences are derived by analysis.

The third level of information is the judgement of data and inferences. Both inferences and judgements require interpretation. The difference between the two is the complexity and the grade of speculation involved. Inference is an interpretation based on a limited number of aspects. Judgement is a weighing of a complex number of aspects, in which some are very important, others contribute little. Judgements can be given on quality and meaning of the artefacts, but also on the social context of the user and producer of the artefacts.

In this book we are only concerned with the first level: the retrieval of data from the objects. Since the recorded data constitute the basis for every analysis, the retrieval of these data should be carried out with the greatest care and in full knowledge of the consequences for further classification and analysis.

The basics of recording

The following questions should be answered before starting the actual recording: which objects should be recorded; which aspects should be recorded; what is the best method of recording.

a) Which objects should be recorded?

Suppose one is to record the basketry housed in a particular museum or found at a certain archaeological site. The decision as to which objects should be recorded depends firstly on the research question. Secondly, depending on the relationship between quantity on the one hand and time and resources on the other, a choice can be made either to record certain aspects, or to record only part of the collection. When there is an explicit research objective, the selection of aspects will be narrowly determined, and the recording of the entire collection will proceed for this restricted set of characteristics only. In some cases, however, the recording has to be carried out without one specific purpose of analysis. This can be necessary when recording a collection which is not easily accessible. Limited

time and resources may force the researcher to obtain a full record on a clearly defined sub-collection. The choice to do a full recording on only part of the collection leads to another problem: which part of the collection should be recorded? The result of the ensuing analysis will be affected by the selection process. It will make quite a difference whether all of the complete objects of an entire excavation are recorded, or all the objects, including all fragments, of a small part of that excavation. The objects selected for recording constitute a sample of the entire collection. Sampling affects the analysis, and is in fact part of the analysis, since the proper sampling of an artefact group should be executed with a certain purpose in mind (Mueller 1979:37).

b) Which aspects should be recorded?

Aspects which can be recorded are: size, shape, technique, special features, material, context and condition. Since analysis is based on a specific question, recording can be limited to the specific aspects which contribute information to that particular question. The choice to do so or not should not only be determined by the time and resources available, but also by the accessibility of the objects involved. When recording an easily accessible collection of basketry which is not threatened by rapid deterioration, it can be useful to limit the recording to some specific aspects. In the field, however, the situation is often different, either because the material is in a bad condition, or because the material will no longer be accessible after being recorded on site. In these cases it might be decided to gather information for a large number of different research questions.

c) What is the best method of recording?

The most important concept in this context is consistency. Recorded data are absolutely worthless if they are not consistent in two ways. Firstly, the same aspects should be recorded for all artefacts. Gaps in a database make it impossible to carry out a proper analysis, and render all recording devoid of any value. Secondly, the manner of recording should be consistent. This is especially important when dealing with 'objective' data such as measurements. When not retrieved wholly consistently, such data are more confusing than revealing. This is even worse than gaps in a database, because biased information is entangled with the data and cannot be identified nor removed.

Consistency in recorded aspects is best achieved by using recording sheets. The framework of the sheet forces the researcher to look at all relevant aspects. Examples of such sheets can be found in the appendix and will be referred to later in this chapter. Secondly, consistency in the method of recording, certainly

when performed by more than one person, can only be achieved by intensive communication. This communication is of the utmost importance, not only when several people are working on one specific group of material, but also when several collections, recorded by different people, are to be compared.

Recording sheets

This book includes three types of recording sheets. They represent three different selections of material: cordage, basketry (including mats) and miscellaneous objects. This division has been made mainly because the shaping of the objects requires specific technical solutions. The cordage technique is marked by the making of long cylindrical strands and the knotting of those strands into objects such as nets. Basketry techniques involve the shaping into containers, which is an integral part of the production process. Mats, which show many similarities to the structure of baskets, are included in this group, although they often consist partly of rope. The "miscellaneous objects" sheet is the escape route for the recording of those objects which cannot be properly described on the basketry sheet. The recording sheet is very similar to the basketry sheet, but offers more liberty in the description. Artefacts such as brushes can be recorded on this type of sheet. The recording sheets are thus an invitation for consistency and on the other hand offer sufficient flexibility in individual cases.

The recording sheets for basketry and miscellaneous artefacts take up at least two pages each. Page 1 deals with the recording of the *identificatory data, technique, size and shape* of the objects. Page 2 records the *special features, material, condition, treatment, storage, use, context*, and offers some space for additional remarks. Adding more pages is optional. A page can be added for drawings or detailed descriptions. The recording sheets for cordage are much more compact: two sheets fit one page. Again extra sheets can be added.

Appendix A contains a number of completed recording sheets for different objects.

Photography or drawing?

The choice between making photographs or drawings is based on economical and technical arguments. Drawing is cheap, but time-consuming. Photography is quick, but more expensive. The most important aspect, however, is the question as to what exactly needs to be shown. A general impression of the artefact is best given by a photograph. Technical details, to the contrary, are generally lost in a photograph. They are best recorded by technical drawings. Such drawings are not made

to scale, since the structure has to be expanded in order to clarify the technique. Similarly a drawing of the shape can show more than a photograph, by presenting a reconstruction of the original shape, rather than recording the present shape. In the case of drawings of the shape it is imperative to make a drawing to scale.²

1. Identification

The top part of each recording sheet has been designed to give background information about the recorded object (see Figure 4). This feature helps to identify specific objects. The identification section is identical for all three types of recording sheets.³

ID number: The first objective of the recording process is to make certain that all data can be linked back to the relevant objects. That is why every single object is given an individual number. This number is put on the label which is linked to the object, on the recording sheet and on photographs or drawings of the specific object.

| Basketry Recording Sheet | | page 1 | |
|--------------------------|-------------|---|-----------------------------------|
| 1 IDENTIFICATION | | photo archive | ID number: <input type="text"/> 1 |
| site/museum: | number: | black&white: | |
| date: | researcher: | slides: | description: |
| | | complete/greater part/fragment/other way of preservation: | |

Figure 4. The part of the recording sheet on which the identificatory aspects of each object are recorded.

² A second argument is the technical ability of the photographer and/or draughtsman. Proper preparation is important in both cases. Literature is available on object photography (e.g. Conlon 1973; Simmons 1969). Many different styles are used for drawing objects. The only rule which is generally applied in archaeological drawings, is that the shadows are drawn as if the light comes in from the top left of the object.

³ True scientific work is open for examination. Either verification or falsification of data starts with the possibility of checking the reliability of work done before. This is only possible if references to specific objects are available. Therefore, this section for identification is of utmost importance.

Description: A brief description in which the most striking features of the object are listed, is meant as a mnemonic short-cut to the information given below. The description is for identifying purposes only and consistency in terminology is not imperative. A description such as "large blue basket", referring to size and decorative aspects or "coiled bread basket", referring to technique and function can be used alongside each other. The description has no analytic or classificatory value.

Complete/greater part/fragment/other way of preservation: The state of preservation, and with it the data which can be derived from the object, are roughly indicated by circling one of the four options. The options are:

- The object is complete (all aspects can be recorded);
- The object is not complete, but the fragment(s) make(s) out the greater part of the object (the size and shape are still distinguishable, all aspects can be recorded);
- Just a fragment or a number of fragments are left, which do not indicate the size and shape of the original object, but give information on technique and material;
- Not (part of) the object itself is preserved, but the size and technique can still be recorded from a different way of preservation, such as impressions, carbonization or fossilization.

Site/museum: This is the place to indicate the location where the object was found/studied.

Number: In this box all numbers previously given to an object are noted down, together with the organization which provided the number. Thus the recording of museum material can be cross-referenced with the museum catalogue, and archaeological material can be traced in the archaeological records.

Date: Here the researcher indicates the date of inspection of the object.

Researcher: Who did what and when. The person who has recorded the basketry can thus be traced, if necessary, for further information.

Photo archive:

Black & white / slides:

All photographs (usually black & white or colour slides) of the object should be listed. This entry facilitates the tracing down of the photographic recording of the objects. Thus basketry photographs incorporated in a site or museum photo-archive can be located as quickly as those included in a separate basketry archive. If other types of audio-visual recording, such as colour prints, video or film, have

been made, this has to be noted down as well, for instance under *12 REMARKS*, with a reference in the 'photo-archive' box.

2. *Technique*

2.1. *Cordage* (see Figure 5)

The possibilities to make long cylindrical strands are divided into three categories: sP[C]; plait; other.

sP[C]:

This formula points at the various techniques of twisting fibres into long strands. The twisting is done by spinning the fibres into strands and plying and cabling

| | | | |
|-----------------------------|-----------|-----|------------------------------|
| 2 | TECHNIQUE | [] | overhand knots S-orientation |
| sP[C]: | | [] | overhand knots Z-orientation |
| plait: | | [] | half knots S-orientation |
| other: | | [] | half knots Z-orientation |
| Cl _s -----x100 = | | [] | reef knots SZ-orientation |
| Cl _p -----x100 = | | [] | reef knots ZS-orientation |
| Cl _c -----x100 = | | [] | granny knots SS |
| | | [] | granny knots ZZ |
| PI: | | [] | mesh knots S-orientation |
| | | [] | mesh knots Z-orientation |
| | | [] | other knots |
| description/drawing: | | | |
| | | | see page ... |

Figure 5. The part of the recording sheet on which the technique of cordage is recorded.

several strands together. The direction of spin, ply and cable can vary, as illustrated in Figure 6. The middle stroke of the letters S, Z and I indicate the direction of either spin, ply or cable.

The twisting of several fibres to form a yarn is called spinning. Unspun fibres are symbolized by the letter i. Spun yarns can either be spun in an s-direction or a z-direction. The direction of spin is symbolized by a small letter s or z, the middle stroke of the letter indicating the direction of the spinning.

Several spun yarns can be plied to form a string. As in the case of spinning, plying can be done in an S, Z or I direction. The direction of ply is marked by a

capital letter S, Z or I.⁴ The subscript number next to the capital letter indicates the number of elements that make up the string: the number of yarns that are plied. Usually two or three yarns are used to form a string.

Several plied strings can be cabled together to form a stronger type of rope, in this book referred to as 'cable'. The direction of cabling can be S or Z and is indicated by a capital letter [S] or [Z] in square brackets. A subscript number at

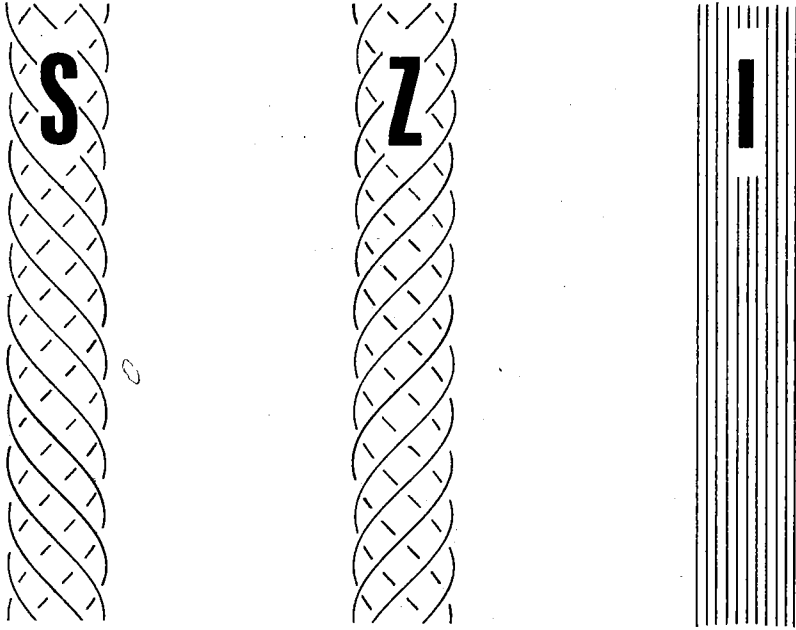

Figure 6. "S", "Z" and "I" direction in which cordage can be spun, plied or cabled.

⁴ I-ply string stands for two or three parallel yarns. Of course 'parallel' and 'plied' are contradictory. The indication 'I-ply' is used to record the direction of ply when it is not clear if the direction is S or Z. This, for instance, can occur in tightly cabled ropes when the force of the cabling dislocates the ply.

the right hand side indicates the number of strings which make up the cable. This number is usually two or three.

example: (see figure 7)

A yarn (a) made of fibres which have been spun in a Z-direction is symbolized by a small letter z. A string (b) which has been plied in a S-direction, is symbolized by a capital letter S. The subscript 2 indicates that the string is made up of two yarns. A cable (c) which has been cabled in a Z-direction, is symbolized by a capital letter Z in square brackets. This [Z] is followed by an indication in subscript of the number of strings that are involved in the cabling (in this example three). The rope of figure 7 is thus recorded as $zS_2[Z]_3$.

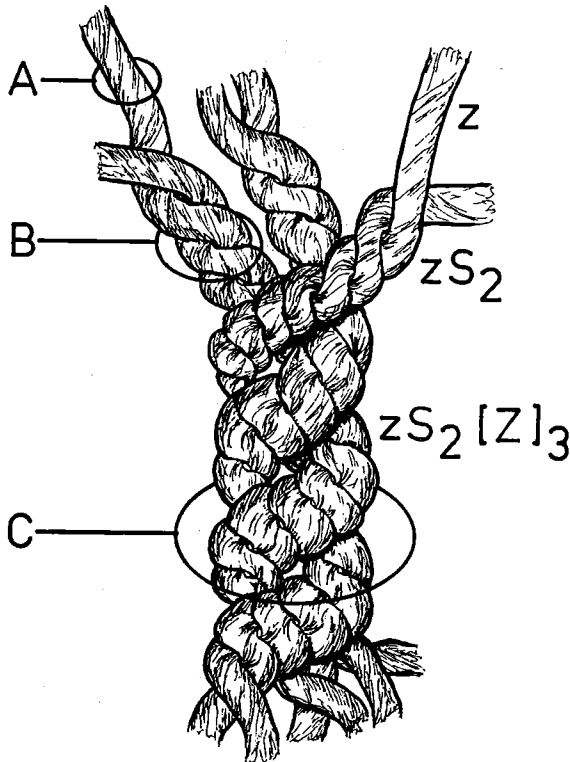

Figure 7. z - spinning, S - plying, Z - cabling ($zS_2[Z]_3$ rope).

plait:

Plaiting is the interlacing of three or more strands. The variety in plaiting is enormous. A plait can be used to create either a flat surface, a ribbon shape or a cylindrical strand. In the latter case, plaits are considered as cordage. Figure 8 shows a plait made out of three strands, Figure 9 shows a plait which is made with eight strands. The eight strands have been plaited around a core. More will be said about plaiting in relation to basketry in section 2.2 (see pages 59-68).

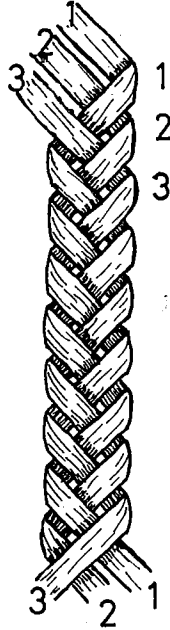

Figure 8. A plait with three strands.

other:

Other methods of making strands often make use of already spun yarns or spun and plied strings. Examples are spool knitting (Figure 10), which is the interlacing of one string and continuous knotting which can be done in many different ways by using one or more strands. Figure 11 shows an example of a continuously knotted rope. The technique, crowning in alternate directions, is one of many to make sinnets (Ashley 1947:479 #2915).

CIp and CIc:

Part of the recording of plying and cabling consists of determining the Cord Index of Ply (CIp) and the Cord Index of Cable (CIc). If we look at Plate 1 it becomes clear that there is a large variety of techniques and tightness (or *speed*) of the ply

and cable. The objective of the two indices is to determine how tight the strings have been plied and cabled. The tightness is one of the factors that determine the flexibility of the string. Other factors are the material chosen and the diameter of the strands.⁵ The tightness is also one of the factors that determines the strength or tractive power of a rope.⁶

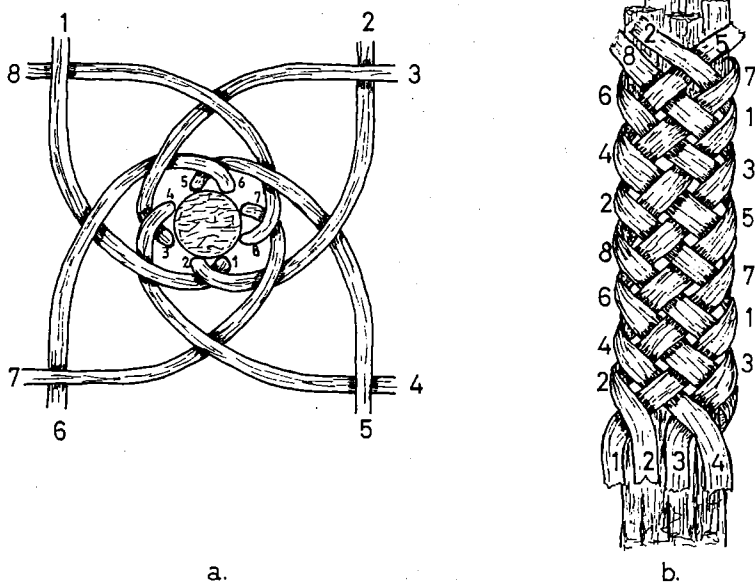

Figure 9. A plait with eight strands around a core. a. cross section; b. appearance.

⁵ In order to determine the flexibility of a rope an index should be made which indicates the length of string needed to form the smallest loop that rope can make, given a certain amount of pressure (see Figure 12). Since complex laboratory facilities are needed to test flexibility (the amount of pressure has to be standardized), it is not possible to be more precise in the field than by stating that a rope is "more flexible" or "less flexible" than expected from the Cord Index and the diameter. The difference in flexibility is usually caused by a combination of differentiation in raw material, size and tightness of spin, ply and cable.

⁶ As for the flexibility, the determination of working load, or breaking strength (tensile strength) of rope is also dependent on controlable circumstances, which can only be attained in a well equipped laboratory (Maclean 1982:162-169). The testing of the strength at which a rope breaks, by hanging an increasing weight from it is of course destructive for the tested specimen. This means that such tests are not suitable for unique ethnographical material. For archaeological cordage an additional problem occurs. The tests have to be done with reconstructions of the ancient rope, in order to test the original working load. Experiments such as these are extremely complicated, since they not only involve scientific testing facilities, but also the mastering of ancient technology.

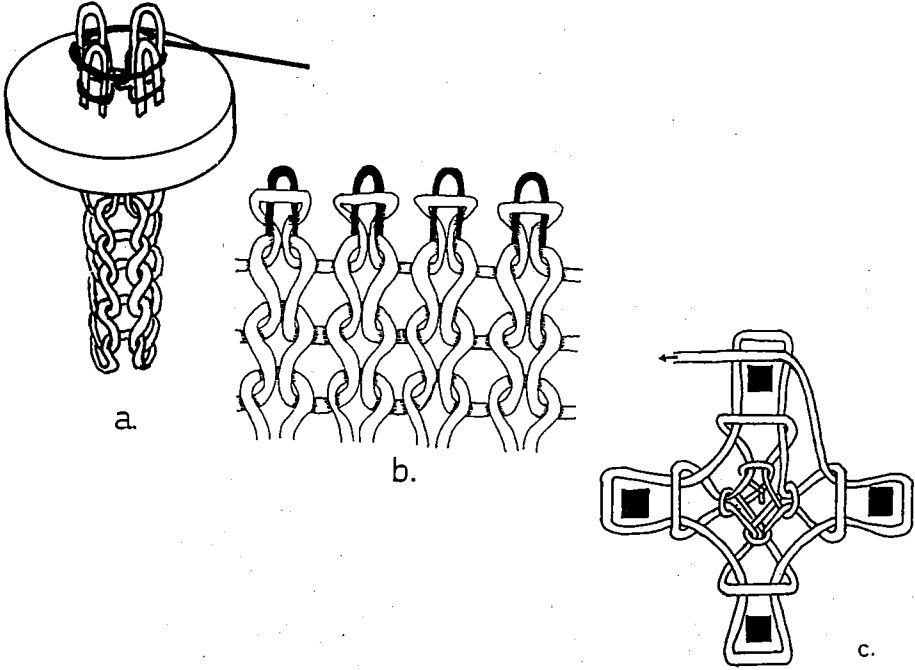

Figure 10. Spool knitting. a. appearance; b. structure; c. technique and start.

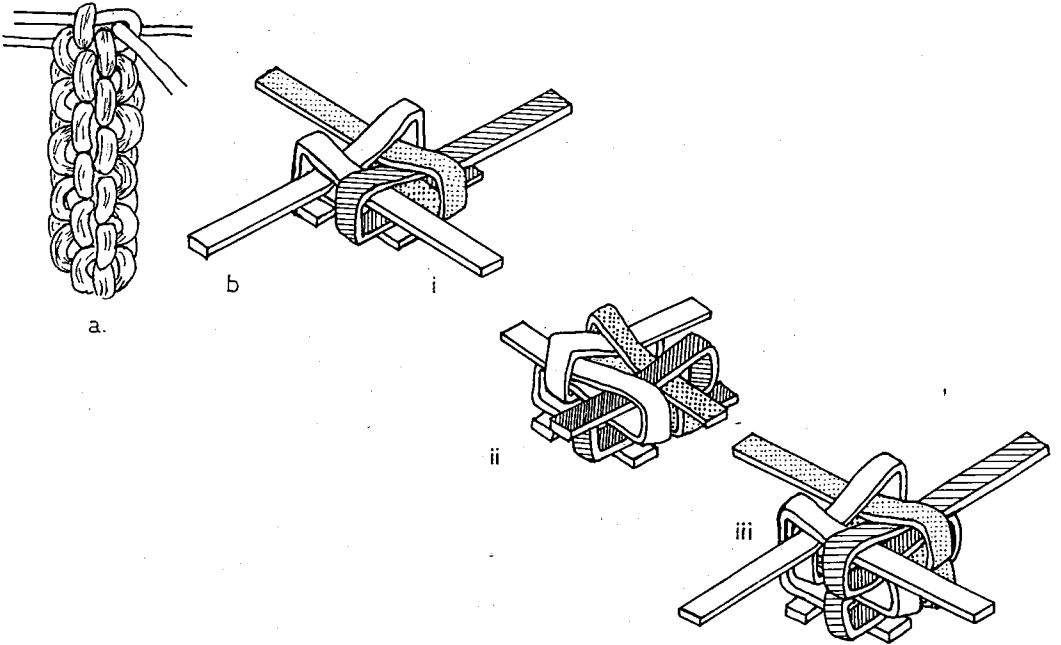

Figure 11. Four crowned sinnet in alternate directions. a. appearance; b i-iii. different stages.

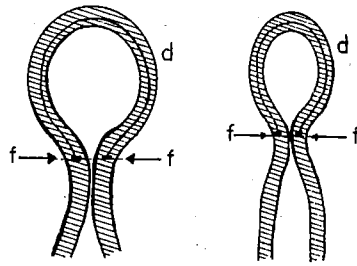

Figure 12. Theoretical means of determining flexibility: a constant amount of force (f) presses the rope together. The distance (d) between the points where the rope meets gives an indication of the flexibility. Of course the diameter of the rope has to be taken into account.

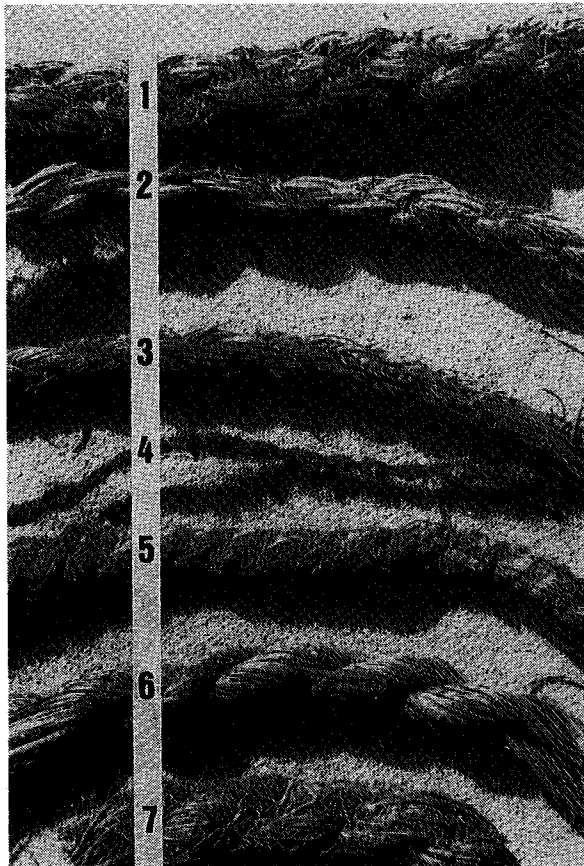

Plate 1. Variety in cordage: 1 = $zS_2[Z]_3$, 2 = $zS_2[Z]_2$, 3 = sZ_3 , 4 = sZ_2 , 5 = zS_3 , 6 = zS_2 , 7 = zS_2 . All strings have been excavated by the expedition of the university of Delaware. All material originates from the Roman ford at Abu Sha'ar (Egypt) and dates from the 3rd to 4th century A.D.

Since both flexibility and strength cannot be expressed precisely, unless a specific laboratory arrangement is made, the recording sheet has no entry for these aspects. The indices are determined as follows:

Cord Index of Ply: A number of turns, made by the plying of two or more yarns, are counted (n in Figure 13). This number n is multiplied by the average diameter of the yarns (d). This result is divided by the length over which the n number of turns extends (l).

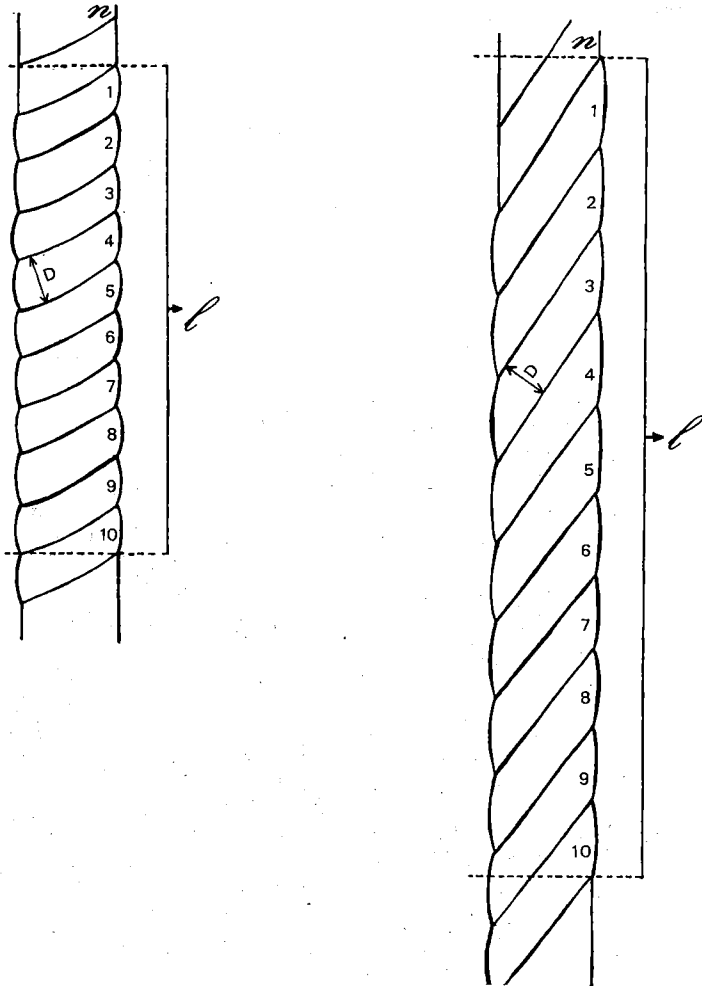

Figure 13. Determining the Cord Index: $CI = \frac{n \times d}{l}$

Cord Index of Cable: As in the case of the Cord Index of Ply, a number of turns, made by the cabling of two or more strings, are counted. This number n is multiplied by the average diameter of the strings (d) and the result is divided by the length over which the n number of turns extends (l).

In theory the same procedure could be followed for a Cord Index of Spin, in which n is the number of turns of the spun fibres, d is the diameter of the fibres and l is the length over which the chosen number of turns extends. In practice this presents some difficulties, since the fibres are often too small or too irregular to give a reliable result. In short the formula is $\frac{n \times d}{l}$.

l

The result, a number between 0 and 1, is multiplied by 100. The higher the number, the tighter the ply or cable. The determination of the Cord Index is

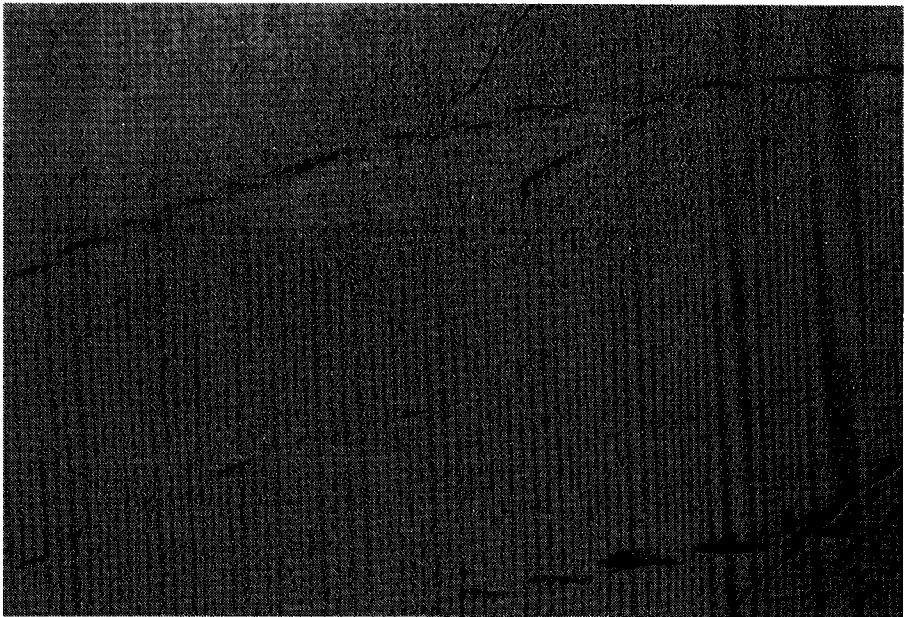

Plate 2. String impressions of zS_2 string on an amphora, found by the expedition of the Egypt Exploration Society in Tell el-'Amarna (Egypt). The amphora stems from the New Kingdom period (1350 B.C.).

independent from the number of yarns with which a string is plied or the number of strings with which a rope is cabled.⁷ It is important to indicate whether the spinning, plying and cabling is regular or irregular in appearance.

String impressions on pots give information on technique, directions of spin and ply, and may even help to calculate a cord index (see also Hurley 1979). Plate 2 is an example of string impressions on an amphora from 1350 B.C. (Tell el Amarna, Egypt).

PI:

The Plait Index follows the same method as the cord index and is meant to determine the angle of plait. Directions on how to measure and calculate the Plait Index can be found below (see pages 66-68).

knots:

Those knots which occur most frequently are incorporated in the recording sheet and only need to be counted.

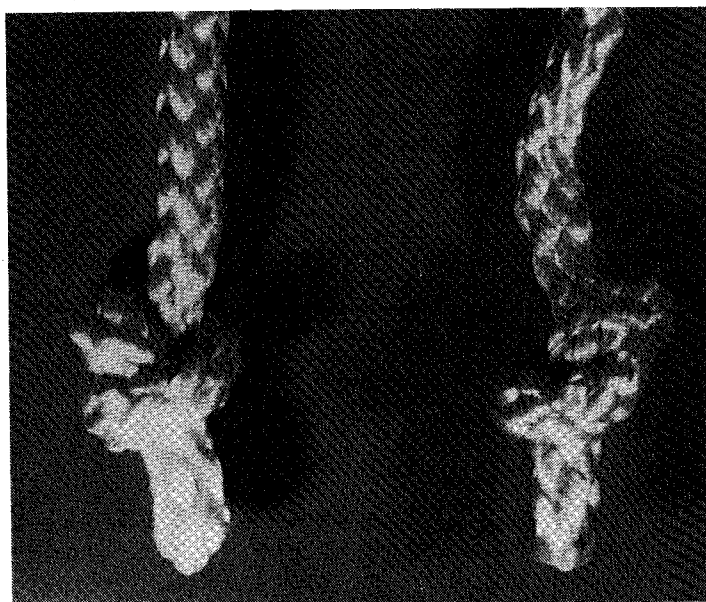

Plate 3. Overhand knot S-orientation (left) and overhand knot Z-orientation (right).

⁷ The Cord Index has a value ranging from 0 to 100. In the case of the plying of two yarns, a CIP of 0 indicates that the yarns are run parallel; a CIP of 100 indicates that the yarns lie at a right angle. The average value of the CIP lies between 30 and 50.

overhand knot / half knot (S- and Z-orientation):

The knot illustrated in Figure 14 is indicated by many different names. The difference in terminology is partly due to a difference in function. This knot when used at the end of a string is called an *overhand knot* (see Plate 3). The overhand knot is a stopper knot, used either to prevent a string from unravelling, or to thicken the end of a string to prevent another knot (for instance a bow knot) from

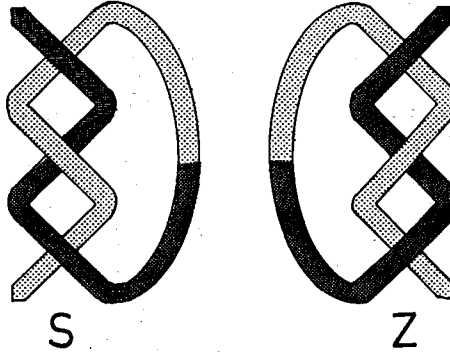

Figure 14. The overhand knot or half knot in S and Z orientation.

loosening. When the same knot occurs in the middle of a string, and is used as a binding, rather than a stopper knot, it is called an *half knot* (see Plate 4).

As with rope, all knots which are not mirror images, according to reflection geometry, occur in two orientations. These orientations are expressed as S- and Z-orientation, according to the middle stroke of the letter S and Z which feature as the main direction of the knot.

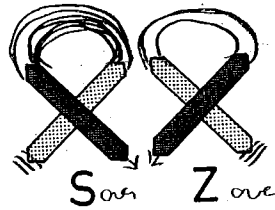

Figure 15. S and Z crossing.

S under S over
Z under Z over

Figure 15 illustrates that even a simple crossing of two strands can occur in two directions. Figure 16 shows these two directions for a string which has been plied out of two yarns. The same principle applies for the *overhand knot* and the *half knot*. Figure 14 illustrates the knot in S and Z orientation: the part in the middle that crosses over follows the middle stroke of either the letter S or the letter Z.

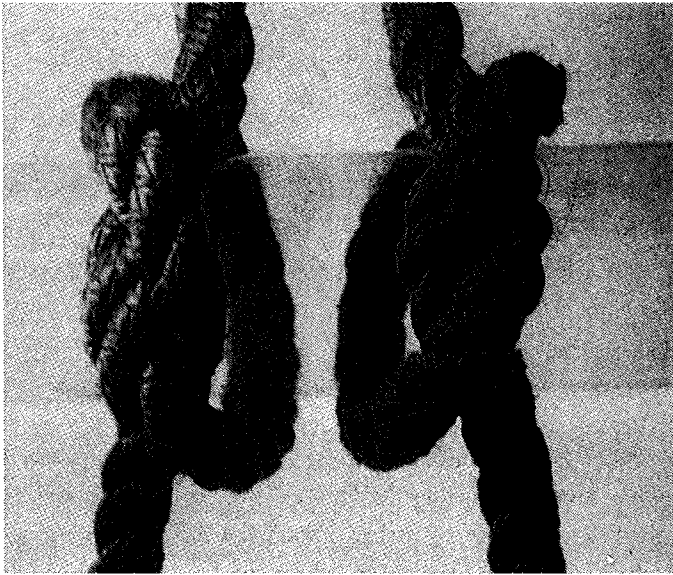

Plate 4. Half knot S-orientation (left) and half knot Z-orientation (right).

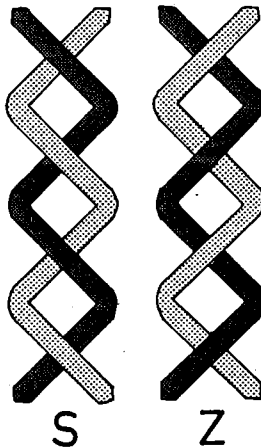

Figure 16. When S and Z crossing is repeated we have the principle of a two-ply string in S or Z orientation.

reef knot (SZ and ZS-orientation)

A similar difference in orientation can be spotted in the *reef knot*, which in fact consists of two half knots knotted in opposite direction (SZ or ZS, see figure 17). There is a difference in torsion between a reef knot which consists of an S-half knot plus a Z-half knot and a reef knot in which first the Z- and than the S-half knot has been tied (see plate 5).

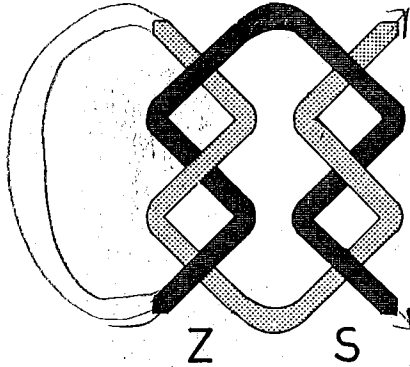

Figure 17. The reef knot.

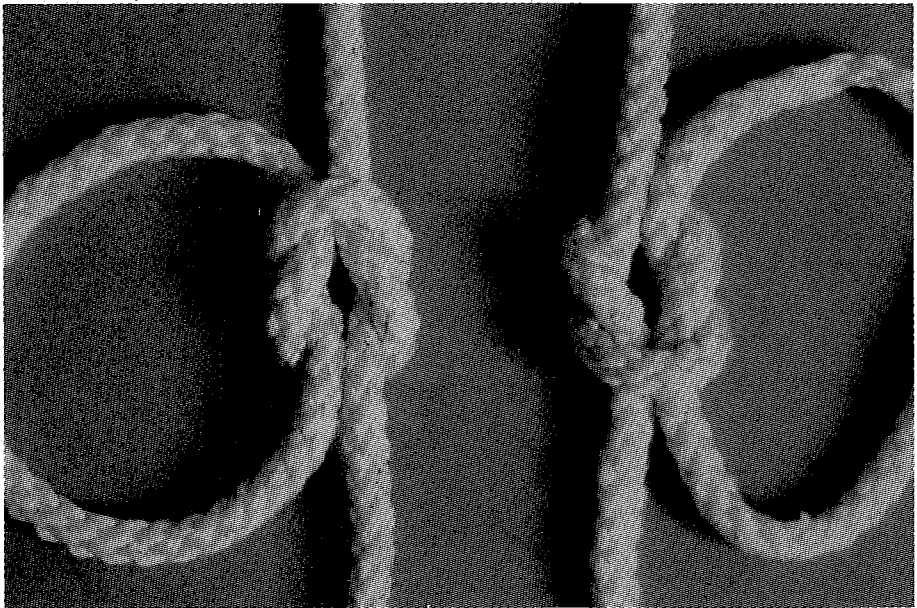

Plate 5. The reef knot in two orientations; consisting of a Z-half knot followed by an S-half knot (ZS to the left), respectively an S-half knot followed by Z-half knot (SZ to the right).

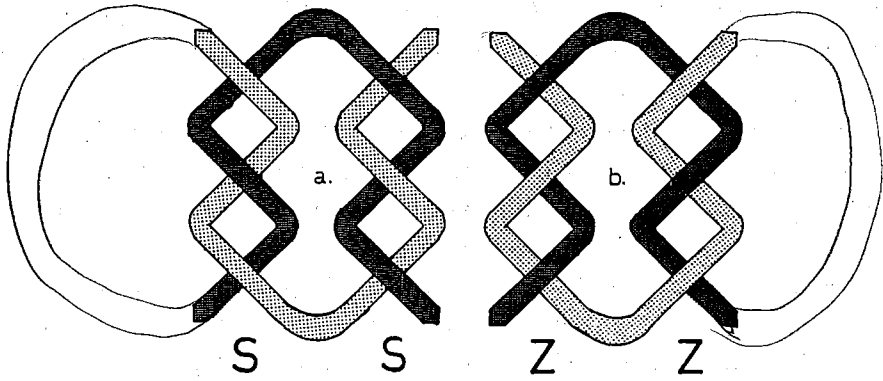

Figure 18. The granny knot. a. consisting of two S-half knots; b. consisting of two Z-half knots.

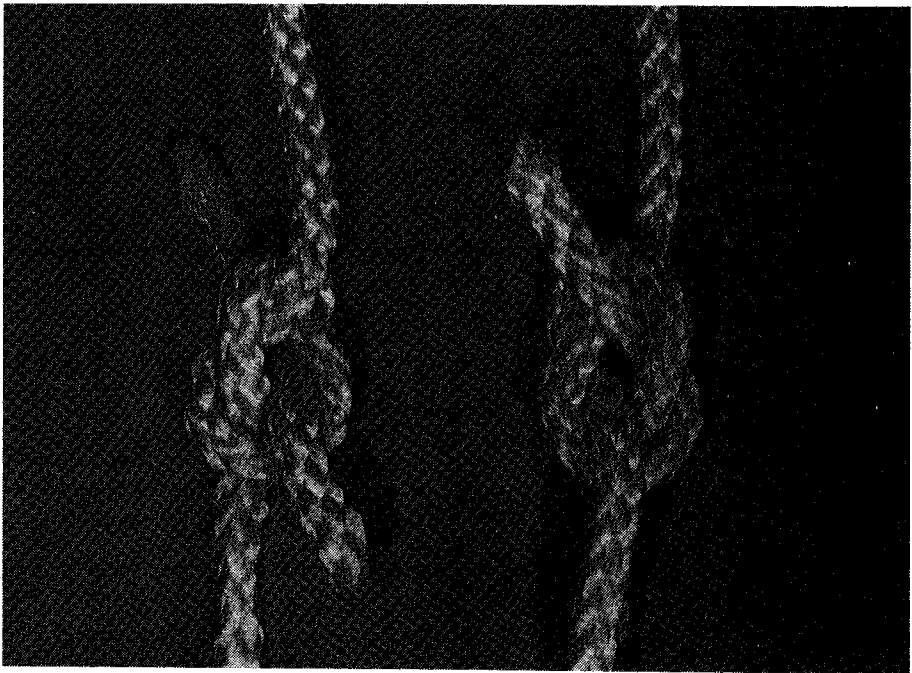

Plate 6. The granny knot: SS-orientation (left) and ZZ-orientation (right).

granny knot (SS- and ZZ-orientation)

When the two half knots are knotted in the same direction (SS or ZZ), the result is a *granny knot* (Figures 18a and b; Plate 6).

mesh knot (S- and Z-orientation):

The *mesh knot* is the knot which is generally used for making nets. This knot occurs in two orientations (Figures 19a and b). In order to understand the different production processes of netting, the orientation of the knots contains important information. Knotted netting can be made in many ways, but two varieties occur generally in different periods and different areas. Firstly, the net is worked from left to right with only mesh knots in Z-direction. At the edge of the net, the work is turned around, or the net maker changes position and works on the other side of the net, again from left to right with Z mesh knots (Figure 20). Secondly, the work is not turned around. The net maker is working one row from left to right with Z mesh knots and the next row from right to left with S mesh knots (see Figure 21). Knotted nets are usually made with a netting needle (Ashley 1960:64).

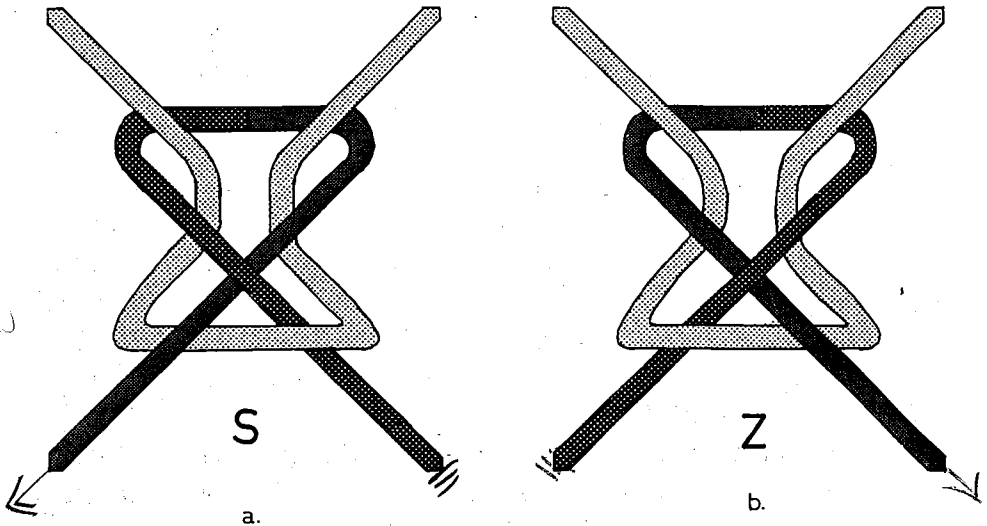

Figure 19. The mesh knot. a. S-direction; b. Z-direction.

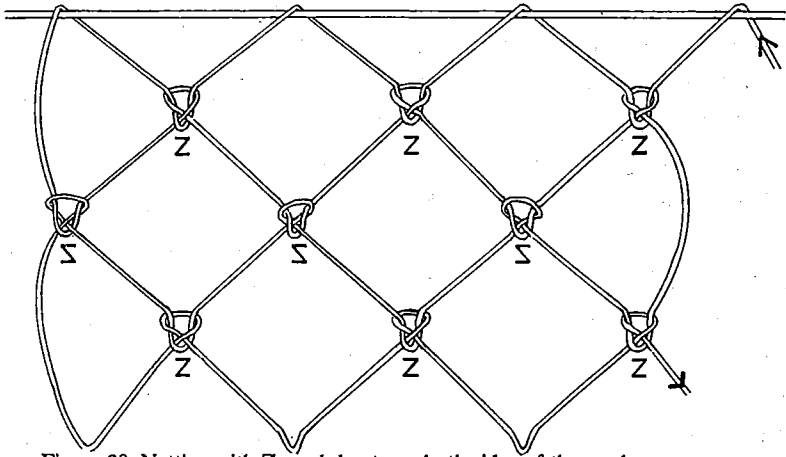

Figure 20. Netting with Z-mesh knots on both sides of the work.

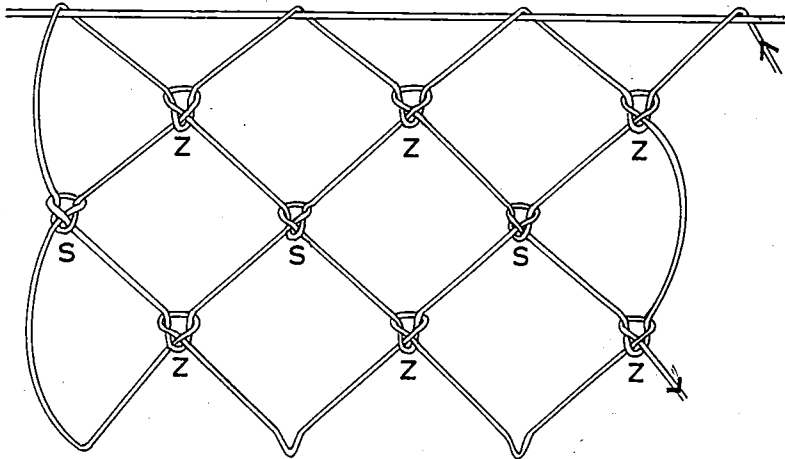

Figure 21. Netting with alternate Z-mesh knots and S-mesh knots on one side of the work.

Netting can also be made with many other knots, such as reef knots (Figure 22a and b) or *overhand bends* (Figure 23). Netting is often done by looping without the use of knots. Figure 24 is an example of a netting technique, often regarded as knotless netting.⁸ It is also possible to indicate this technique as "netting with S-half knots".

All knots except for the ones mentioned above, should be drawn schematically (not to scale), in order to illustrate their exact structure, which tells more

⁸ Also indicated as *linking* (Emery 1980:30)

than their outer appearance. The variety of knots is enormous. Although literature on modern knots is useful as a comparison, giving data on the construction and use of knots (e.g. Ashley 1947; Graumont 1939), it is best to start drawing the knot without having a specific knot in mind. In this way alternative knot constructions or 'mistakes' are not missed out.

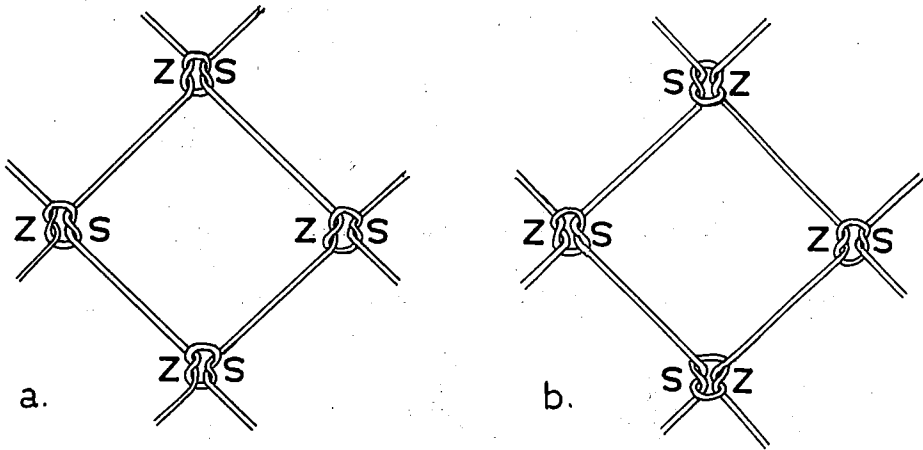

Figure 22. Netting with reef knots. a. all knots with the same orientation (ZS); b. rows of alternate orientated knots (ZS / SZ).

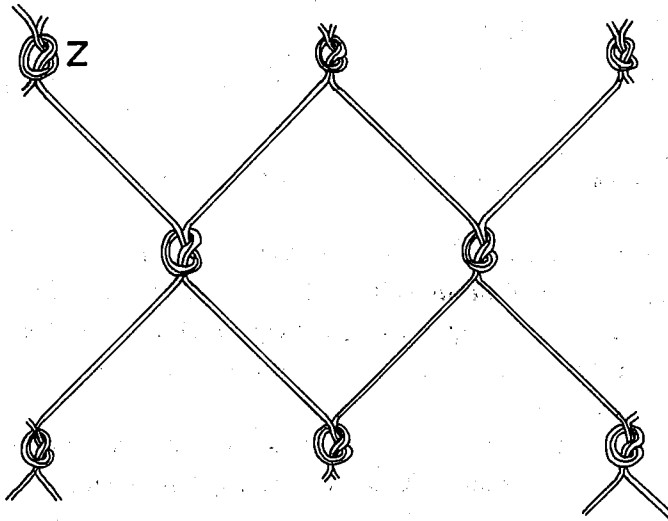

Figure 23. Netting with double overhand knots (overhand knots made in two parallel strings).

The recording of archaeological knots often presents difficulties, especially when the knots are deteriorated or incomplete. When analysing modern knots it is possible to pull parts and bights in order to determine the construction of the knot. Archaeological material cannot be treated this way. Therefore, ancient knots have to be reconstructed by drawing the construction after careful probing with surgical needles. The use of coloured string to make a reconstruction of the knots, is indispensable to test the drawings on validity or feasibility.

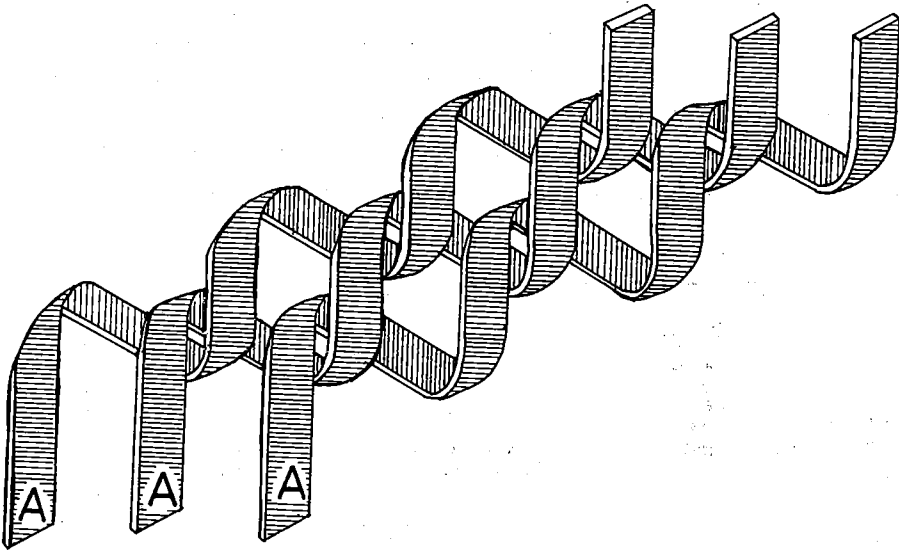

Figure 24. Netting with S-half knots (= Figure 30).

2.2 Basketry and Mats

The large number of basketry techniques is easily distinguishable, even to the untrained eye. It is important, however, to determine which details are different, and which aspects of apparently different baskets in fact are identical. Such similarities are often not obvious. Details such as working up the raw material in the same direction, or similarities in fastening off the material, even when the basic technique differs, may point at a correspondence of basketry manufacture. In order to decide on the exact differences and similarities it is important to record uniform data for all objects. If a division is made at an early stage in main groups of basketry techniques, such as 'twined', 'coiled', or 'plaited', which are then all recorded in a different way, the ensuing comparison of the different techniques is made extremely difficult.

Four stages are involved in describing the technique: the basic structure; the beginning and end of the strands; the construction of the shape, and the effect of the raw material. The basic structure is the way in which the strands form a coherent fabric. The structural elements and the way they interact thus form the first part of the recording of the technique (BASIC STRUCTURE, SIDE). Secondly the start and fastening off of these structural elements is recorded (BASE, RIM). Thirdly, the method used to construct and maintain the shape of the object is studied (TRANSITION BASE-SIDE, METHOD OF SHAPING). The fourth step is to look at the specific properties of the raw material. Because the raw material often is minimally prepared, the original shape in many cases is still recognizable. The limited length of the strands and the specific shape tend to affect the applied technique (SIDE, OTHER).⁹ The technique is described in the recording sheet in six blocks in which these four aspects are incorporated.

2.2.1 Basic structure (Figure 25)

| | | | | | |
|---|--|---|--|--|--|
| <p>2 TECHNIQUE</p> <p>BASIC STRUCTURE</p> <p>no. of systems []</p> <p>System 1</p> <p>one element/set of elements</p> <p>active/passive</p> <p>no. of members [] S/Z/I</p> <p>preparatory work:</p> <p>none [] corded [] plaited []</p> <p>other:</p> <p>System 2</p> <p>one element/set of elements</p> <p>active/passive</p> <p>no. of members [] S/Z/I</p> <p>preparatory work:</p> <p>none [] corded [] plaited []</p> <p>other:</p> <p>System 3</p> <p>one element/set of elements</p> <p>active/passive</p> <p>no. of members [] S/Z/I</p> <p>preparatory work:</p> <p>none [] corded [] plaited []</p> <p>other:</p> | | <p>BASE scheme of centre</p> <p>plaited: system no. []</p> <p>no. of strands []</p> <p>under /over /shift</p> <p>PI:</p> <p>angle of plait:</p> <p>reg/irr.</p> <p>corded: system no. []</p> <p>sP(C):</p> <p>Cl_g ——— x100 =</p> <p>Cl_p ——— x100 =</p> <p>Cl_r ——— x100 =</p> <p>reg/irr.</p> <p>facing system: no. []</p> <p>rigid []</p> <p>flexible []</p> <p>semi-flexible []</p> <p>see page ...</p> | | <p>SIDE scheme basic structure</p> <p>orientation inside/e/ reversed e</p> <p>active system () passive system ()</p> <p>no. of elements: no. of elements:</p> <p>no. of rows: no. of rows:</p> <p>Other systems (specify):</p> <p>Insertion/exhaustion:</p> <p>see page ...</p> | |
| <p>TRANSITION BASE-SIDE METHOD OF SHAPING</p> <p>Description/drawing:</p> | | <p>RIM, EDGE Description/drawing:</p> | <p>OTHER Description/drawing:</p> <p>see page ...</p> | | |

Figure 25. The part of the recording sheet on which the basketry technique is recorded. The unshaded part deals with the basic structure of the basketry technique.

⁹ For a discussion of the effect of raw material on basketry techniques, especially in comparison with textile techniques, see Wendrich 1990, 1991.

No. of systems:

The central concept in determining the basic structure of a technique is *system*. This term is used specifically for a group of elements which are all made of the same material and which have the same orientation and function in effecting coherency in a basketry object. In order to determine how many systems are involved in a technique we have to decide which elements belong to one system and which to another.

Figure 26 presents a basketry technique which consists of two systems, *a* and *p*. Each system consists of a number of parallel elements, all of these playing the same role within the technique. In order to determine the number of systems, in this case two, there are three important sets of questions, relating to (A) the raw material which was selected for the elements; (B) the orientation of the elements, and (C) the function of the elements.

A.1. Are all elements made of the same species?

If the answer is negative, for instance if one set of elements is made from willow rods and the other consists of grass leaves, then we are dealing with two different systems, as is the case in our example in Figure 26. If the answer is affirmative, then the next question is asked.

A.2. Are all elements prepared in the same way?

If the answer is 'no', for instance when one set of elements is made of split and the other of unsplit willow rods, we are dealing with two different systems (see Figure 27). If the answer is 'yes', we go on to the next step.

A.3. Is the size and flexibility of the material the same?

If the answer is negative, for instance when one set of elements consists of slightly thicker or tougher willow rods than the other, we are dealing with different systems (see Figure 28). If the answer is still positive, then it is clear that merely on the basis of the raw material it is impossible to decide how many systems are involved. In that case the next step is to look at the orientation of the elements in the structure. From Figures 26-28 it becomes apparent that we have two sets of elements, *a* and *p*, each set consisting of a number of parallel strands. The two sets of elements are set at right angles. The orientation of the two sets of elements clearly is not the same. The question therefore is:

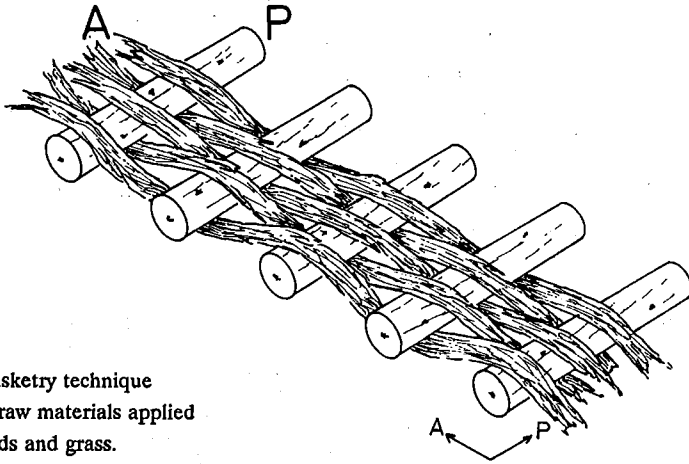

Figure 26. Basketry technique in which the raw materials applied are willow rods and grass.
A = active, P = passive.

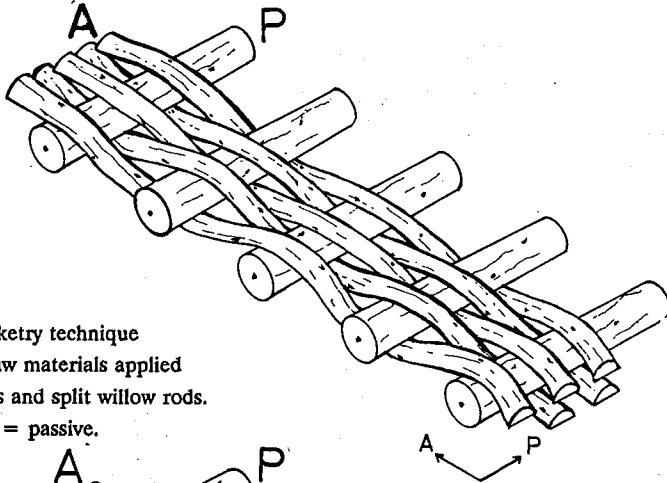

Figure 27. Basketry technique in which the raw materials applied are willow rods and split willow rods.
A = active, P = passive.

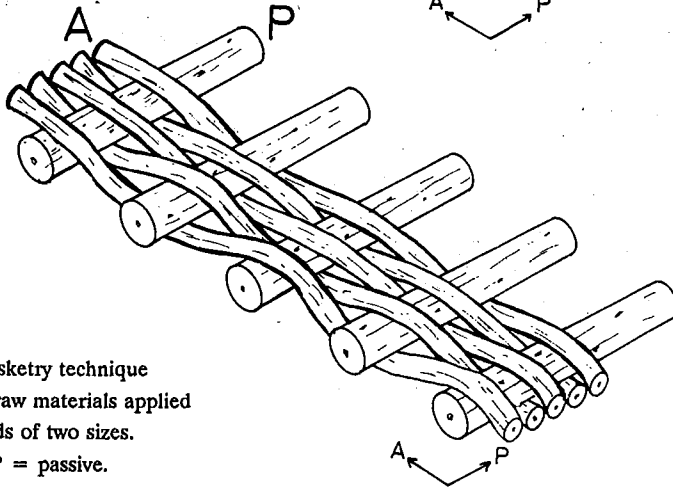

Figure 28. Basketry technique in which the raw materials applied are willow rods of two sizes.
A = active, P = passive.

B. Is the orientation of all the elements the same?

If the answer is negative (as in Figure 26-28), then we are dealing with different systems. If the answer is affirmative (as in Figure 29, where a and p are running in the same direction), we have to decide on the function of the elements in the technique. Looking at Figures 26-29, it is clear that apart from a difference in

Figure 29. Basketry technique in which both systems (A and P) have the same orientation.

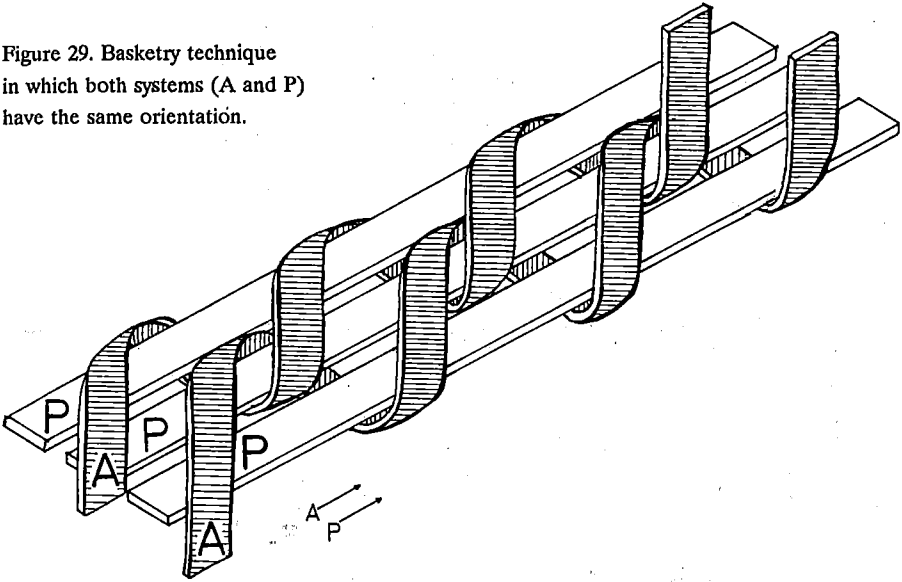
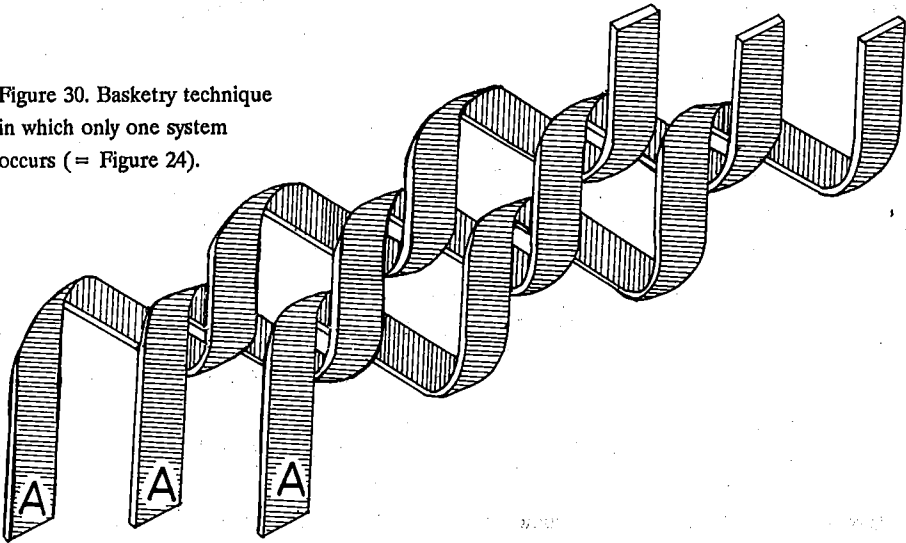

Figure 30. Basketry technique in which only one system occurs (= Figure 24).



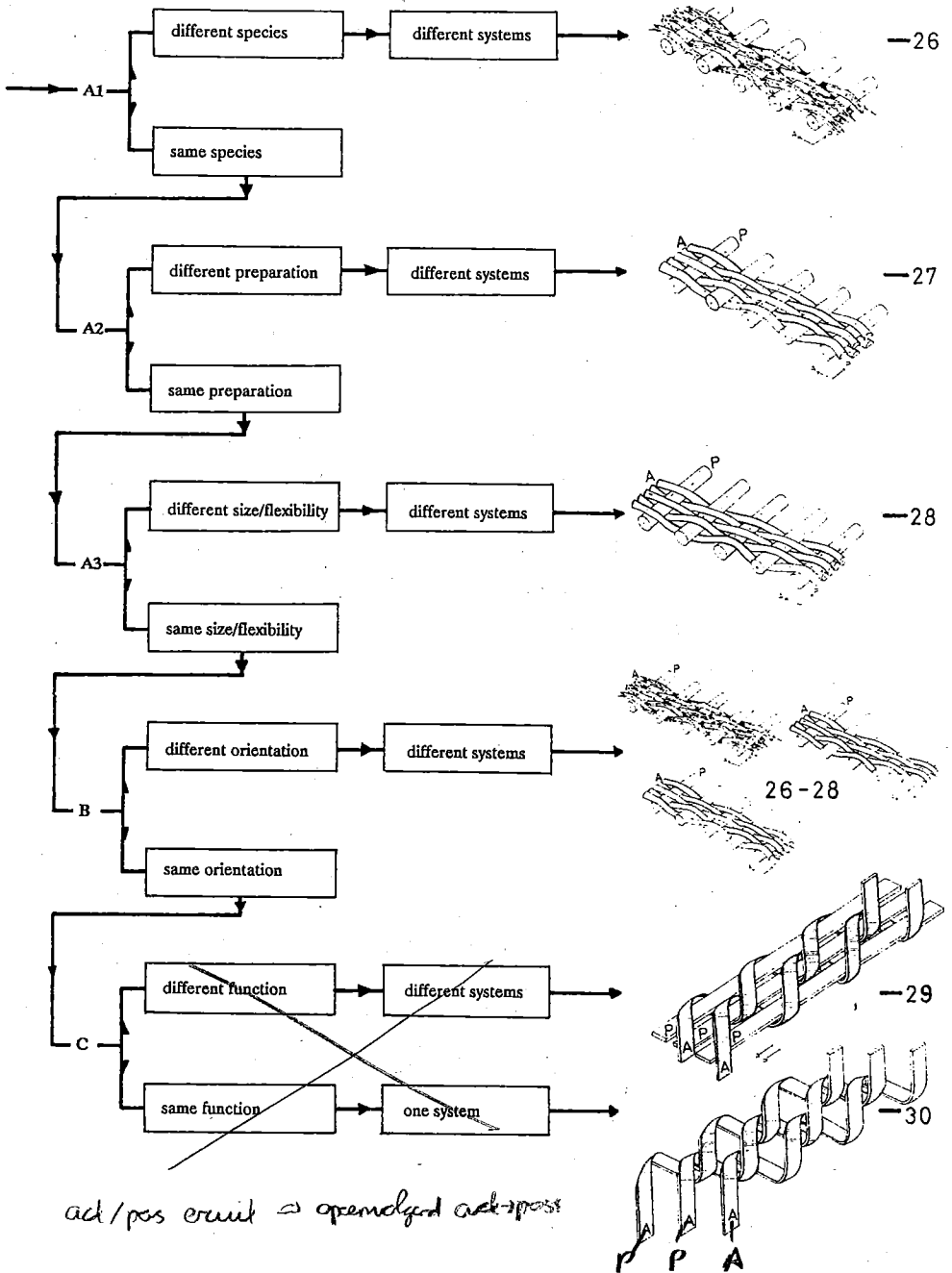

Figure 31. Flow chart for the determination of the number of systems in a basketry technique.

orientation, there is a difference in function as well. System *p* is passive, system *a* is active. Active in this context means that the elements are involved in creating coherency in the structure. Active elements hold together passive elements. They are usually more flexible than passive elements. The passive elements form the body of the technique. The last question therefore is:

C. Is the function of all elements the same?

If the answer is 'no' (as in Figures 26-29) then we are dealing with different systems. If the answer is 'yes' (as in Figure 30), and if the answer to all other question has been affirmative also, then we are dealing with one system only.

Figure 31 presents a flow chart of the different possibilities. To differentiate between systems at least one of these aspects has to be different from the others. Often more than one aspect is different, as in Figure 26 in which three aspects, the material (species), the orientation and the function are different.

A basketry technique consists of at least one system. Most frequently there are two systems, but combinations of three up to six systems also occur. Figure 32 shows a four-system basketry technique. System 1, 2 and 3 are identical if species, preparation or size and flexibility are considered. They are all passive. The only aspect that defines them as three different systems is the variety in orientation.

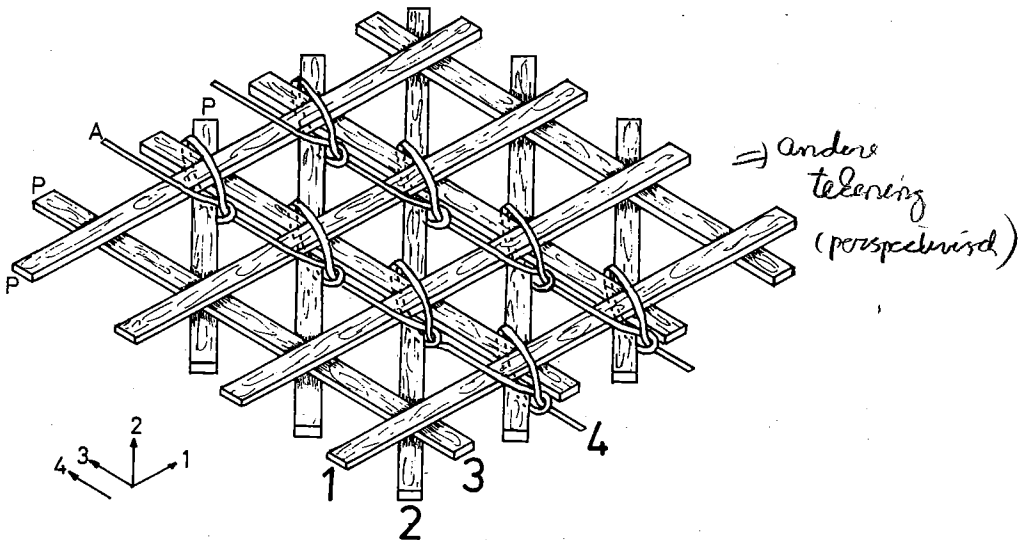

Figure 32. Basketry technique with four systems: system 1, 2 and 3 are passive, system 4 is the active system which ties the three passive systems together and creates the coherency of the basketry technique.

The fourth system has the same orientation as system three, but differs on all other aspects. System four is made of a different material and is the only active system. Figure 32 shows that there would be no coherency without the active system.

System 1, System 2, System 3

Subsequently each system is recorded separately. The sheet offers space to record three different systems. Any other system can be described on the separate recording sheet page 3.

one element / set of elements

By circling one of these options it is indicated whether the system consists of one element or a set of elements. In Figure 29 two systems occur, each of which consists of a set of elements. A set is a number of parallel elements which have the same function in the process of working up. The elements of a set are used at the same time, parallel to each other. Figure 33 shows an example of two systems, both consisting of one element. Element *p* is a strand which is coiled. Element *a* is a long strip which winds itself around the strand, and holds it in place. Of

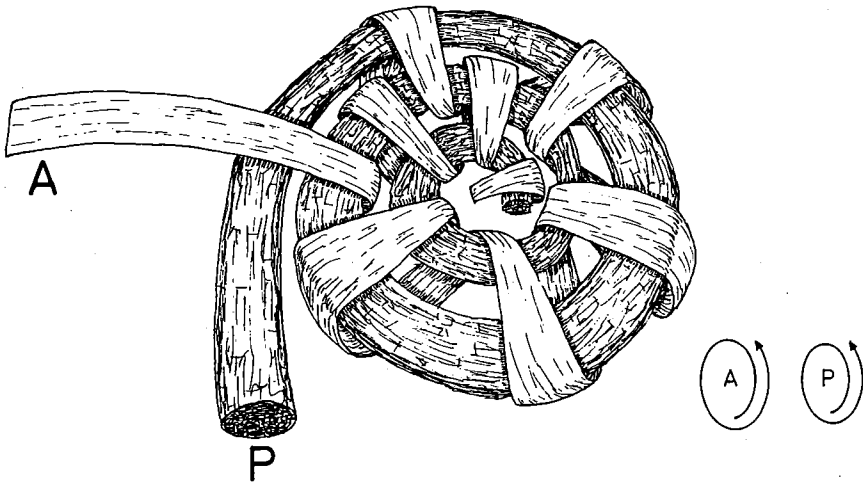

Figure 33. Basketry technique with two systems. Each system exists of one long element. Element P (the passive element) is coiled in order to form the body of the technique. Element A (the active element) keeps together the passive elements by repeatedly winding around two strands of the passive element, while following its coil. Thus the active element causes the coherency of the structure.

course the strip is only in theory one element: the raw material for basketry never has sufficient length to make an entire basket with one strip. Since the insertion of new material always is done at the end of an exhausted strip, and in no way parallel to it, we still consider the sequence of different strips to be one element: the technique is always worked with one element at a time. The determination whether we are dealing with one element or with a set should be based on a study of the way in which the entire basket is set up.

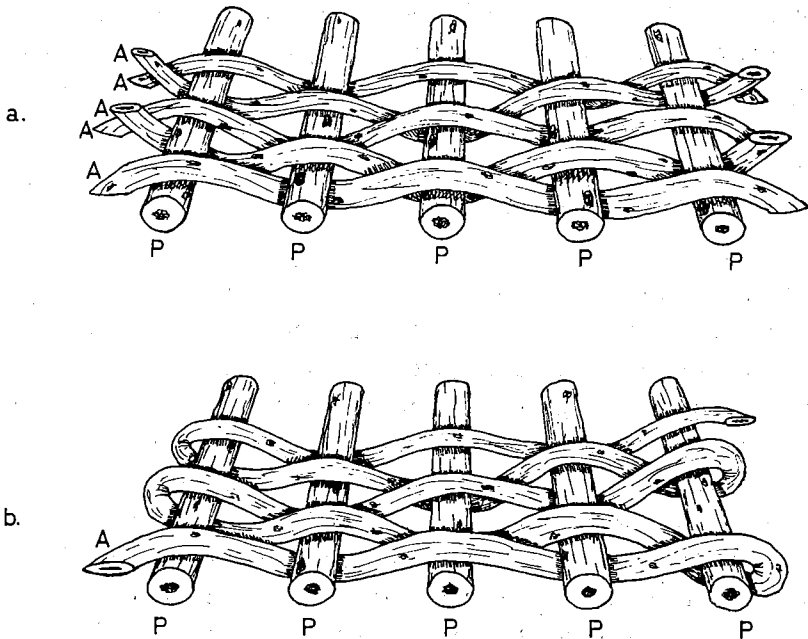

Figure 34. Two basketry techniques, both with a set of passive elements (P,P,P,P,P). 34a. a set of active elements (A,A,A,A,A); 34b. one active element (A).

Figure 34 illustrates how two techniques which are similar in appearance, can be made by either one (Figure 34a) or a set of active elements (Figure 34b). The same difference occurs in Figures 35a and 35b, the first consisting of a set of passive elements, held together by a set of active elements, while in the second drawing one active element is responsible for the coherency of the seven passive elements.¹⁰

active / passive

For each system it should be established whether its role in the technique is active or passive. A system is active when it has an active role in obtaining the coherency in a technique. A system is passive when it has no connective function, apart from forming the body of the technique. In Figures 26-28 the passive, rigid elements are held together by the more flexible active members. In Figure 29 and 33 the passive strand is fastened by the active winding strip.

Often the distinction is not made solely on the basis of technical details, by looking at the structure, but also on that of technological points. The technological difference relates to the production process of the object: in the process of making the basket, the active elements are handled by the basket-maker while the passive elements often are either fastened at one end to secure their position, or left untouched during the process.

number of members:

The elements can be made up of one strand, or a number of strands. The strands which make up an element are indicated as the 'members' of the element. In Figures 26 - 29, however, all elements consist of one member. Figure 36 illustrates elements of one member (a); elements consisting of two members (b, d and e), and three-membered elements (c, f and g). A set of passive elements (system p) is similar to the passive system of Figures 26-29. The active elements, however, are different. The familiar element (a) consists of one member and has been woven under 1 / over 1 passive element. Elements (b) and (c) consist of respectively two and three parallel members, woven in the same pattern as element (a). Number (d) indicates two members which interact: they have been paired to form one

¹⁰ Note that the number of passive elements differs in the two drawings of Figure 35. When only one active element is involved an odd number of passive elements is required. The reason lies in the 'over 1 / under 1' - pattern. For a set of active elements the number of passive elements is of no consequence, since a variable number of active elements can be inserted.

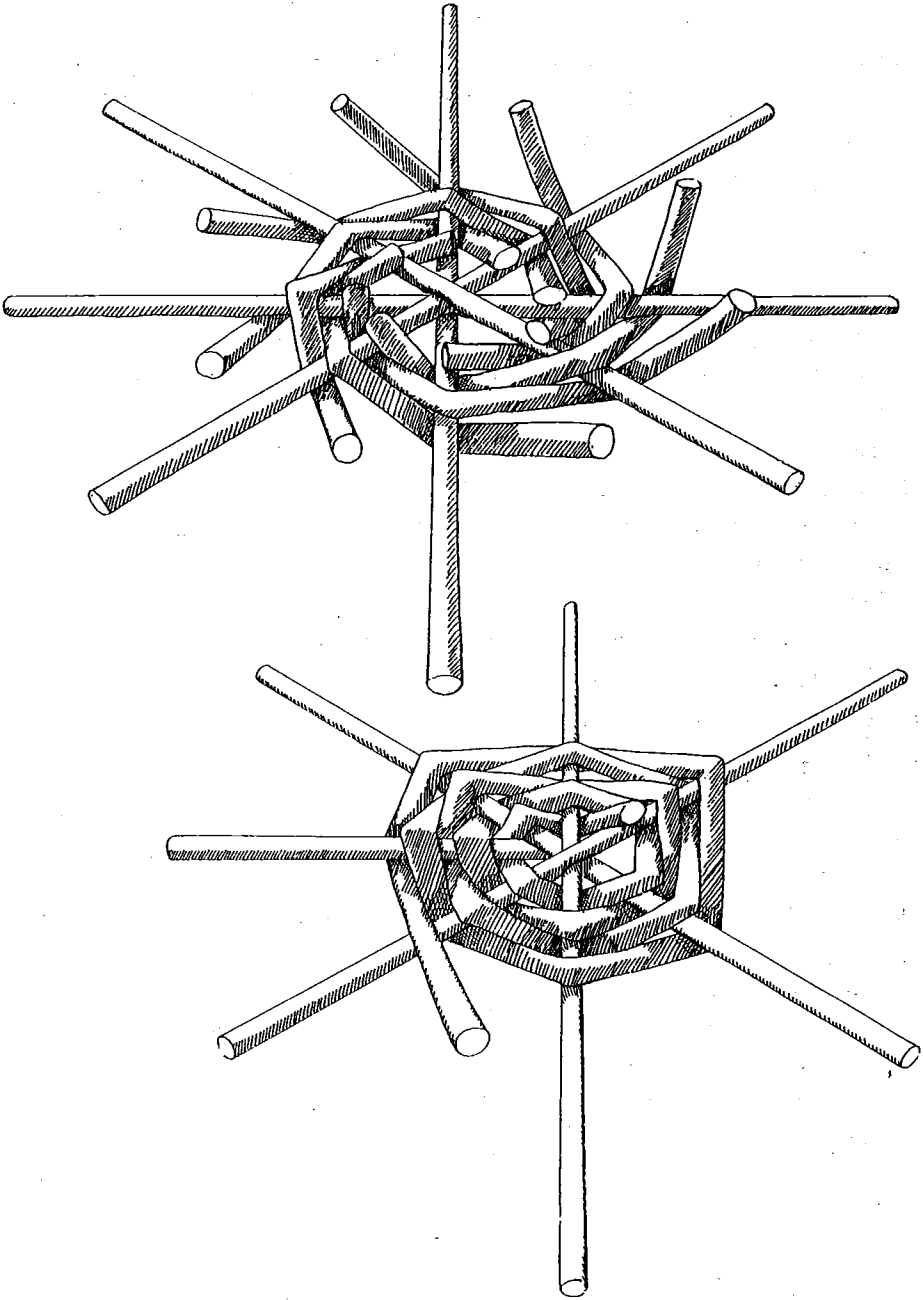

Figure 35. Two basketry techniques. 35a. a set of eight active elements and a set of eight passive elements. 35b. one active element and a set of seven passive elements (drawing by Vera Boots).

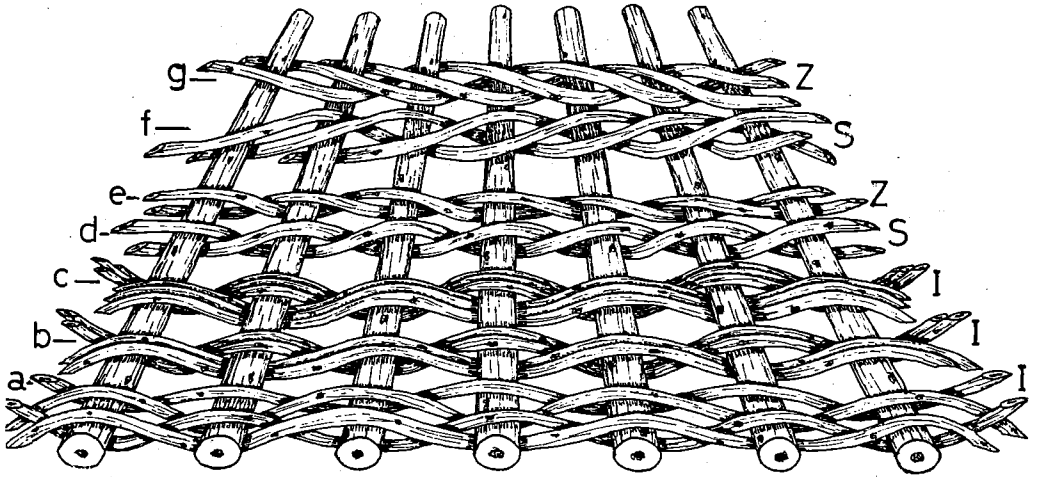

Figure 36. Seven basketry techniques: a. weaving under 1 / over 1 with one member; b. weaving under 1 / over 1 with two members, also known as *slewing* with two rods; .c. weaving under 1 / over 1 with three members, also known as *slewing* with three rods; d. pairing two strands in S-direction (*twining*); e. pairing two strands in Z-direction (*twining*); f. interaction with three members (*waling*) in S-direction, pattern: under 1 / over 2; g. interaction with three members (*waling*) in Z-direction, pattern: under 1 / over 2.

element. This technique is often indicated as *pairing* or *twining*. Figure 36 also indicates that whenever more than one member is engaged in an element, there are again three possible orientations: S, Z and I.

The same principle, an element built of more than one member, is indicated by number (e). This element consists of three members. Again there is a difference in orientation. The pattern of the members is over 2 / under 1. Combinations of four or more members do occur as well. The pattern is adapted to the number of members involved. For a four-membered element the pattern can be 'under 2 / over 2' or 'under 1 / over 3' or 'under 3, over 1', as long as the total number counts up to four. The combination of more than two members in an element is known in basket makers' terminology as *waling*. The reason for applying more members into one element is the strengthening of the structure. It is thus applied often in the shaping of a basket, since the stronger multi-membered elements can be used to force the passive members into place.

preparatory work**none / corded / plaited / other:**

This heading indicates the way in which the elements of the different systems have been prepared before being used.¹¹ The circling of one of the options is followed by specifications of the technique applied.

none []

No preparation has been applied. The raw material is worked up in its original shape and size.¹²

corded [] / corded: system no. []**sP[C]:**

CIp _____ x 100

CIc _____ x 100

String is made up of fibres or plant parts. In the section 'corded: system no. []', the rope system is indicated. The technique of cordage is indicated by determining the direction of spin, ply and cable and calculating the Cord Index (see pages 31-32 and 33-38).

reg/irr.

This entry indicates the regular or irregular character of the cords. Especially the regularity of the Cord Indices has to be noted.

plaited [] / plaited: system no. []

Strings, leaves or bundles of fibres which have been plaited before being incorporated in the basket or mat, are described separately. The details on the method of plaiting are recorded in the 'plaited system' section, in which a reference to the main description of the system is included.

Plaiting is carried out with different numbers of strands, and in a number of different patterns. The Plait Index should be calculated and from this the angle of plait. All of these entries need a more detailed explanation:

no. of strands []

Plaiting can be described as a basketry technique in its own right. The plaited strips are part of one system, consisting of a limited number of elements, which are all active in the plaiting process. The fact that only one system is involved is

¹¹ Preparation of the raw material, by retting, beating, combing or otherwise, should be recorded separately under 'MATERIAL' (section 5.7).

¹² The dimensions of the raw material are recorded in block 3, DIMENSIONS (see page 86).

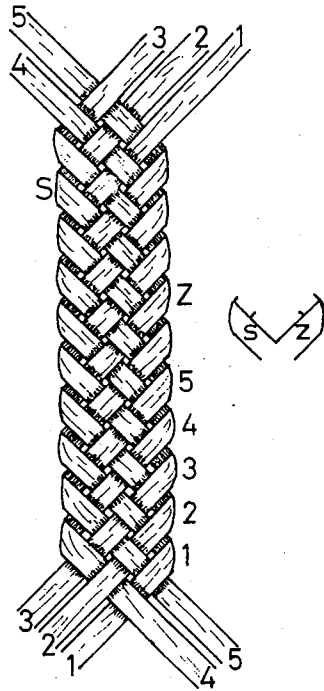
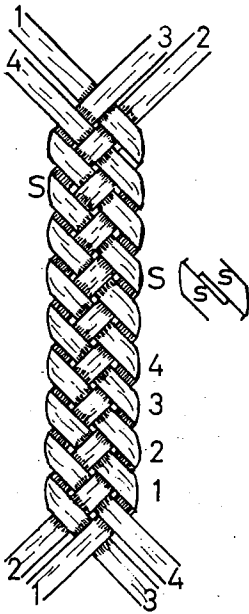

Figure 37. Four-strand plait, pattern 1 / 1 / 1 (under 1 / over 1 / shift 1) Figure 38. Five-strand plait, pattern 1 / 1 / 1 (under 1 / over 1 / shift 1)

made clear when we look at the edge of a plait, where the strips change direction and turn back into the plait. The elements thus change roles, each time one strand being actively interwoven with the others, which at that moment could be considered as 'passive' (see Figures 37 and 38). Counting the number of strands seems a complicated task at first, especially when the plaited strips are sewn together to form one ongoing fabric. There are, however, a number of 'rules' which limit the possibilities considerably.

When comparing the edges of a plait made up of four strands with one made of five strands (Figures 37 and 38), an important difference is noticed. At the right edge of the four-strand plait in Figure 37, strand 1 comes out from *under* strand 4, turns upwards and returns into the plait *over* strand 2. At the left edge, however, strand 1 goes *over* strand 4 and turns *under* strand 2. In the five-strand plait (Figure 38) the edge has a different appearance: here strand 1 goes *over* strand 5, turns and goes *under* strand 2, *both at the right and the left edge*.

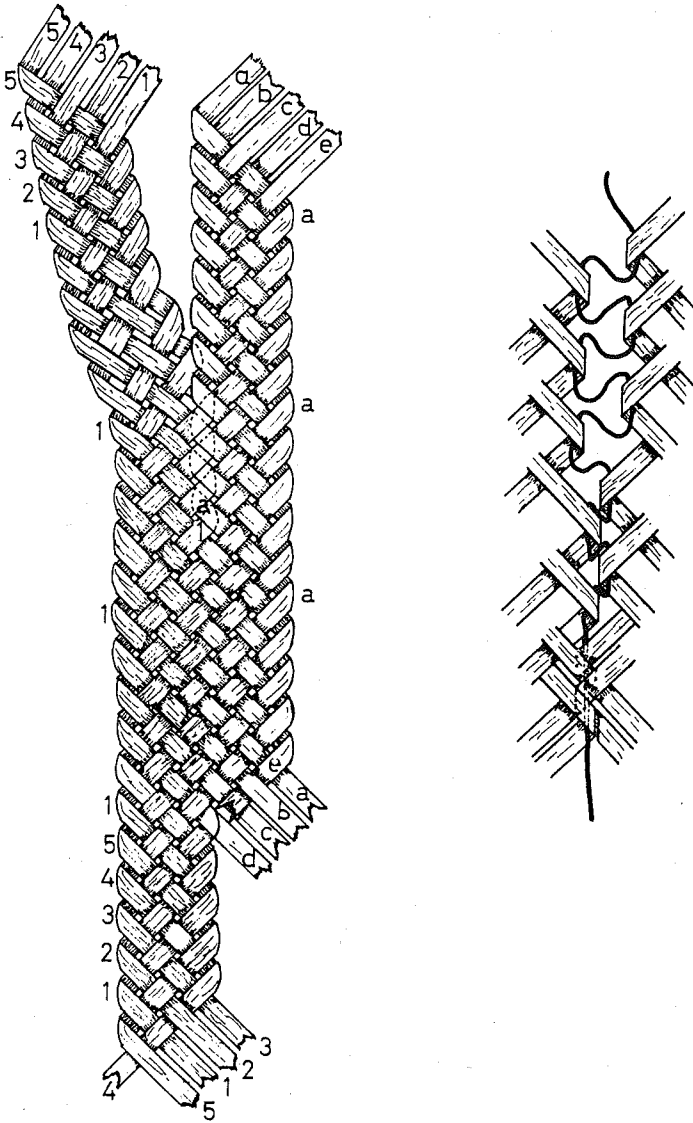

Figure 39. Two five-strand plaits sewn together. Because the edges are pulled inside each other, the strands seem to continue. In reality the strands make a full turn in the middle of the pattern. 39b. Detail of sewing the two plait edges with string.

The plait edges can be compared, similar to the direction of the spin, ply and cable, with the middle stroke of either the letter S or Z. In the case of a four-strand plait both edges show an S-direction. The edges of a five-strand plait are both orientated in a different way: the right edge a Z-direction, the left edge an S-direction. In general a five strand plait has a V-shape.

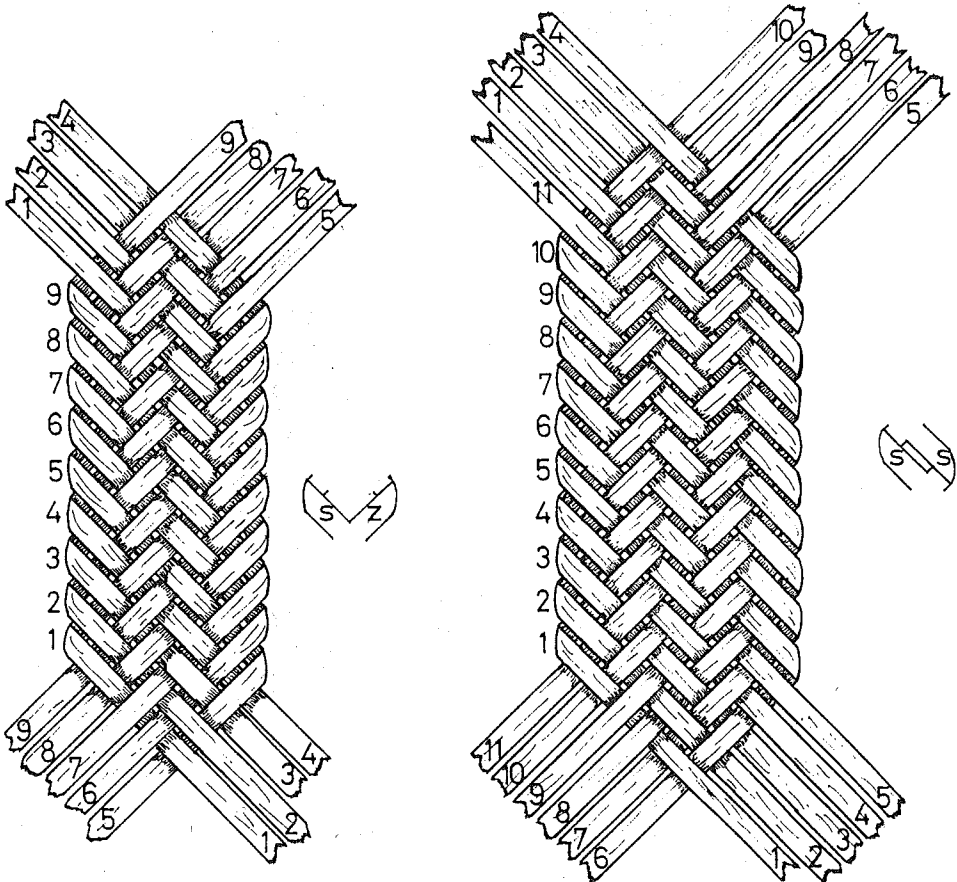

Figure 40. Nine-strand plait, pattern 2 / 2 / 1. Figure 41. Eleven-strand plait, pattern 2 / 2 / 1.

Thus plaits with an even number of strands have edges in the same direction, and plaits with an odd number of strands have edges which form a V-shape, both edges being differently orientated.

When plaits are prepared for being sewn into baskets the plaits made from an odd number of strands have a great advantage over the even numbered plaits.

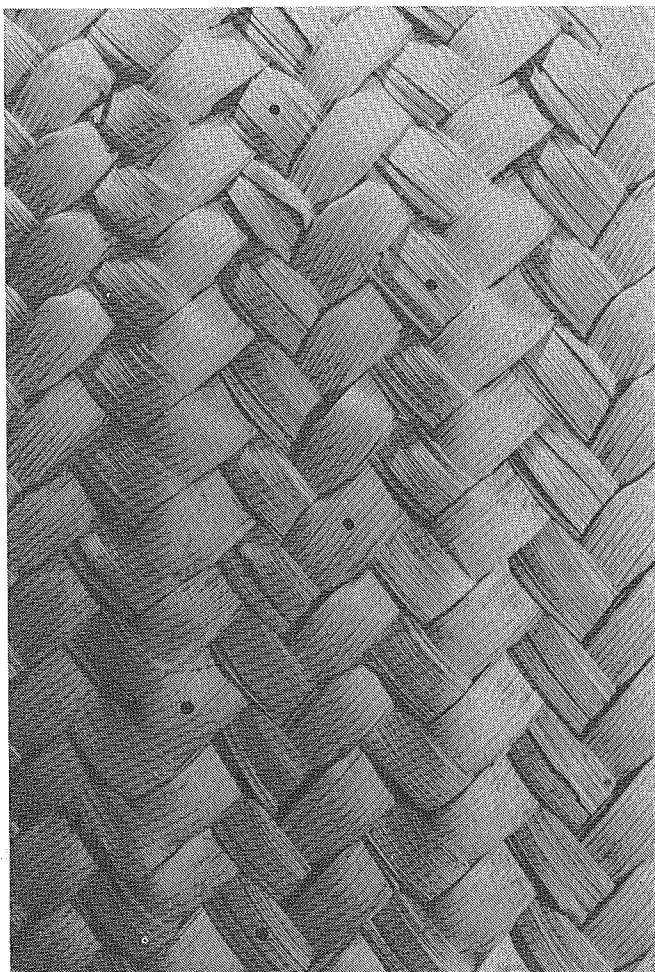

Plate 7. Three nine-strand plaits, pattern 2 / 2 / 1, sewn together. The two vertical protruding lines indicate the situation of the connecting string. One strand of the middle plait is highlighted by five black dots.

The edges of the odd numbered plaits can be fitted into each other as to form one ongoing pattern (see Figure 39). The plaits can thus be sewn together with string which pulls the edges together. In this manner the edges become invisible.

A similar difference in orientation occurs for the so called *twill* patterns (see page 66). Twill plaits can only be made with an odd number of strands, with a minimum of five strands (1 strand which goes under 2 and over 2 = 5).

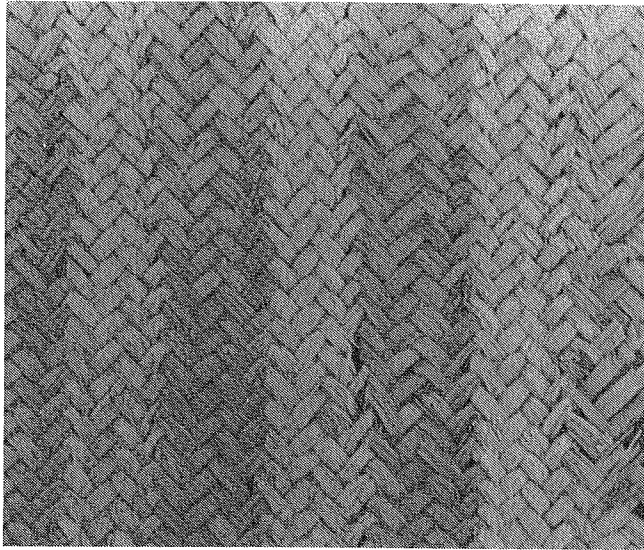

Plate 8. Fragment of a mat from Qasr Ibrim (Egypt). The nine-strand plaits are executed in contrasting colours. This mat dates probably from the 5th century AD. Courtesy to the Egypt Exploration Society, London.

The same mechanism which we have spotted in the four and five plait can be noticed in this pattern.

Figure 40 shows a nine-strand plait and Figure 41 an eleven-strand plait. The right edge of the nine-strand plait shows a Z direction, the left edge an S-direction (in fact the nine-strand plait consists of two V-shapes). The eleven-strand plait again has two edges in an S-direction which are not suitable for sewing into one ongoing pattern. For plaits in an 'under 2 / over 2 - shift 1' pattern, the number of strands most likely to occur will be either 9, 13, 17 or 21 (showing respectively two, three, four and five V-shapes). Plate 7 and Plate 8 illustrate the appearance of nine-strand plaits sewn together. In Plate 7 two vertical lines indicate where the string holds together the plaits. The black dots point out one particular strand. Plate 8 is a fragment from the Egyptian site of Qasr Ibrim (fifth century A.D.). Here the plaits can be distinguished with ease, because they have been executed in different colours.

under / over / shift (plait patterns)

Figures 42 to 45 show four-plait patterns.¹³ The patterns are indicated by the number of strands which are crossed and the shift which occurs. Thus Figure 42 is an 'under 1 / over 1 / shift 1' pattern. Strand i goes under strand A, over strand B. The next strand shifts one step: strand ii goes over A, under B and over C. The 'under 1 / over 1 / shift 0' - pattern of Figure 43 illustrates that without a shift in the pattern, the elements are simply arranged on top of each other. It is the shift which creates the coherency of the structure.

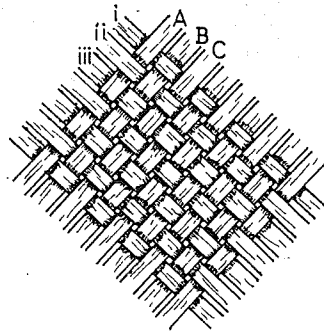

Figure 42. Plait pattern 1 / 1 / 1
(under 1 / over 1 / shift 1).

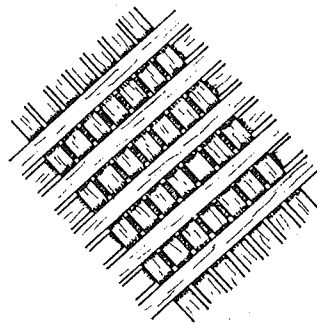

Figure 43. Hypothetical plait pattern
1 / 1 / 0 (under 1 / over 1 / shift 0).

¹³ The patterns are presented here as if they consist of two different systems, an active and a passive one. Instead of an 'active' strand which passes over and under a 'passive' strand, plaits consist in reality of one system, in which the elements change direction, as is clearly visible in Figures 37 to 41.

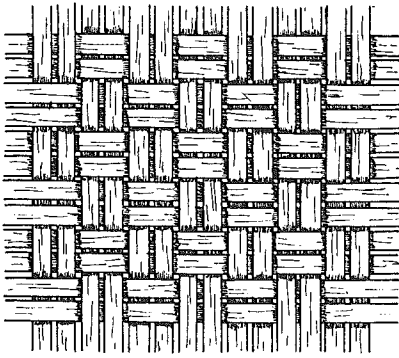

Figure 44. Plait pattern 2 / 2 / 2
(under 2 / over 2 / shift 2).

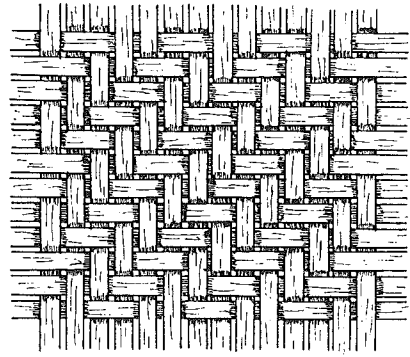

Figure 45. Plait pattern 2 / 2 / 1
(under 2 / over 2 / shift 1).

Figure 44 and 45 both show an 'under 2 / over 2' pattern. The difference is determined by the shifts. In Figure 44 the shift is two. Here we see a repetition of the pattern of Figure 42, with double strands.¹⁴ In Figure 45 the shift is one. The change of appearance is substantial. In textile terminology this pattern is indicated as a *twill*. It has an oblique appearance because the shift is less than the number of strands which are passed by the crossing element. A pattern in which the shift is identical to the number of strands which are passed over and under, is known as a *tabby* (Figures 42 and 44).

PI:

angle of plait:

Plait Index (PI) and angle of plait: The angle of plait, which is the angle at which the strands meet, is not always 90°, as the drawings in Figures 37-45 would suggest. There is quite a variation in angle of plait, due to the difference in force with which the strands are pulled. Since it is difficult to obtain reliable results by measuring the angle of plait with a protractor, it is better to determine an average value first. This can be done by determining the Plait Index. Figures 46 and 47

¹⁴ The pattern of Figure 39 can be indicated by 'under 2 / over 2 / shift 2', but for reasons of consistency, it is preferable to use the description 'under 1 / over 1 / shift 1' with active elements consisting of two members (see Figure 36 b).

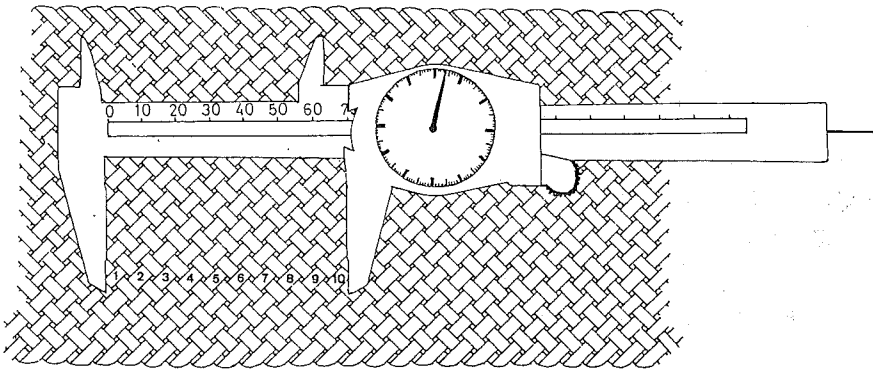

Figure 46. Measuring the Plait Index: the width of the plaiting strands is measured and multiplied by a random number of strands (here: 10). The outcome is divided by the length over which the ten strands extend (here: 70.3 mm.). This number is then multiplied by 141.421

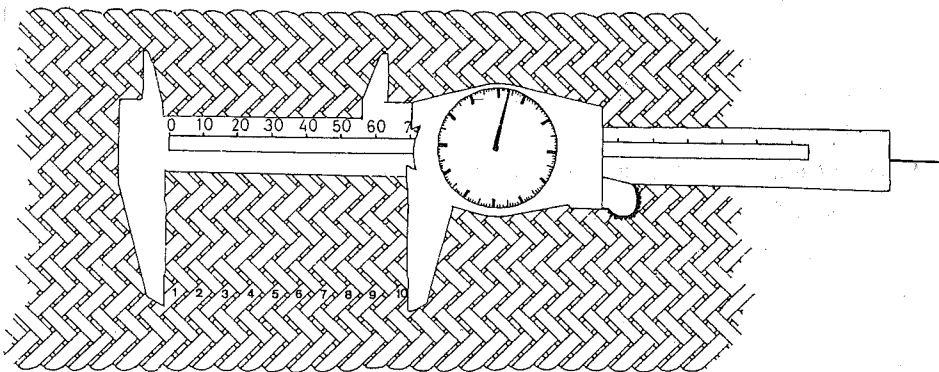

Figure 47. Measuring the Plait Index in twill plaits: for measuring the length over which the random number of strands (here: 10) extends, the calipers are put halfway the first strand, at the spot at which one cross strand meets.

illustrate how the values for the Plait Index are measured in tabby and twill plaits. A random number of strands (n), usually a number of ten, is multiplied by the average width of the strands (w). This number is then divided by the length over which the strands extend in the plait (l).

For twill patterns (Figure 47) the measuring starts half way the first strand, at the point at which the strand number 1 crosses the shift.

In formula:

$$PI = \frac{n \times w}{l} \times 141.421^{15}$$

The Plait Index (PI) gives an indication of the angle at which the strands meet. An obtuse angle yields a PI over 100, an acute angle, one below 100. The ratio in the formula can be used to calculate the exact angle of plait. This can be done by using a pocket calculator with an *inverse sine* mode¹⁶, since the ratio is the sine of half the angle between the strands.

In formula:

$$\text{angle of plait} = \text{arc.sin} \left(\frac{nxw}{l} \right) \times 2$$

reg/irr.

At this point the researcher may indicate whether the plaiting, and especially the angle of plait, is regular or irregular.

other:

After none [] / corded [] / plaited [], the final entry in the list of preparatory work is 'other'. The recording sheet has no further specifications for this entry.

In order to obtain an even shape, the material can be prepared by splitting or cutting. For instance willow rods can be split, planed and cut into long strands of exactly the same width and thickness. These strands are known in basket-makers' terminology as *skeins*. Another method of preparation frequently used is that of *twisting*. This technique is used for instance for wood from one or two year

¹⁵ Since the Plait Index is calculated from half the angle at which the strands meet, the PI indicating an angle of 90° would be 0.70710 (SIN 45°). To obtain a more convenient number, the sine is multiplied by 100/SIN 45° (= 141.42136). In this way the PI of 90° is 100.

¹⁶ Apart from calculating the angle of plait by using a pocket calculator, it is also possible to estimate the angle from the Tabel given in Appendix B. The Tabel lists a number of values of the *Plait Angle Index*. This is the Plait Index, multiplied by a constant number 141.421.

old trees, in which the fibres are loosened by turning the rod at one end while the other end is wedged.

When all information on each separate system has been recorded, it is essential to record the way in which the systems interact. Often several structures occur in one basket. Usually these structures are all based on the same number of systems, the activity of the systems being constant throughout the basket. The different ways of interaction are indicated in schematic drawings in the sections on base, side and rim.

Two more entries are dealing with the basic structure and the way the different systems interact: facing system and flexibility.

facing system:

When one system is dominating the appearance of a basketry object, this system is indicated as the 'facing system'. Plate 9 shows a technique in which the active system, made out of grass leaves (system 2), hides the passive system, made out of grass strings (system 1). In this case system 2 is the facing system. In Plate 10 the passive system (system 1) is still visible, but the active system is clearly dominant.

Plate 9. Mat from the workmen's village at Tell el 'Amarna (Egypt). The mat dates from circa 1350 BC. The passive elements (vertical) consist of grass string. For the active elements (horizontal) grass leaves were used. Inset: detail of the weave. The string is not visible between the grass leaves. Courtesy to the Egypt Exploration Society, London.

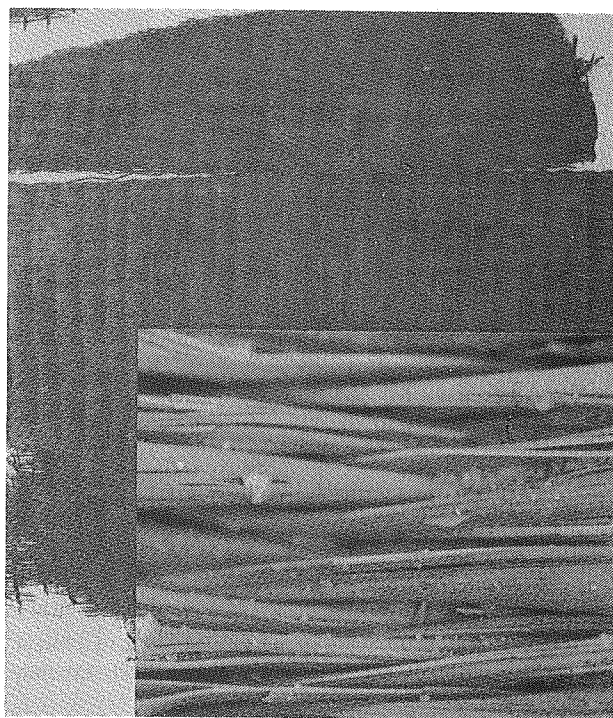

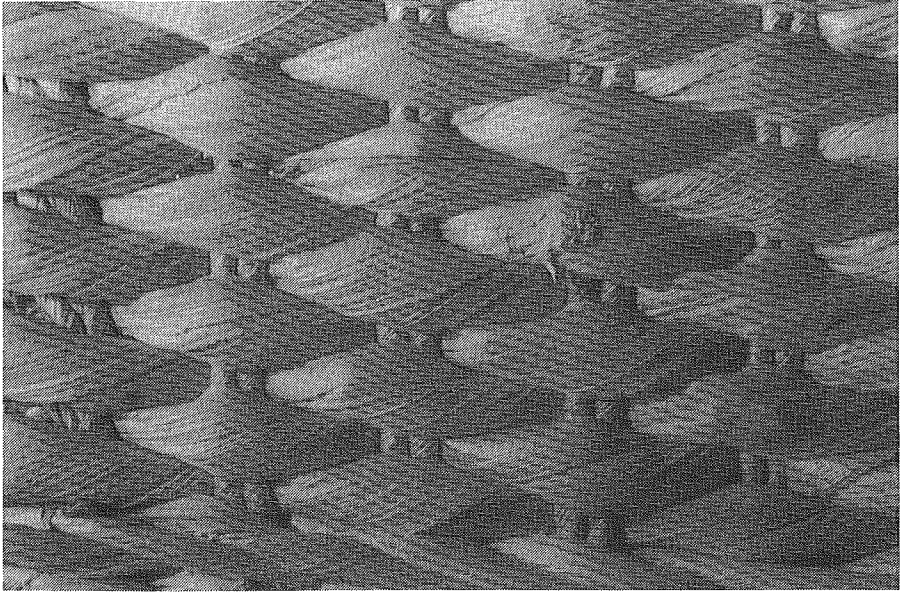

Plate 10. Detail of a modern basket. The passive elements (vertical) are barely visible, due to the fact that the active elements (horizontal) exceed the passive elements in size. Furthermore, the active elements have been pushed closely together.

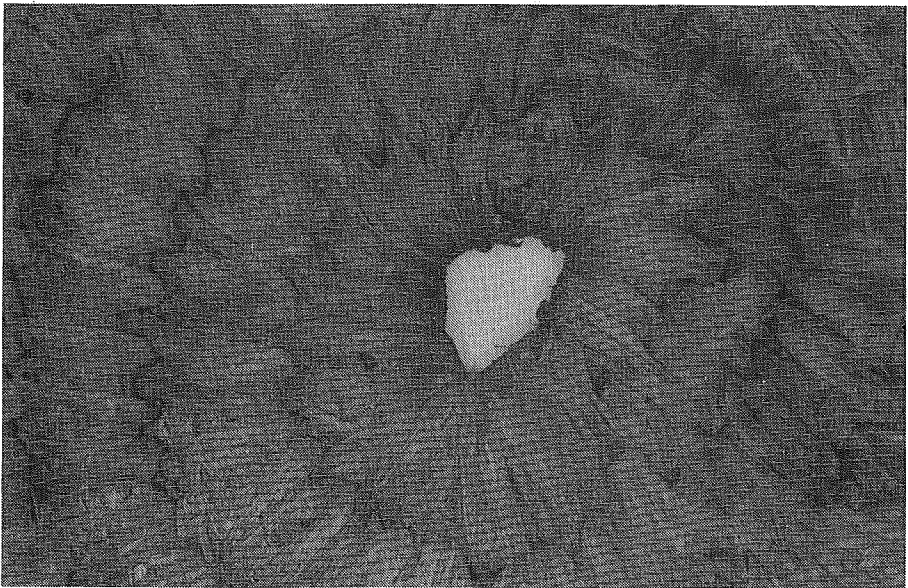

Plate 11. Detail of a basket from the workmen's village at Tell el 'Amarna (Egypt, circa 1350 BC). It is only due to wear, that the passive bundle, consisting of grass, is visible. The active element (Dom palm leaf) originally covered the grass bundle completely. Courtesy to the Egypt Exploration Society, London.

In Plate 11 the passive system (system 1) consists of a bundle of grass leaves, which is coiled. The passive bundle is held together by an active system made up of palm leaves (system 2). Since the bundle is barely visible due to the almost complete cover of the palm leaves, system 2 is considered the facing system.

rigid

flexible

semi-flex.

In one of the boxes the flexibility is indicated of the original object. Rigid basketry is often made of wood-like materials. Such an object remains in one shape, even when some pressure is put to the sides. Flexible basketry is characterized by the fact that its shape is not permanent. When the contents are removed, the basket simply collapses. In general one refers to this type of basketry objects as bags, sacks, or mats if they are two-dimensional. Usually flexible materials such as grass or flax are used as raw materials. Semi-flexible basketry retains its shape, but can be pushed into a different shape. Baskets made of palm leaf have this kind of semi-flexibility.

| | | | |
|---|---|---|---|
| <p>2. TECHNIQUE</p> <p>BASIC STRUCTURE</p> <p>no. of systems ()</p> <p>System 1</p> <p>one element/set of elements</p> <p>active/passive</p> <p>no. of members () S/Z/I</p> <p>preparatory work</p> <p>none <input type="checkbox"/> corded <input type="checkbox"/> plaited <input type="checkbox"/></p> <p>other:</p> <p>System 2</p> <p>one element/set of elements</p> <p>active/passive</p> <p>no. of members () S/Z/I</p> <p>preparatory work</p> <p>none <input type="checkbox"/> corded <input type="checkbox"/> plaited <input type="checkbox"/></p> <p>other:</p> <p>System 3</p> <p>one element/set of elements</p> <p>active/passive</p> <p>no. of members () S/Z/I</p> <p>preparatory work</p> <p>none <input type="checkbox"/> corded <input type="checkbox"/> plaited <input type="checkbox"/></p> <p>other:</p> | <p>plaited: system no. ()</p> <p>no. of strands ()</p> <p>under /over /shift</p> <p>Pt. ----- x100 =</p> <p>angle of plait:</p> <p>reg/irr.</p> <p>corded: system no. ()</p> <p>sP(C):</p> <p>Cl₁ ----- x100 =</p> <p>Cl₂ ----- x100 =</p> <p>Cl₃ ----- x100 =</p> <p>reg/irr.</p> <p>facing system: no. ()</p> <p>rigid <input type="checkbox"/></p> <p>flexible <input type="checkbox"/></p> <p>semi-flexible <input type="checkbox"/></p> <p>see page ...</p> | <p>BASE scheme of centre:</p> <p>orientation inside base: e / reversed e</p> <p>continuation (scheme):</p> <p>active system () passive system ()</p> <p>no. of elements: no. of elements:</p> <p>no. of rows: no. of rows:</p> <p>other systems (specif.):</p> <p>increasing (scheme):</p> <p>see page ...</p> | <p>SIDE scheme basic structure:</p> <p>orientation inside: e / reversed e</p> <p>active system () passive system ()</p> <p>no. of elements: no. of elements:</p> <p>no. of rows: no. of rows:</p> <p>other systems (specify):</p> <p>insertion/exhaustion:</p> |
| | <p>TRANSITION BASE-SIDE</p> <p>METHOD OF SHAPING</p> <p>description/drawing:</p> | <p>RIM, EDGE description/drawing:</p> | <p>OTHER</p> <p>description/drawing:</p> <p>see page ...</p> |

Figure 48. The part of the recording sheet on which the basketry technique is recorded. The unshaded part deals with the technical details of the different sections of the object.

2.2.2 Base (see Figure 48)

We have defined technique as the systems which make up the basic structure of a basket. The various elements of the systems have a beginning and an end. These two aspects should be treated as an integral part of the technique. Often the starting point is at the base of the basket.

scheme of centre:

Here the centre is recorded by a schematical drawing (not to scale). Figure 49 gives an example of such a drawing, which has no other task than to make clear at which point and in what way the making of the object is started. Additional examples are figure 50 and 51.

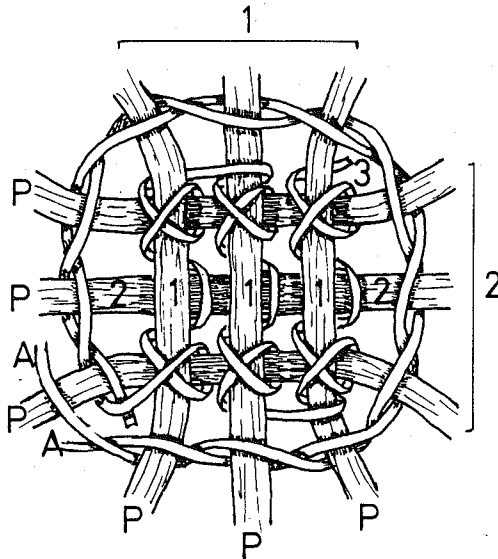

Figure 49. Drawing of the centre. Six elements of two passive systems (difference in orientation between system 1 and 2), have been tied together by an active system (no. 3). Beyond the actual centre, the two passive systems become part of one system (P) consisting of 12 passive elements, which are held together by an active system (A), consisting of one element with two paired members (see also Figure 51).

orientation inside base: e / reversed e

Bases with a starting point in the centre (usually round or oval bases) are orientated in either of two directions: clockwise or anti-clockwise. This is recorded by noting down the small letter e (anti-clockwise; see Figure 50) and its mirror image reversed e (clockwise; see Figure 51). When one side of the base is e-orientated,

the opposite side is always reversed-e orientated. Therefore the inside of a basket is the standard side from which the orientation is recorded. For mats and plates the orientation of the top side is used.¹⁷



Figure 50. An e-orientated (anti-clockwise) centre of a coiled basket.

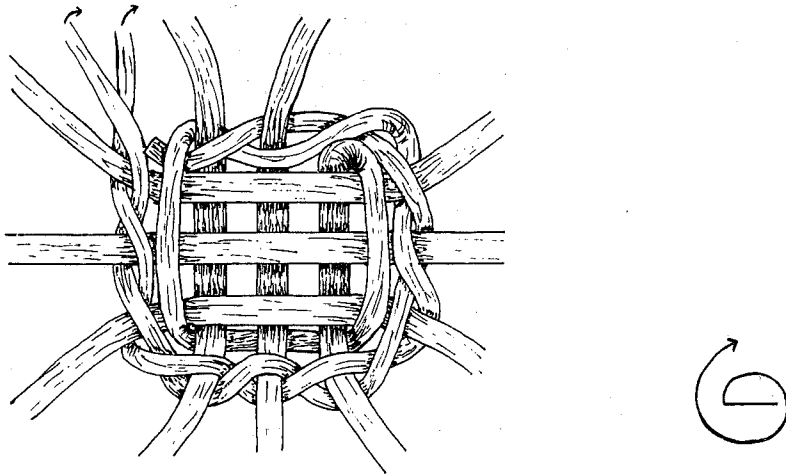

Figure 51. A reversed-e orientated (clockwise) centre of a stake-and-strand basket.

¹⁷ Deciding on what is the top and what the bottom side of a mat or basketry fragment can be facilitated by comparing the decoration (unless the mat is identical on both sides, the decorated side usually is the top), the insertion of new material (usually only visible at the bottom side) and the wear (different wear patterns on top and bottom side).

continuation:

When the material is fastened at the base, a repetitive pattern occurs. This pattern is the *basic structure*, which is either continued throughout the entire basket, or differs in several sections of the basket, for instance at the base and at the side of the object. A schematical drawing is only necessary if the basic structure of the base differs from that of the rest of the basket. Frequently the systems remain constant throughout the basket, but the way they interact varies. These variations in basic structure of the different parts of the basket have to be recorded by a schematic drawing. Examples of such drawings are Figures 52 and 53.

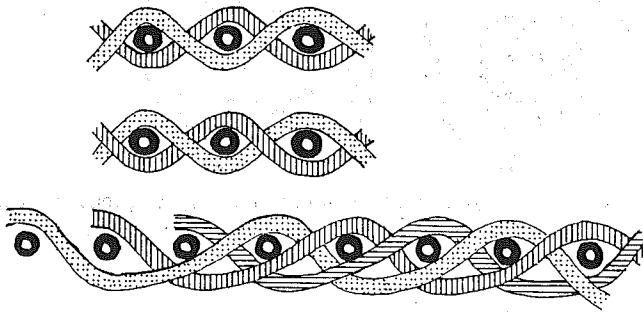

Figure 52. Three examples of schematical drawings of the basic structure. These cross sections represent the same techniques as have been shown in figure 36 (a, d and f).

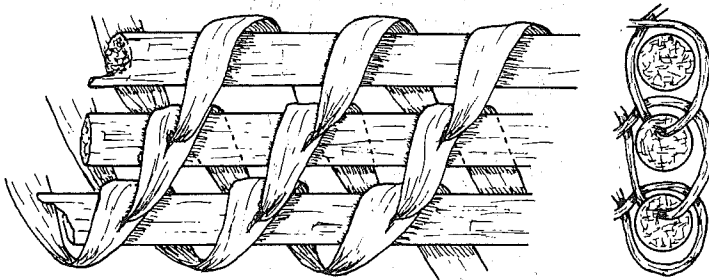

Figure 53. A schematical representation of a coiled basket. The drawing illustrates a section from the side of a coiled basket. A number of rows is shown and it is made clear in what way the active element stitches through the previous bundle. The drawback of representing this technique in section, is that the drawing does not indicate that the basket consists of one coiled bundle of material and one winding element (see Plate 13).

passive system**active system****no. of elements:****no. of elements:****no. of rows:****no. of rows:**

Figures 35 a and b. (see page 57) show not only that there is a difference between one active element and a set of active elements, but also that the difference between one and eight active strands requires a difference in the passive system as well. The technique as illustrated in Figure 35a has an even number of passive elements (eight stakes). Figure 35b shows an odd number of stakes (seven). When using one element in an 'over 1 / under 1' pattern, it is necessary to use an odd number of active elements, in order to get the shift, that is needed in order to end up in the opposite pattern ('over 1 / under 1') in the next row. When working with eight elements at a time it is not necessary to use an odd number of passive elements. It will be clear that the technique and the number of elements in a *set of elements* are interdependent. The number of elements therefore has to be recorded precisely. In Figure 35a both the passive and the active system consist of eight elements. In Figure 35b the passive system has seven elements (seven stakes), the active system only one (one strand).

The number of rows which are incorporated in the base, is in fact the number of times that the basketmaker has worked around the centre of a round or oval basket. Rows are counted separately for the base and for the side of a basket, unless the transition between base and side cannot be distinguished. In that case the total number of rows of the base and side is counted.

In Plate 12 the active element consists of two paired members. The number of rows from the centre to the transition into the side is seven. The number of rows in Plate 13 is seven for the base and three for the side. Here the rows are made up out of the coils of the passive element.

For baskets without a clear centre (often rectangular baskets or trays) the number of active elements that cross over the passive elements is counted. First the orientation of the active and passive system has to be determined. In Plate 14 the two systems are orientated at right angles. The number of *rows* is here the number of times that an active element crosses the passive elements. In this case we are dealing with ten rows. Each of the ten active elements as well as the passive stakes, which are crossed over, consists of four parallel willow rods.¹⁸

¹⁸ In the example of Plate 15 the number of rows is half the number of active elements. The tray consists of four passive and twenty active elements. Each passive element is crossed by ten active elements. Each element is made up out of four members in I-orientation (parallel to each other).

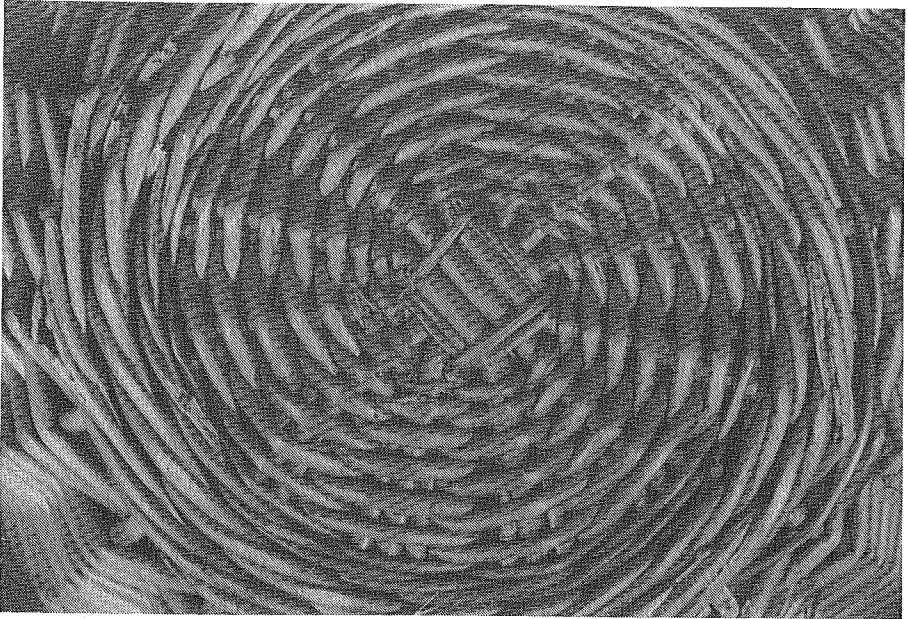

Plate 12. The outside of the base of a modern basket, consisting of seven rows of paired willow rods.

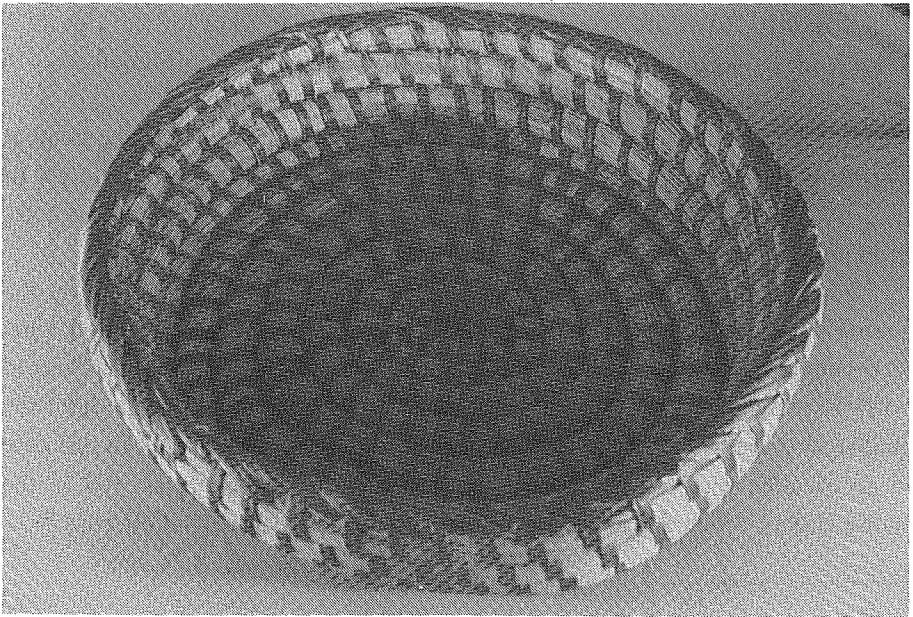

Plate 13. A modern coiled basket: seven rows in the base, three rows in the side.

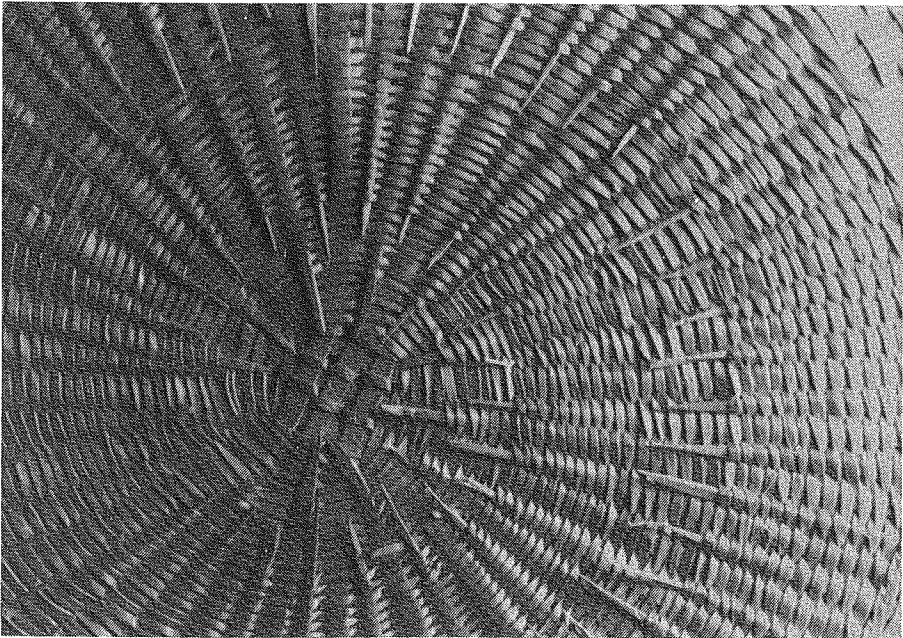
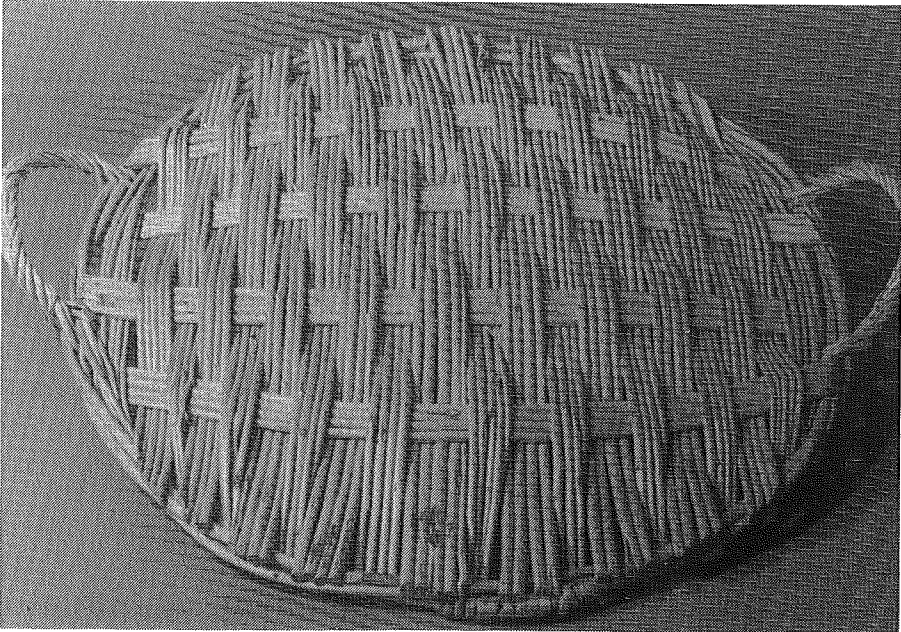

Plate 15. Outside of a base of a modern basket in *fine-skein* technique. In three stages additional passive elements have been inserted, these are visible as three circles of pointed sticks.

For basic structures such as illustrated in Plate 8 (page 64), in which both systems (the plaits and the string with which the plait is sewn into a mat) are orientated in the same direction, every plaited strip is considered to be a row. For the fragment of Plate 8 the number of rows visible is seven.

increasing:

In the base of baskets, in flaring sides and in mats the increase of size is visible. Especially in techniques with two different orientations, such as stake-and-strand techniques solutions have been applied to the problem of the widening space between the radiating passive elements. Sometimes the passive elements have been split to gain an even division of stakes. Often new stakes have been inserted in the outer rows of the base in order to limit the amount of space between the passive elements. This is clearly visible on Plate 15, the bottom side of a basket in 'fine-skein work'¹⁹.

2.2.3 Side (see Figure 48)

scheme basic structure:

The side of a basket is that part which rises from the base. Often the side is a continuation of the base. In many cases, however, the side is inserted separately after the base has been finished off. The technique in the side, or body, of a basket can deviate considerably from the technique in the base. The basic structure(s) which occur(s) at the side can be drawn schematically, just as in the section dealing with the base.

orientation inside basket: e / reversed e

The side, or body, of a basket has a specific orientation, which is expressed just like the orientation of the base as 'e' or 'reversed-e'. The orientation of base and side are not always identical. Plate 16 shows an 'e'-orientated side (anti-clockwise).²⁰

¹⁹ For the fine skein technique woodlike materials, such as willow rods, are split and alternately planed and cut into ever smaller strips until very thin, narrow strips remain. Very regular work can be made with wood prepared like this. Even the finest skeins have considerable strength since the weak core side is planed down, but the strong elastic bast side (the part of the rods just under the bark) is left.

²⁰ The significance of the orientation of base and side is not exactly clear. Similarities in orientation might indicate certain (local) traditions. A possible correlation between orientation and left or right-handedness has not been determined, yet.

passive system**no. of elements:****no. of rows:****active system****no. of elements:****no. of rows:**

Figures 35 a and b. (see page 57) show not only that there is a difference between one active element and a set of active elements, but also that the difference between one and eight active strands requires a difference in the passive system as well. The technique as illustrated in Figure 35a has an even number of passive elements (eight stakes). Figure 35b shows an odd number of stakes (seven). When using one element in an 'over 1 / under 1' pattern, it is necessary to use an odd number of active elements, in order to get the shift, that is needed in order to end up in the opposite pattern ('over 1 / under 1') in the next row. When working with eight elements at a time it is not necessary to use an odd number of passive elements. It will be clear that the technique and the number of elements in a *set of elements* are interdependent. The number of elements therefore has to be recorded precisely. In Figure 35a both the passive and the active system consist of eight elements. In Figure 35b the passive system has seven elements (seven stakes), the active system only one (one strand).

The number of rows which are incorporated in the base, is in fact the number of times that the basketmaker has worked around the centre of a round or oval basket. Rows are counted separately for the base and for the side of a basket, unless the transition between base and side cannot be distinguished. In that case the total number of rows of the base and side is counted.

In Plate 12 the active element consists of two paired members. The number of rows from the centre to the transition into the side is seven. The number of rows in Plate 13 is seven for the base and three for the side. Here the rows are made up out of the coils of the passive element.

For baskets without a clear centre (often rectangular baskets or trays) the number of active elements that cross over the passive elements is counted. First the orientation of the active and passive system has to be determined. In Plate 14 the two systems are orientated at right angles. The number of *rows* is here the number of times that an active element crosses the passive elements. In this case we are dealing with ten rows. Each of the ten active elements as well as the passive stakes, which are crossed over, consists of four parallel willow rods.¹⁸

¹⁸ In the example of Plate 15 the number of rows is half the number of active elements. The tray consists of four passive and twenty active elements. Each passive element is crossed by ten active elements. Each element is made up out of four members in I-orientation (parallel to each other).

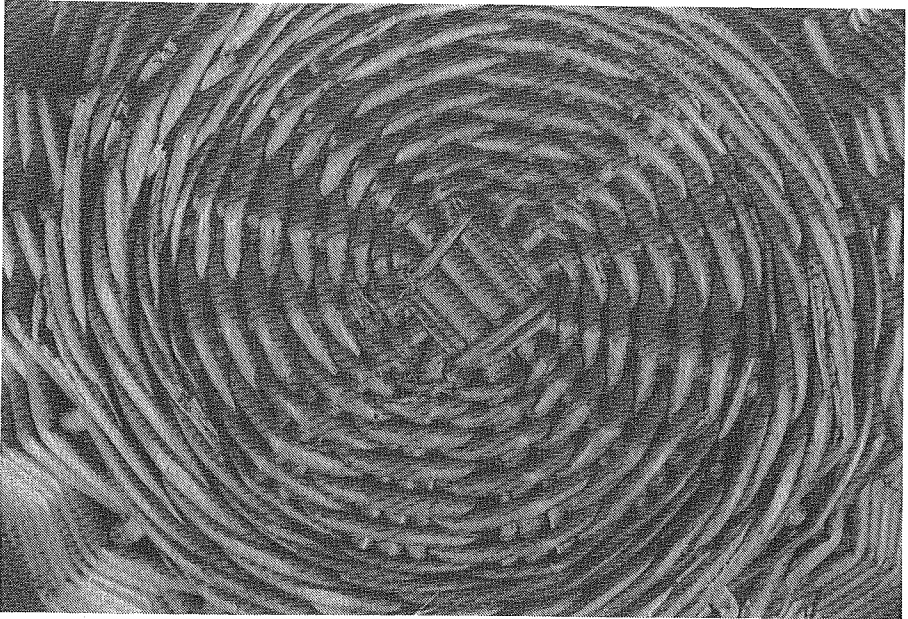

Plate 12. The outside of the base of a modern basket, consisting of seven rows of paired willow rods.

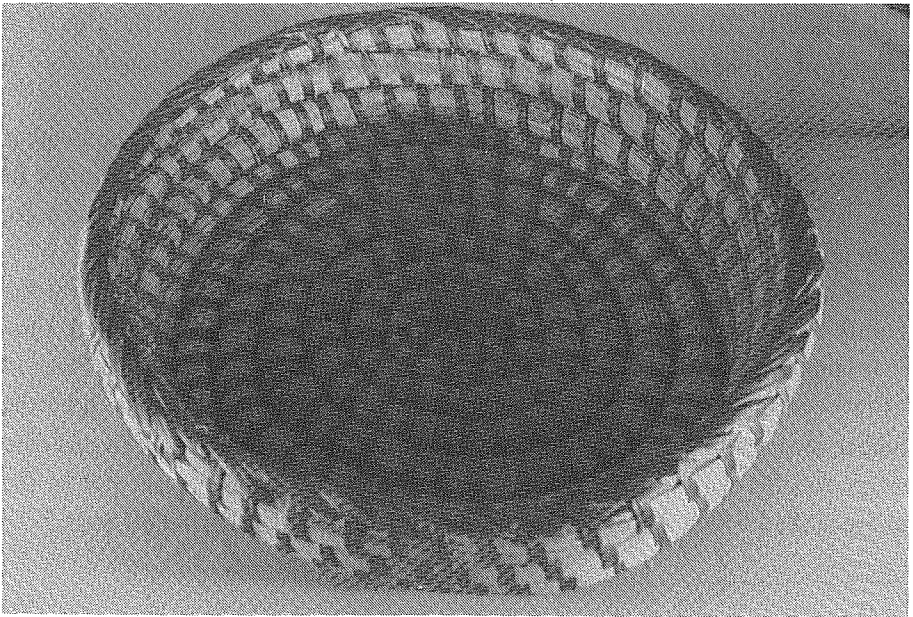

Plate 13. A modern coiled basket: seven rows in the base, three rows in the side.

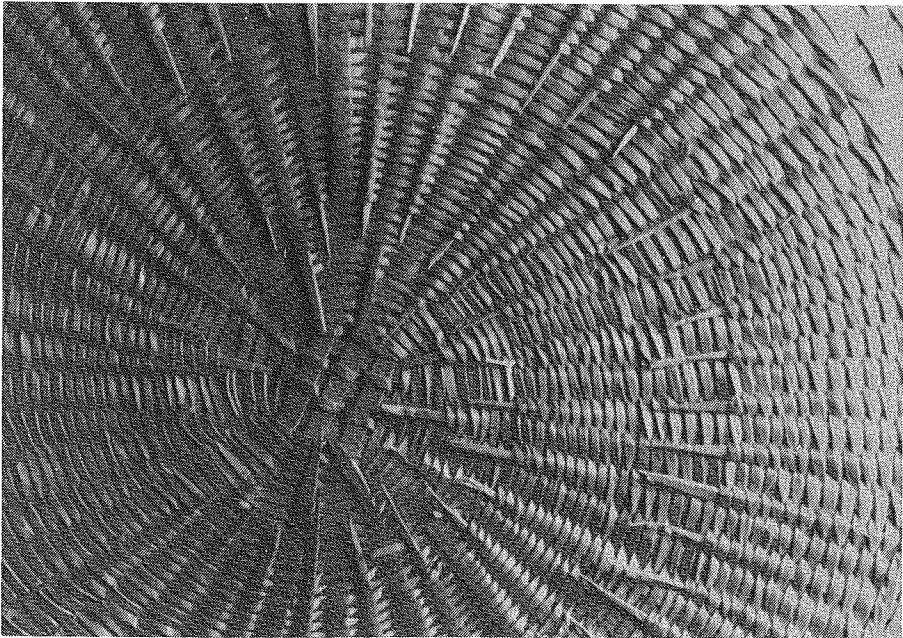
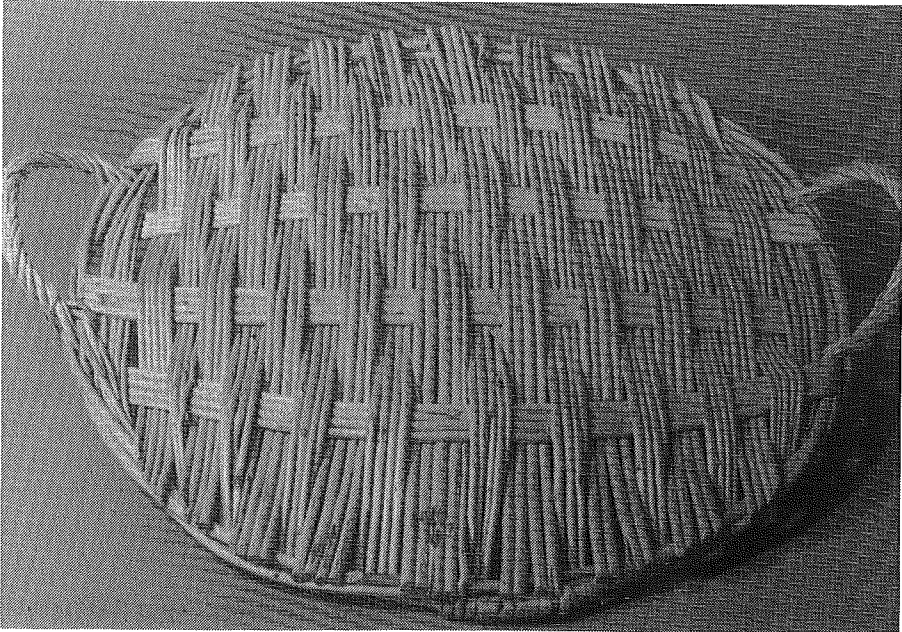

Plate 15. Outside of a base of a modern basket in *fine-skein* technique. In three stages additional passive elements have been inserted, these are visible as three circles of pointed sticks.

For basic structures such as illustrated in Plate 8 (page 64), in which both systems (the plaits and the string with which the plait is sewn into a mat) are orientated in the same direction, every plaited strip is considered to be a row. For the fragment of Plate 8 the number of rows visible is seven.

increasing:

In the base of baskets, in flaring sides and in mats the increase of size is visible. Especially in techniques with two different orientations, such as stake-and-strand techniques solutions have been applied to the problem of the widening space between the radiating passive elements. Sometimes the passive elements have been split to gain an even division of stakes. Often new stakes have been inserted in the outer rows of the base in order to limit the amount of space between the passive elements. This is clearly visible on Plate 15, the bottom side of a basket in 'fine-skein work'¹⁹.

2.2.3 Side (see Figure 48)

scheme basic structure:

The side of a basket is that part which rises from the base. Often the side is a continuation of the base. In many cases, however, the side is inserted separately after the base has been finished off. The technique in the side, or body, of a basket can deviate considerably from the technique in the base. The basic structure(s) which occur(s) at the side can be drawn schematically, just as in the section dealing with the base.

orientation inside basket: e / reversed e

The side, or body, of a basket has a specific orientation, which is expressed just like the orientation of the base as 'e' or 'reversed-e'. The orientation of base and side are not always identical. Plate 16 shows an 'e'-orientated side (anti-clockwise).²⁰

¹⁹ For the fine skein technique woodlike materials, such as willow rods, are split and alternately planed and cut into ever smaller strips until very thin, narrow strips remain. Very regular work can be made with wood prepared like this. Even the finest skeins have considerable strength since the weak core side is planed down, but the strong elastic bast side (the part of the rods just under the bark) is left.

²⁰ The significance of the orientation of base and side is not exactly clear. Similarities in orientation might indicate certain (local) traditions. A possible correlation between orientation and left or right-handedness has not been determined, yet.

passive system

no. of elements:

no. of rows:

active system

no. of elements:

no. of rows:

The same features are recorded for the side as for the base, namely the number of elements that form part of each system and the number of rows that has been inserted (see page 75).

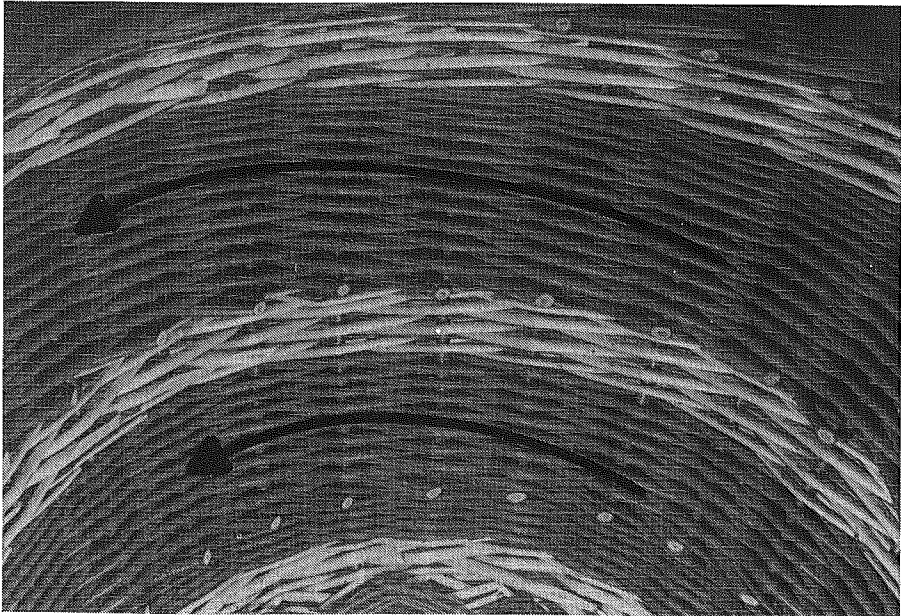

Plate 16. Inside of a stake-and-strand basket. The active elements have been inserted with the thick end of the willow rod (butt) and then worked up to the left. This is an example of an e-orientation of the inside of the basket.

other systems (specify):

If the number of systems involved in the basic structure exceeds two, the same information on the number of elements and rows has to be noted down for those systems. It should, of course, be specified which numbers belong to which system.

insertion/exhaustion:

Special attention should be paid to the way the raw material is integrated in the technique. The limited length of the raw material makes frequent insertion of new material necessary. Moreover, the raw material for basketry often retains the original plant shape. Date palm leaflets are 40 cm long, 1.5 cm wide and 3 mm thick. Willow rods are long twigs, with a tapered end: the length is about 2 m, the diameter is at the butt 20 mm and at the top 1 mm.²¹ The use of these two materials has clear consequences for the technique. When using willow rods in a stake-and-strand basket the rods cannot be woven randomly through the stakes, but an even distribution of the thick and thin ends is necessary in order to avoid a lopsided basket. There are several possible methods to achieve this aim, two of which have been illustrated in Figures 54 and 55.

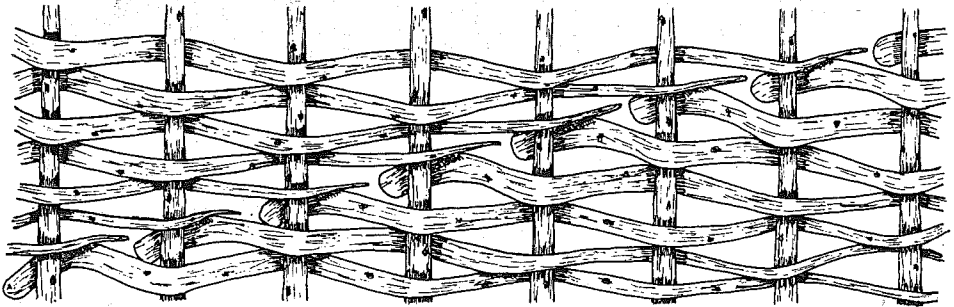

Figure 54. *English randing*: one willow rod is inserted at a time. The first willow rod is worked around until it reaches the starting point. Then the next rod is inserted, but this is done between the next to passive elements. By this method the thickness of the butts is evenly divided over the basket.

²¹ The dimensions of the raw material vary considerable, since they are natural products. The sizes as given here are an average, and form an example of the considerable variety of species of plant material.

Figure 54 is a sideview of a basketry technique which is generally known as *English randing*. Two systems are involved: a passive system (stakes) which includes a set of elements and an active system with one element. The active element is a willow rod ('weaver'), slightly thinner and more flexible than the stakes, which is inserted with the butt. The pattern is over 1 / under 1 / shift 1.

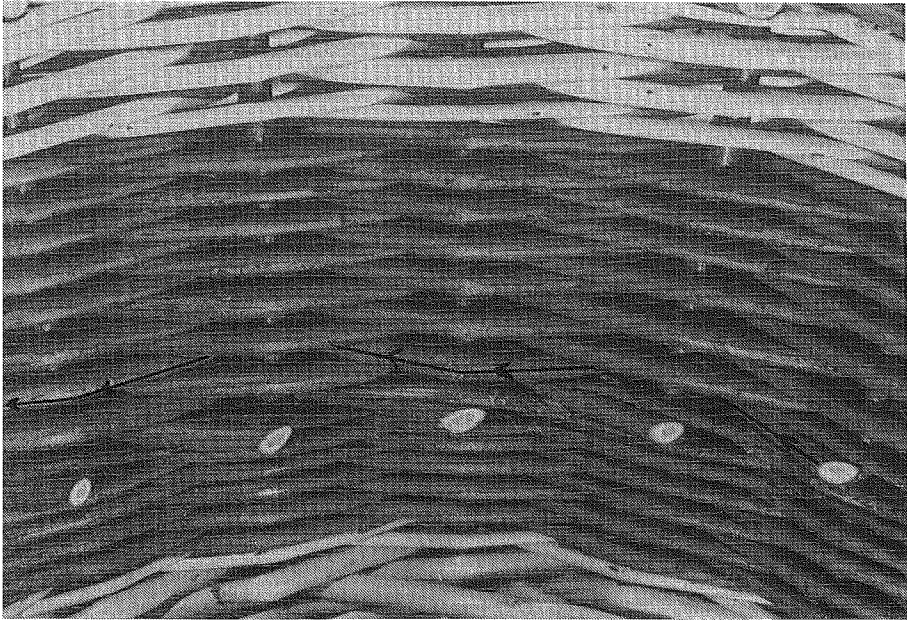

Plate 17. English randing.

The rod is exhausted after precisely one round and a new rod is inserted, one stake further than the first rod. This is continued until a rod has been inserted between every two stakes. Thus the effect of the differences in diameter between butt and top of the willow rods is eliminated. The black arrow in Plate 17 follows one willow rod in English randing. Note that the effect of the insertions of each active rod between the two passive stakes to the right of the previous one is a spiral, which is formed by the subsequent inserted butts.

Figure 55 illustrates a similar technique, but here the active system consists of a set of elements: between every two stakes a rod is inserted and all rods are worked in an over 1 / under 1 / shift 1 pattern until they are exhausted. In this way a division of thick butts and thin tops is achieved. Plate 18 shows the inside of a basket in this technique, which is known as *French randing*. The black arrow indicates one willow rod. Note that the willow rods are slanted slightly. All the

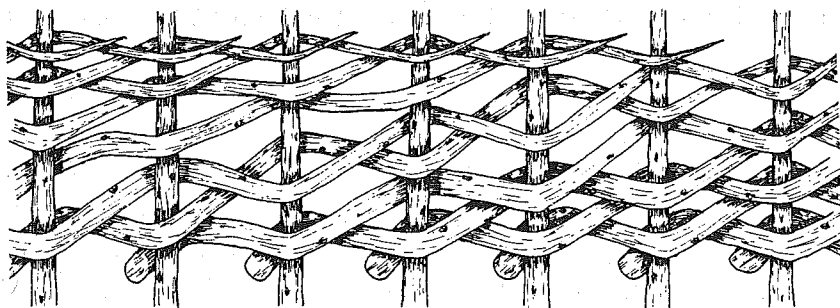

Figure 55. *French randing*: as many willow rods are inserted as there are spaces between the passive stakes. The rods are then worked up simultaneously.

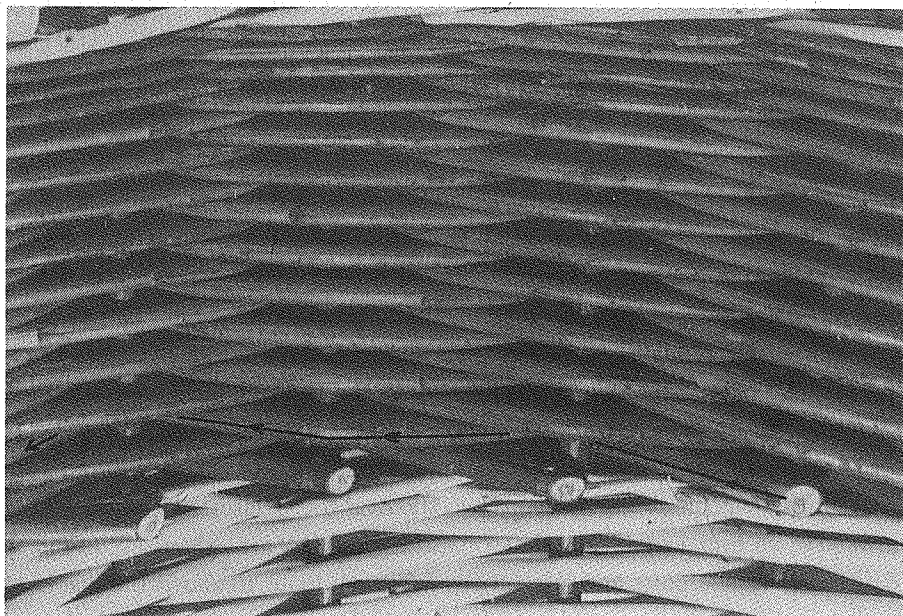

Plate 18. French randing

butts of the willow rods are visible just above the white at the bottom of the photograph, all tops of the rods can be seen at the top.

A further question is whether the insertion of new material shows consistency or not? Were all insertions started with the same end of the rod or leaf? Willow rods, for instance, can be inserted with the top or the butt. We have seen that in English randing all rods are inserted with the butt. Very often, however, a rod is inserted with the butt, exhausted at the top, after which a new rod is inserted with the top in order to avoid too large a contrast in diameter of the newly inserted material.

The detailed study of the insertions and exhaustions learns that the influence of tradition is in general very strong. Copying the appearance of a basket is possible, but the specific technical details which are not clearly visible have to be taught. In details of insertion and exhaustion, but also in details of the centre and rim of a basket it is often possible to trace the specific traditions of basket making.

2.2.4 Transition base - side, method of shaping (see Figure 48)

After recording the basic structures in both the base and the side, it is necessary to determine the transition between these structures. The reason that this transi-

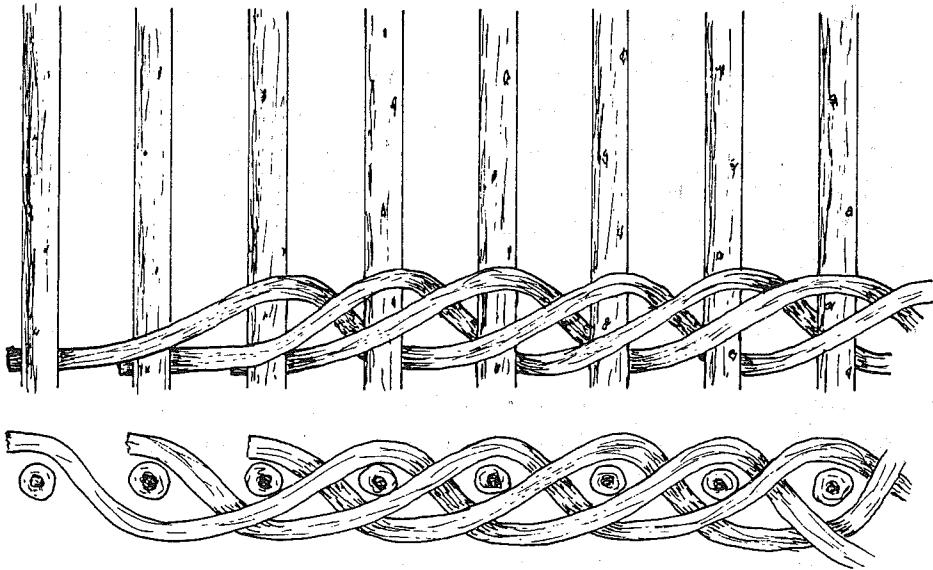

Figure 56. *Waling*, a technique which is widely applied to force passive strands in place (see figure 36 f and g).

tion and the method of shaping are recorded in the same block on the recording sheet, lies in the fact that an important part of the shape is determined by the often radical change in angle from base to side.

The range of variation is considerable. In some techniques, such as coiled basketry, the transition is done gradually, for instance by a change in stitching in the previous bundle. When the angle between base and side is more than 45° the stress on the material is in some cases too much and a solution to the problem has to be found by the basket maker. One solution is finishing off the base and then inserting new material for the sides at the angle desired.

The end of the base sometimes coincides with the end of the systems and a whole new technique is applied for the sides of the basket. This occurs for instance generally in sieves, because for sieves the 'base' has to be open trail work. The sides, however, need to have more strength than the open trail technique can provide. A special structure which is involved widely in the transition from the base to the side of stake-and-strand baskets is known in basket makers' terminology as 'waling'. A number of strands is worked around the stakes (see Figure 56), thus spacing out the stakes evenly.²² It is a preparation for the start of the basic structure at the side.

2.2.5 *Rim, edge* (see Figure 48)

The rim of a basket, or the edge of a mat, has a double function: it is both the end of the elements which form the basic structure and the border of the entire object. The techniques forming the rim therefore have to safeguard the coherency of the object and the strength of the rim itself, since the object and its contents are often lifted by the rim, or by handles that are anchored in the rim. Figures 57 and 58 illustrate two schematical drawings of rims.

2.2.6 *Other* (see Figure 48)

Here remarks can be made on techniques that do not fit the entries on technique in block 2 of the recording sheet. Examples are those techniques that do not start at the centre of the base. The entry offers just enough space to make a general remark on the technique and has a reference to a white page which can be used to add some drawings and a more extensive description.

²² The active element thus consists of a number of members, usually three or four, which in general follow an over 2 / under 1 / shift 1 pattern (three members), or an over 3 / under 1 / shift 1 pattern (in case of four members, see Figure 52).

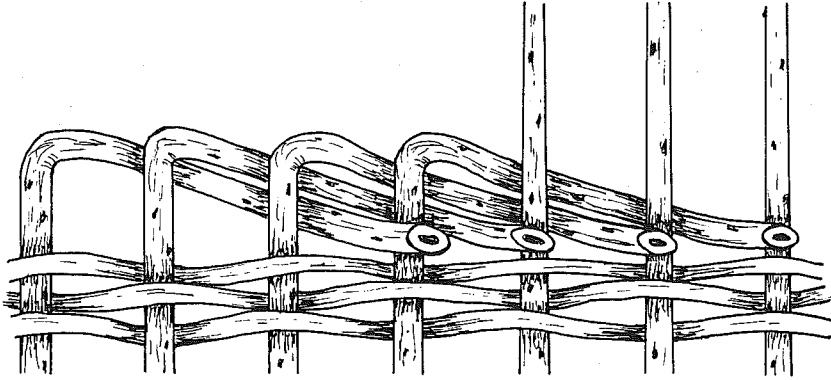

Figure 57. Example of a rim, as found on baskets with a set of passive elements. Here the passive stakes are fixed behind each other and then cut off.

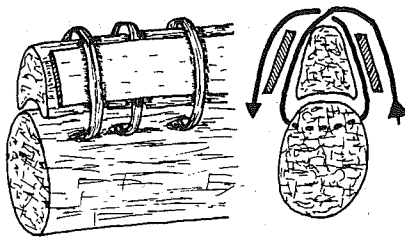
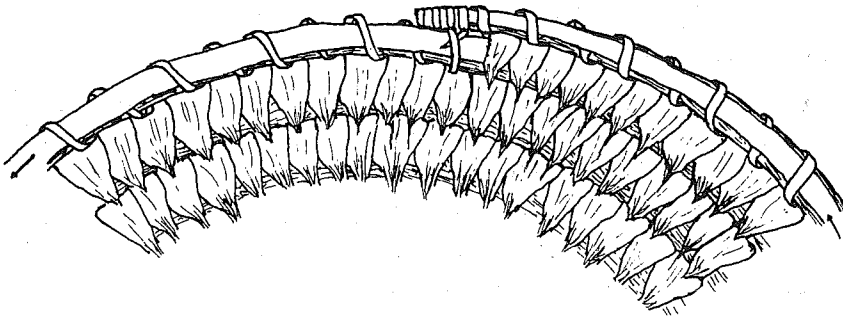

Figure 58. Example of a rim, as found on baskets with one passive element. The passive coil becomes thinner in the last round. Two strips of additional material have been applied, together with decorative stitching, to strengthen the rim.

3. Dimensions

3.1 Cordage (see Figure 59)

Cordage is measured with a tape measure and calipers, the latter being used for measuring all intervals below 100 mm. All dimensions are recorded in millimeters, estimates are noted down in brackets.

| 3 DIMENSIONS (in mm.) | NETTING |
|-----------------------|-------------------------|
| length: | maximum dimensions LxW: |
| diameter cable: | mesh size: + + + |
| diameter string: | mesh circumference: |
| diameter yarn: | opening: |
| | other dimensions: |

Figure 59. The section of the cordage and netting recording sheet which deals with dimensions.

length:

The only length which has to be measured for every cord is the total length of the stretched-out cord. When there are knots, the length of material that is incorporated in those knots is not included. An estimate of the total length (length of the rope plus the length needed to make the knots) can be noted down in brackets. Knotted constructions which involve more than one cord are measured as follows: after it has been determined which ends belong to the same rope, the lengths of the different ropes are measured, again without calculating the lengths needed for the knots. In respect to netting, an estimate of the total length of rope which would have been needed to make the net can be recorded here. This has to be noted down between brackets, to indicate that it is an estimate, and a specifying remark should be added to make clear which length exactly is indicated.

diameter cable:

diameter string:

diameter yarn:

Yarn, string and cable refer to three successive processes of spinning, plying and cabling. In a cabled rope the diameter can be measured at all three levels, in a rope that has not been cabled, just the diameter of yarn and string can be recorded. For spun yarns only the third line has to be filled in. Rope is sometimes squashed, especially when the fibres have shrunk. In such case only two measures

are recorded: the width and the height. An estimate of the original diameter, with correction for the shrinkage, may be added in brackets.

NETTING

maximum dimensions L x W:

Additional information is recorded for netting. The diameter of the yarn or string out of which the net is knotted is recorded on the left side of the block under 'diameter yarn' or 'diameter string'. The maximum length and width of the net is recorded on the right hand side.

mesh size: + + +

Almost every net has a mesh with four sides (see Figure 60A), which are all recorded. The mesh sides have to be measured at several spots in the net in order to determine the regularity of the net.

mesh circumference:

The circumference of the mesh is the sum of the lengths of the sides (usually four: $a + b + c + d$ in Figure 60A). Since the maximum diagonal (MD) is defined as half the circumference, it is not necessary to record the MD separately (Figure 60B).

opening:

What we really want to know is the *opening* of the mesh, in order to determine the size of fish or birds for which the net was designed. The opening (O in Figure 60C) is the diameter of a circle with the circumference of the mesh. It equals $a + b + c + d / \pi$ (3,142).

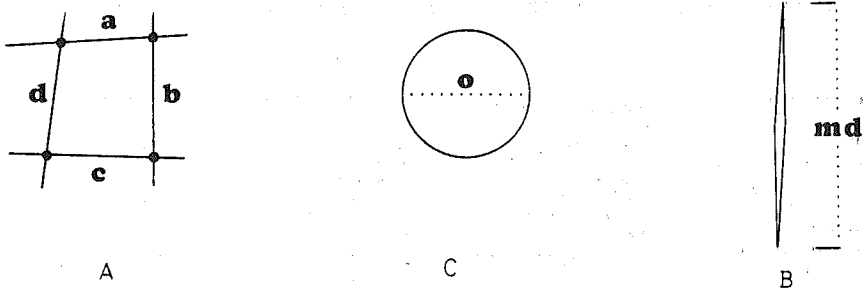

Figure 60. a. The circumference of the mesh is the sum of the sides of a mesh (usually four: $a + b + c + d$). b. Half the circumference is the maximum diameter (md). c. The *opening* (o) of the mesh is the diameter of an imaginary circle with the same diameter as the mesh: $a + b + c + d / \pi$ (3,142).

other dimensions:

In this entry any other relevant information on the dimensions of the object, such as the size of knots, or the length of a selvedge, can be recorded.

3.2 Basketry (see Figure 61)

The entries on basketry dimensions are divided in three parts: first of all information on the size of the object or fragment, secondly, information on the size of elements, the raw material and the space between the elements of the different systems, and thirdly on 'other dimensions'. Because the material is often hardly prepared, baskets often are not completely regular. Therefore either averages are used or special mention is made of the irregularities. All dimensions are measured at the outside of the object. All dimensions are recorded in millimeters, estimates being noted down in brackets. The tools for measuring are both tape measures and calipers, the latter being used for all distances less than 100 mm.

OBJECT

maximum dimensions LxWxH:

X X

The maximum length, width (diameter) and height of the basket are measured. For two-dimensional objects such as mats, only the length and width are recorded. Fragments are measured also. If the size of the original complete object can be reconstructed, these numbers are noted down in brackets behind the present size.

average thickness:

The thickness of a mat, or the thickness of the walls of a basket, is determined by measuring the object (sides and, if possible, the base) at three spots. The result of the three measurements is then middled in order to account for irregularities in the thickness. When (part of) the side and the base are made in a different

| | | | |
|--|--|--|--|
| 3 DIMENSIONS (in mm.) OBJECT maximum dimensions LxWxH: X X average thickness: maximum circumference: minimum circumference: diameter base: circumference base: diameter rim: circumference rim: | ELEMENTS AND RAW MATERIAL | | |
| | system 1: length elements: diam./width elements: space between elements: length material: diam./width material: other: | system 2: length elements: diam./width elements: space between elements: length material: diam./width material: other: | system 3: length elements: diam./width elements: space between elements: length material: diam./width material: other: |
| | OTHER DIMENSIONS | | |

Figure 61. The section of the basketry recording sheet which deals with dimensions.

technique or from different material, the measurements are recorded separately for each different part of the object. In that case the measurements have to be specified.

maximum circumference:

minimum circumference:

The circumference is measured at two spots, namely the spot where the basket has the largest and the smallest circumference. When the shape of the basket is distorted, the maximum and minimum circumference is measured and a reconstruction of the original circumference is noted down in brackets.

diameter base:

In the case of round baskets the diameter is recorded, plus any irregularities. For oval baskets two diameters are noted down: the maximum and minimum diameter. Square and rectangular baskets are measured at the middle of the straight sides and not along the diagonal. For rectangular - as for oval - baskets two numbers are recorded.

circumference base:

The circumference of the base is not necessarily the minimum circumference, as may be clear from a comparison of Figure 64 a and b (page 93). In the first drawing the circumference of the rim (4) is the maximum (1), and the circumference of the base (3) the minimum (2). In Figure 64b, four different values are recorded for the different circumferences. Estimates of the original circumference of an incomplete base can be noted down in brackets.

diameter rim:

For the diameter of the rim the same rules apply as for the diameter of the base.

circumference rim:

The circumference of the rim is not necessarily the maximum circumference. Estimates of the circumference of an incomplete rim (for instance with the help of a pottery rim sector gauge) are given in brackets.

ELEMENTS AND RAW MATERIAL

system 1 (2, 3)

The size of the elements and the raw material making up the elements is recorded in three blocks (for three separate systems).

length elements:

diam./width elements:

The size of the individual elements of the different systems is measured. The elements may consist of a number of leaves, twigs or stems, but are considered as one. Thus a coiled bundle of grass, for instance, is recorded under *element*, the length being the total length of the coil, the diameter being the diameter of the bundle.

space between elements:

The space between several elements of one system varies from closely fitted to widely spaced. This variety in spacing has to be recorded as is shown in Figure 62. System 1 is a passive system with a set of closely fitted elements, namely six grass bundles (space between elements of system 1: 0-1mm²³). System 2 is an active system, which consists of a set of widely spaced elements. All elements consist of two members twined in an S-direction (see Figure 36 d). The spacing between the elements is not identical, but there is a pattern: from top to bottom two elements are closely fitted, the third element is placed at some distance, the fourth and fifth elements are closely fitted, the sixth element is positioned at a distance (space between elements of system 2: 0-1 / 45 / 45). The number of times that the pattern is repeated is noted down (e.g. 0-1 / 45 / 45 : 6x) When the pattern is not clear, or the spacing is very irregular, all distances have to be measured and recorded.

length material:

diam./width material:

The dimensions of the raw material are recorded separately. In case the elements consist of one stem or twig, the average length and width of the raw material is identical to the dimensions recorded above under *elements*. Often, however, a number of leaves, stems or fibres are incorporated in one element, for instance a passive system consisting of a bundle of grass stems. It will not always be possible to measure exactly the length, width and thickness (diameter) of the material, since the stems, leaves or fibres are often incorporated in bundles, or interlacing patterns. Estimates are placed in brackets, guesstimates in double brackets (and so on). The shape of raw materials is often asymmetrical. In the case of a willow rod with a thin top and a thick butt, for instance, the two most divergent diameters are recorded.

²³ The space between closely fitted elements is not recorded as '0 mm' unless the weave is extremely regular and there is no space left at all. Usually some space is left between close fitting elements. This is expressed by the 0-1 mm entry.

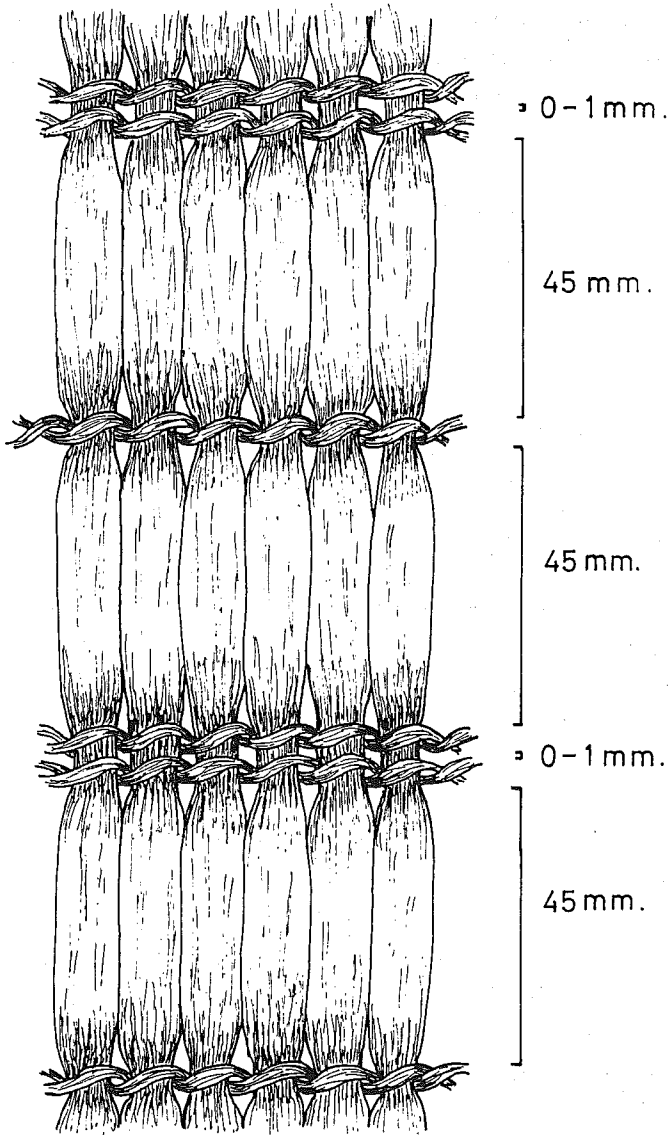

Figure 62. Measuring the space between the elements of both systems. The space between the passive elements is 0-1 mm. The space between the active elements varies, but at regular intervals the same pattern occurs (0-1 mm / 45 mm / 45 mm after which the pattern repeats).

other dimensions:

This entry provides space for dimensions that are not included in the standard sheet. A technique may exist of more than the three systems which the recording sheet caters for. The shape of a basket may require more measurements. When the shape of a basket is very complicated it is advisable to make a drawing (preferably to scale) in which the dimensions are indicated.

4. Shape (see Figure 63)

The shape is recorded by a general indication of the shape and a drawing to scale.

base: round / oval / square / rectangular / triangular / other:

side: round / oval / square / rectangular / triangular / other:

rim : round / oval / square / rectangular / triangular / other:

The shape of the cross-section of the base, side and rim is recorded by encircling the right answer. If the original shape is not evident, because only a fragment of the basket survives or due to distortion of the shape, this has to be indicated by circling the answer with a dotted line. The shape of mats is indicated under 'base'.

4 SHAPE (drawing to scale: side view with transverse section; bird's eye view)

base: round / oval / square / rectangular / triangular / other:
 side: round / oval / square / rectangular / triangular / other:
 rim : round / oval / square / rectangular / triangular / other:

see page ...

Figure 63. The section of the basketry recording sheet which deals with the shape of the objects.

drawing to scale: side view with transverse section / bird's-eye view (see Figure 64).

As with pottery, basketry is drawn half in transverse section, half from the outside. In this way the thickness of the walls can be indicated, as well as decoration on the inside and outside of the basket. In cases where the side view does not give enough information, as is for instance the case with flat objects such as mats or plates, a viewpoint from above the object is chosen. Again there is the problem

what to do with fragments or incomplete baskets. If a reconstruction of the shape can be made, the reconstruction should be drawn here, indicating clearly which parts are available, and which have been reconstructed. For small objects and fragments a scale of 1:1 is preferable. The block includes a reference to a separate recording sheet on which a larger drawing can be made.

Basketry Recording Sheet Page 2

The identification number is repeated at the top of the page.

5. Special features (see Figure 65)

Special features are those aspects which have been applied separately after the main body of the basket was completed. Included are also the unintentional additions to the basket, made when the object was being used. The features which occur are marked by ticking where appropriate. The space at the right is used for a description and drawing of the special features. The special features are divided in deliberately applied aspects, and things that have been added unintentionally.

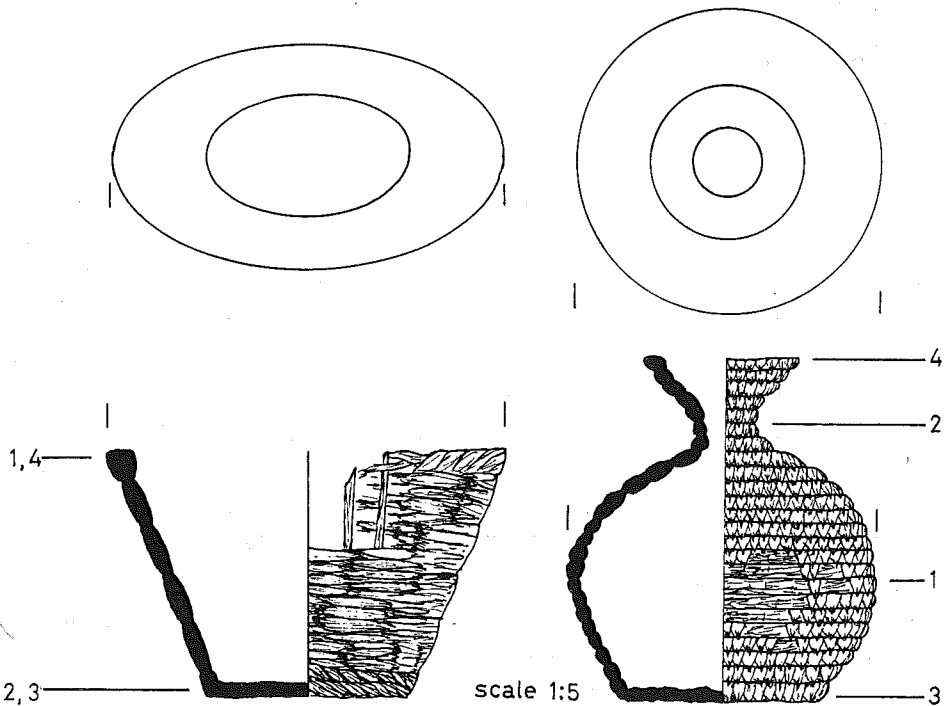

Figure 64. Two examples of drawings to scale of the shape. Indicated in the drawing are: 1 = maximum circumference; 2 = minimum circumference; 3 = circumference base; 4 = circumference rim.

| Basketry Recording Sheet | | page 2 | ID number: <input type="text"/> 2 |
|--|--|----------------------|-----------------------------------|
| 5 SPECIAL FEATURES | | description/drawing: | |
| Deliberate | Indeliberate | | |
| handles <input type="checkbox"/> | irregularities <input type="checkbox"/> | | |
| cover/lid <input type="checkbox"/> | stains <input type="checkbox"/> | | |
| foot <input type="checkbox"/> | wear <input type="checkbox"/> | | |
| colour <input type="checkbox"/> | secondary finds <input type="checkbox"/> | | |
| decoration <input type="checkbox"/> | | | |
| application <input type="checkbox"/> | | | |
| strengthening <input type="checkbox"/> | other <input type="checkbox"/> | | |
| repair <input type="checkbox"/> | | | |
| re-use <input type="checkbox"/> | | | |

see page ...

Figure 65. The section in which additional technical details are recorded.

Deliberate:

handles

cover

foot

When the base, sides and rim of a basket are completed, a number of features can be added. These are indicated as 'special features'. These include the handles (see Figure 66). This is not always the case, however. In a technique known as frame or ribbed basketry (see Figure 67 and Wright 1983:117-125) the handle is integrated in the basic structure. In such a case it will be indicated here that a handle is present, but the recording is incorporated in the block on technique (see section 2.2, page 48).

The cover, or lid, often is a separate basket in itself, which is, therefore, best described on a separate recording sheet or on an extra page added to the recording sheet. This block is meant for recording that a cover is present and in what way lid and basket are connected. The foot of a basket is often made by turning the finished basket around and inserting new material at the bottom side of the base. When the foot is an integral part, made at the start of the basket, however, it is described in block 2 (**TECHNIQUE, BASE**, page 72). With the exception of the first three features, handles, cover and foot, the basketry and cordage recording sheets are identical.

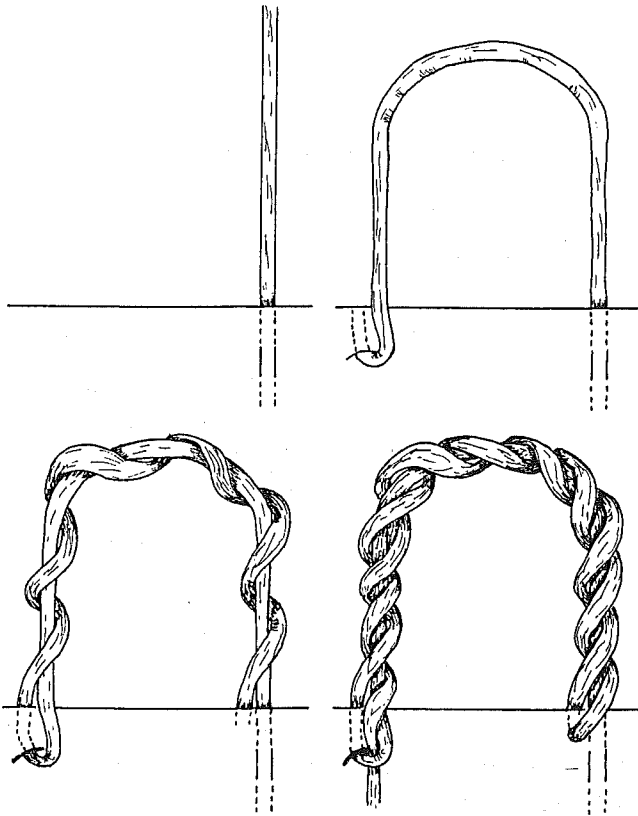

Figure 66. Reconstruction of the production sequence of a handle in four stages. In this way the structure of the handle is made clear, phase after phase.

colour

decoration

application

The application of colour and decoration partly overlaps. By marking the appropriate boxes it is indicated that a basket is decorated with coloured elements or by other means. Examples of these are decorative stitching or the application of additional materials such as feathers or beads. Recording of decorative patterns can be done by taking colour slides, but this is not sufficient. In order to determine exactly how the decoration is incorporated in the technique, drawings are imperative. The patterning of the decoration can give information on the meaning of a basket.

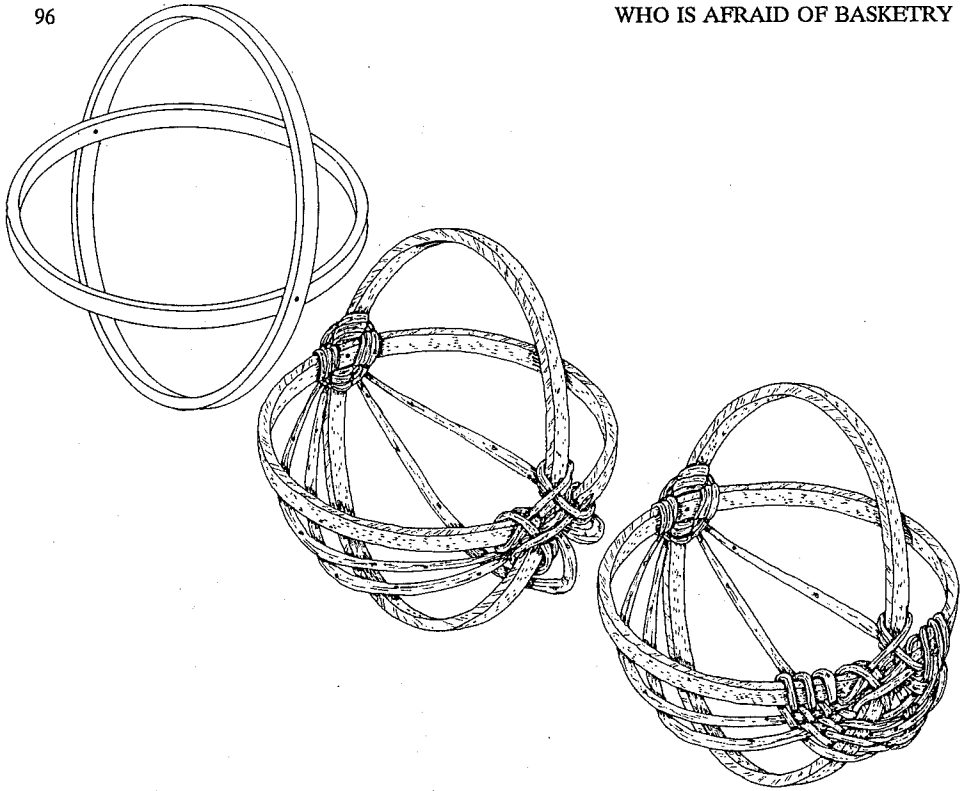

Figure 67. *Ribbed or framed basketry*: the basket is built around two ovals or circles. In the second stage the passive elements (*ribs*) are inserted. In the last stage the active elements are woven through the ribs, holding them in position.

strengthening repair

Strengthening can either be applied during the production process or afterwards, when a basket has been worn by intensive use. The difference has to be inferred from the way the strengthening is fixed. An example of the first is often visible at the rim: if extra material is inserted and the rim has thus a broader function than finishing off the elements of the side, we may assume that it has been strengthened. This means of strengthening is recorded in the **TECHNIQUE**-block (see page 84). In the entry under Special features, attention is drawn to the fact that the rim was strengthened. The same applies for strengthening of the base or the side. Inserting a round of waling is for instance a method of strengthening the sides of a stake-and-strand basket. Often it is difficult to distinguish strengthening from decoration, because a change in the pattern of the basic structure, even when applied for technical purposes only, can be very decorative.

from decoration, because a change in the pattern of the basic structure, even when applied for technical purposes only, can be very decorative.

The second case, strengthening at a later stage, is in many cases synonymous with repair. Repair is everything from tying together two ends of a broken handle, or a minimal strengthening of slightly worn parts up to the renewal of considerable parts of the basket. The way the repairs have been executed should be recorded in detail.

re-use

Re-use is the use of a basket for a purpose for which it was not originally designed. The rim of a basket may be re-used as a pot stand; two badly damaged baskets may be put together, the one inside the other, to cover each others holes. A decision on re-use is an interpretation from the context in which the object is found. For anthropologists there is always the possibility to ask whether a basket is meant to be used in the way it is found. Archaeologists have to figure it out for themselves (and may be wrong).

Indeliberate:

irregularities

Irregularities are 'mistakes' which were made during the production of the object. Such mistakes are often valuable because they give clues for a reconstruction of the production process.

stains

wear

secondary finds

These three features give information on the use of a basket. All stains that are found on the object have to be recorded and if possible sampled. On archaeological sites it cannot be completely excluded that the stains are modern jam, but in principle the stains are either the effect of ancient use or of (post-) depositional processes. The wear patterns are best recorded by making a schematical drawing of the object on which the wear is indicated. Ideally wear is studied by scanning electron microscope, but of course this is an expensive technique which demands specialised knowledge.²⁴

A secondary find is everything that is not part of the basket, but is connected with the object in one way or another. A bird's feather which clings to an open

²⁴ An example of the study of wear in archaeological textiles by means of an SEM can be found in Cooke 1987.

trail work basket, remains of grain, mud which is stuck to the outside of a basket, are all secondary finds. Judging whether these finds have anything to do with the original contents (and thus with the function) of the basket is something that often has to be postponed until a later phase (analysis). Important is that all information about the object is available.

other

This category can be used to indicate additional features, deliberately or unintentionally caused, which are not accounted for in the categories listed above.

6. Material (see Figure 68)

The raw material of which the object has been made is recorded in this block. Often this part of the recording sheet will have to be filled in later, since fibre identification can only be performed in a reasonably well equipped laboratory (see Chapter Six, section 2). The block is divided into two parts, the left side indicating which method was used to obtain the information, which is recorded in the block on the right.

method:

In this block is indicated on what basis the material has been analysed.

macroscopical view

In the field it is often impossible to say anything more than that an object is made of 'grass' or 'rods'. From previous experience a remark can be added that the grass is "probably *Desmostachya bipinnata*" and that the rods are "probably a *Salix* species", both nothing more can be stated until the fibre identification has been performed. Since often a selection has to be made on the objects that can be sampled for identification (see Chapter Six), such an indication still has some use.

microscopical examination, magnification X

light microscope / stereo microscope / metallographic microscope / Scanning Electron Microscope:

cross section / longitudinal section / epidermis

photo:

The method used for microscopical examination has to be recorded; this includes the magnification (e.g. x 600, x 1000), the type of microscope used and the way the sample was prepared. A separate entry lists the micro-photographs which were taken.

| | |
|--|--|
| <p>6 MATERIAL</p> | <p>all systems separate (stakes, strands, bundle, winders, etc.) latin name and local name</p> |
| <p>method:</p> | <p>system 1: sample Y/N</p> |
| <p><input type="checkbox"/> macroscopical view</p> | <p>system 2: sample Y/N</p> |
| <p><input type="checkbox"/> microscopical examination, magnification X</p> | <p>system 3: sample Y/N</p> |
| <p>light microscope / stereo micr. / metallographic micr. / SEM</p> | <p>other:</p> |
| <p>cross section / longitudinal section / epidermis</p> | <p>reason for sampling: common/exceptional</p> |
| <p><input type="checkbox"/> other</p> | |

Figure 68. The section in which information on the raw material is incorporated.

The cordage sheet differs from the basketry sheet, in that the specification of microscope and type of analysis has to be filled in, rather than circled.

other

Apart from those indicated above, other methods can be used (e.g. macerating).

all systems separate (stakes, strands, bundle, winders, etc.)

When the systems, as identified in the block on basic structure, are made of different materials, all systems have to be sampled.

latin name and local name

For each material the Latin name and the local name should be noted down (the Latin name usually not known until the fibre identification has been performed).

system 1 sample Y/N

system 2 sample Y/N

system 3 sample Y/N

other:

The systems in this entry are the ones that have been defined in the block on technique under 'BASIC STRUCTURE'. Whether or not a sample is taken should be recorded for each systems. The entry 'other' is meant for basketry which is made with more than three systems.

reason for sampling: common/exceptional

It is important for the final analysis to indicate why a certain sample is taken. A general reason is the fact that the material is common or exceptional (of course as far as this can be judged on a macroscopical level). In this block an indication may be given of the reasons for preparation of the raw material before being used by the basket maker. Retting, beating or combing of plant parts is done in order to destroy the soft cells, and thus to isolate the strong fibre cells.

7. *Condition* (see Figure 69)

waterlogged / moist / dry

First of all it is indicated if the object is waterlogged, moist or dry at the moment of investigation.

| | | |
|--|--------------|---------|
| 7 CONDITION waterlogged / moist / dry general impression: fibre: coherency: | description: | colour: |
|--|--------------|---------|

Figure 69. The section which deals with the recording of the condition of the object at the moment of investigation.

general impression

fibre

coherency

Then the condition of the object is indicated briefly by noting down ++, +, +-, - or --. This is done at all three entries listed above. The condition is dependent on the condition of the fibre and the coherency of the object.

description

colour

In two blocks a brief description of the condition and of the colour are given. In describing the colour it is very important to be consistent. One solution is using a colour chart, e.g. the Munsell Soil Colour Chart. Even though this chart is not designed for basketry it gives at least a standard. Another - and a lot cheaper - possibility is to obtain colour sample strips from your local paint shop. The range of colours of this home made chart is limited, but sufficient. Most important is that the consistency is better guaranteed this way, than with variable descriptions such as 'reddish brown' or 'brownish red'.

8. *Treatment* (see Figure 70)

cleaning

conservation

reversing agent

This section provides a description of the cleaning and conservation methods which have been applied to this particular object (see Chapter Seven). If the consolidation is reversible, the reversing agent should also be mentioned.

date

When the subsequent treatments are dated, it is possible to check the effect of the treatment on the condition of the object, even after a long period.

| | | | | | |
|----------------------------------|--------------|-------------------------|--------------|---------------|--------------|
| <p>8 TREATMENT cleaning:</p> | <p>date:</p> | <p>conservation:</p> | <p>date:</p> | <p>other:</p> | <p>date:</p> |
| | | <p>reversing agent:</p> | | | |

Figure 70. The recording section on cleaning and conservation.

other

This entry is meant to include all other treatments that an object has had. Especially the application of poisonous fumes or liquids have to be indicated clearly as a warning for everybody who will be handling the objects in the future.

9. Storage (see Figure 71)

The entry 'storage' refers to the way the object is packed (see Chapter Seven). The number of the box in which the object is stored should also be mentioned. The 'present location object' indicates, as detailed as possible, the exact position of the object, including the museum, the store room, and even the position on the shelf.

| | | |
|------------------|-----------------|---------------------------------|
| <p>9 STORAGE</p> | <p>storage:</p> | <p>present location object:</p> |
|------------------|-----------------|---------------------------------|

Figure 71. The section recording as to where and how the object is stored.

The 'present location object' indicates, as detailed as possible, the exact position of the object, including the museum, the store room, and even the position on the shelf.

10. Context (see Figure 72)

This entry is possibly the most important of all. Without this entry, the object does not have any real meaning. Recording an object in detail is not a purpose in itself. The information is only valuable when it is used to pronounce upon the society in

10 CONTEXT site information / history

see page ...

Figure 72. The section in which either a description of the archaeological context, or a brief description of the provenance of the ethnographical material is recorded.

which the object has functioned. For archaeological artefacts the precise position on site has to be recorded. It is not sufficient to copy a row of numbers, however. A description of the layer, unit or locus should be given as well. Mention of other find categories from the same context which provide information on dating, function etc. also can be included. Ethnological basketry can be nested in an even broader context, which includes information on the social structure of the basket makers' village, or the economical distribution of basketry in a region. Of course such subjects are extensive studies, which cannot be included in this entry.

11. Use (see Figure 73)

As has been indicated above (page 25), the use to which an artefact was put is not something that can be 'read' directly from the object. Since ideas about the possible function of an object often occur while studying every detail, the recording stage is a suitable moment to write down suggestions about the use. One has to keep in mind, however, that this block gives information of a different level: we are not dealing with data but with inferences.

11 USE

see page ...

Figure 73. Inferences on use of the artefacts are noted down in this section.

12 REMARKS

Figure 74. A section for additional remarks on any aspect of the objects.

12. Remarks (see Figure 74)

The entry for remarks provides space for any suggestions that arise during the examination of the artefacts. References and cross-references to comparable objects and related finds (e.g. awls, bodkins, needles, knives, rapping irons) can be included.

13. Two more recording sheets

For some objects, such as brushes or wreaths, the basketry recording sheet is a bad fit. In order to keep some consistency in the recording method and at the same time avoiding making separate sheets for a number of special cases, an alternative page 1 is included (see Figure 75). This sheet includes the same block 1 (IDENTIFICATION), but the rest of the page is a simple version of the basketry sheet. The block on technique includes only the entries on recording the systems of the basic structure. The dimensions cover the measurements of the main aspects. The shape is only recorded by drawing. With the understanding of the recording method for basketry, the miscellaneous objects can be recorded along the same principles. The second page is the same for basketry and miscellaneous objects.

Basketry Recording Sheet Miscellaneous page 1

| | | |
|--|--|---|
| 1 IDENTIFICATION site/museum: number: date: researcher: | photo archive black&white: slides: | ID number: <input style="width: 80px;" type="text"/> 1 description: complete/greater part/fragment/other way of preservation: |
|--|--|---|

2 TECHNIQUE

no. of systems [] _____
 System 1
 one element/set of elements
 active/passive
 no. of members [] S/Z/I
 preparatory work:
 none [] corded [] plaited []
 other: _____

System 2
 one element/set of elements
 active/passive
 no. of members [] S/Z/I
 preparatory work:
 none [] corded [] plaited []
 other: _____

System 3
 one element/set of elements
 active/passive
 no. of members [] S/Z/I
 preparatory work:
 none [] corded [] plaited []
 other: _____

see page ...

| | | | | |
|--|---|--|--|---|
| 3 DIMENSIONS (in mm.) OBJECT maximum dimensions LxWxH: X X average thickness: maximum circumference: minimum circumference: | MATERIAL system 1 length: diameter/LxW: other: | system 2 length: diameter/LxW: other: | system 3 length: diameter/LxW: other: | SPACE system 1: system 2: system 3: other: |
| OTHER DIMENSIONS: | | | | |

4 SHAPE (drawing to scale: side view with transverse section; bird's eye view)

see page ...

Figure 75. A separate sheet (page 1) for recording artefacts made of vegetable fibres, in basketry - related techniques. The second page is identical to the basketry recording sheet, page 2.

Basketry Recording Sheet

page . . .

ID number:

...

Figure 76. The header of the additional page which can be inserted when the space on the sections of the recording sheets is not sufficient.

On the recording sheet, regular reference is made to page ... (see Figure 76). This is an empty page, provided with a box for the identification number of the object and a cross reference to the block on the previous sheet (re...) for which the extra page is a continuation. The number of pages which can be added to the recording of one basket is thus *ad lib*.

... ..

... ..

CHAPTER SIX

SAMPLING

1. Introduction

The archaeologist or ethnographer working in the field will often be confronted with a large amount of basketry. Recording such quantities in detail will rarely be possible. In such cases it will be necessary to make a sample. Sampling is the making of a collection for a certain purpose. A collection may be made in order to preserve a representative group of baskets. A sample may also be based on technical or material criteria. Such criteria are generally determined by the original objective of research, and thus sampling should be regarded as an important aspect of the analysis.

Another form of sampling is the collection of material for identificatory purposes, for instance to determine its age, the raw material used, or the treatment it was given. This type of sampling is destructive; consequently, the objects should be recorded as fully as possible, before the sample is being processed.

The first rule in taking such samples is that sampling should be performed before any consolidant is applied, since the resins might render the samples useless for certain types of analysis. Especially radiocarbon dating is very sensitive to recent contaminations. In some cases, however, preservational measures might be needed to keep the sample in as good a condition as possible until it can be examined. The rules outlined in Chapter Four and Seven apply to the preservation of samples, but it should be noted that no formaline or consolidants should be applied. In order to preserve wet samples, only clean water may be added.

Taking a sample of a basket might mean damaging the object. Preferably those parts of the basket are taken which are badly connected or have come off. A loose fragment can only be taken as a sample if it is beyond reasonable doubt that the fragment comes from the particular object, or set of objects, that has to be identified. If a sample has to be cut from the object, an already damaged spot should be chosen where the fibres are already loose. Taking a sample should not

weaken the object.¹ The cutting should be done with razor sharp scissors or scalpel knives to make clear at which point the sample was taken² and in order to disturb the basket as little as possible. When dealing with complete objects, for instance in museum collections, it has to be considered how important the information is that will be retrieved from the sample. When the information is vital, then gathering the information may be regarded more important than keeping the object intact. Mostly, however, the choice will be made not to damage the artefact.

Often the taking of samples is bound to strict rules, either by museum staff or even by governments. Explicit permission has to be obtained before taking a sample. This permission often requires correspondence or filling in numerous forms, so extra time has to be calculated for this.

Two types of sample collections will be considered in more detail below: sampling for fibre identification and for dating.

2. *Fibre identification*

What and why

The choice as to which objects have to be sampled for fibre identification precedes the actual sampling. Fibre identification cannot be performed for every object within a large collection. The main reason for sampling is often the identification of material from a few 'special' objects. Secondly all macroscopically 'special' looking material can be identified to provide some idea of the range of material used. A third reason for sampling is providing a broad general view of the raw material applied. The sampling for this type of research is best performed by statistical methods. The recording sheet should indicate the purpose of the sampling.

How

Fibre identification can be performed in different ways. When the material is in good condition the epidermis structure can be studied or a cross or longitudinal section can be made. When the material is in a bad condition the fibres can be

¹ This is true in general. Exceptions to this rule might have to be made, when the research question demands a sample being taken which is destructive to the object. For every individual case the pro's and cons of the procedure will have to be weighed.

² When it is not made clear from which part of the object a sample has been taken, the modern sampling might at a later stage be interpreted as ancient traces of use.

macerated. Since the plant epidermis shows considerable variation, depending on which part of the plant is studied, it is important to make a deliberate choice which part is sampled for epidermis identification. If the plant parts are still recognisable, it should be stated on the recording sheet from which part the sample is taken. Preferably a short description should be given, such as 'base of the stem', 'leaf sheath', 'top part of the leaf'. Epidermis identification can of course only be performed on material on which the epidermis is left. This is all material which is worked up in its original form, without having had a preparatory treatment, such as peeling or retting. In general the material has to be in good condition.

When no epidermis is available, as is the case with damaged or specially prepared material, there are still other means of identification. Fibres such as flax are retted in order to remove the weak parts and keep the long fibre cells. Individual fibre cells can be mounted as a whole. For material which consists of more cell layers a thin section has to be made. This can be either a cross or a longitudinal section. Sections can be made from stems, roots and leaves which are in reasonable condition.

For badly deteriorated material the only possibility that remains is to macerate the plant parts. Maceration is the destruction of the coherency of the plant cells by soaking and boiling the plant remains. The isolated cells are then studied under the microscope.

All samples should be stored in small plastic bags, with a clear label from which object they are taken. Samples of different systems involved in the basket (for instance samples from the passive and active system) have to be packed in different bags on which the original system is clearly indicated.

How much

The amount of material that is needed for fibre identification depends on which type of identification will be performed. For epidermis identification of material that is in good condition a very small sample (2cm^2) will suffice. When the epidermis is damaged a substantial larger fragment has to be sampled. For thin sections a fragment of 5 cm length is required. For maceration a fragment of 2 cm is enough.

All methods of fibre identification are destructive, except the study of the epidermis under a metallurgic microscope or a Scanning Electron Microscope.

3. Dating

What and why

The reason for sampling basketry for dating purposes is either because the basketry can be used as dating material for the archaeological context, or as a means of identifying the age of a certain basket type. The selection which object to sample is therefore dependent on either findspot or typology. The first choice can be made by the site supervisor. The second choice, however, is again dependent on the questions posed in the analysis and requires the help of a basketry specialist. One clear indication for sampling is for instance a technique which does not correspond to the dating of the archaeological context by other artefact classes.

How

Radiocarbon dating is a method which is suitable for dating basketry and cordage. The method is based on the diminution of the level of radio activity of carbon 14 in organic material. The part of the basket from which the sample is taken is of no consequence. More important is the treatment of the basket and the sample, because modern carbon pollutes the samples and renders the results unreliable. Therefore special care should be taken to avoid pollution of the samples. First of all the specimen should not be treated with any consolidant. Secondly the sample should be taken with clean metal instruments (scissors or a sharp knife). A sample that has been polluted, for instance when it has fallen on the ground, or has been touched by hand, has to be discarded. In the third place the packing material can contaminate the sample. Organic packing material, such as cotton wool, card board, and tissue paper should be avoided, using glass tubes, plastic bags, or aluminium foil instead. For the same reason labels should not be included with the samples, but attached firmly to the exterior of the container (Aitken 1990: 85-89; Michels 1973:163-164; Mook and Waterbolk 1985:33).³

How much

The amount of material needed to do radiocarbon dating is dependent mainly on the kind of facilities available in the laboratory. In the case of wood, the

³ A second dating method which in some cases can be used for basketry is dendrochronology. Forms of basketry which have been made of wood of considerable age, can be dated by the variation in size of tree rings, caused by fluctuation in annual growth under varying circumstances (Aitken:36-50). For this type of dating the choice of the part which is sampled is of course of the utmost importance. A cross section is needed for comparing the tree rings.

conventional method of radiocarbon dating needs 10-20 grams dry material from originally dry wood and 40-80 grams of dry material from originally wet wood.

An advanced facility, indicated by Aitken as 'Minicounter', needs by far smaller samples: 0.5 - 1 grams dry material from originally dry wood and 1-2 gram dry material from originally wet wood. The method of Accelerator Mass Spectrometry (AMS) may do with samples which are a factor 10 smaller: 0.05 - 0.1 grams and 0.1 - 0.2 grams respectively (Aitken 1990:91).

These figures are minimum quantities of sample material. If more material can be sampled without seriously damaging the object, a larger quantity is preferable.



CHAPTER SEVEN

PRESERVATION AND STORAGE

1. Introduction

Although recording ethnographical and archaeological basketry in detail can be considered a means of preservation, it is in many cases important not only to secure the survival of knowledge, but also that of the actual artefacts. Recently acquired ethnographical material is usually in good condition. The maintainance of modern and antique basketry is a matter of proper storage conditions and regular checks on insect activity. The term *passive conservation* indicates what has to be done: preventing the objects from deteriorating by bringing them in absolutely stable conditions, with the right temperature and the right relative humidity. The basics for passive conservation can be found in section 6 (page 120).

Passive conservation is sometimes not sufficient for objects of the recent past, and especially for archaeological material. In that case more radical measures may have to be taken in the form of (active) conservation. Great risks are involved in conservation, however, since the effect of the measures often cannot be predicted. In the end the protective treatment may even prove to expedite the total destruction of the object.

Since conservation by the untrained frequently does more damage than good, a specialised conservator should be involved. This chapter is, therefore, only an introduction to basketry preservation and gives an indication of the measures which can be taken in the field.

Conservation is the responsibility of the excavator, that is, the person or institution that caused the change in circumstances of objects which survived for hundreds of years before being brought to light. Therefore, a conservation budget ought to be part of the excavation budget.

In Chapter Four the first 'rule' was to keep all excavated objects as much as possible in the same state in which it was found: waterlogged basketry was to be kept wet, dry basketry was to remain dry. The secondary treatment, which ideally takes place in a laboratory, is meant to bring all objects into the same condition:

dry and stable. Conservation thus consists of a number of actions which range from cleaning and restoring the shape via consolidating to packing and storage.

2. *Cleaning*

Ideally cleaning is performed after examination and recording, since the cleaning may damage the object. Often, however, the dirt makes it impossible to properly examine the object. Sometimes it is advisable to refrain from cleaning altogether, because the dirt is the only thing that provides any coherency to the object. A difference should be made between dirt and 'secondary elements' such as remains of the original contents of the basket and stains which could indicate how it was used. Ideally basketry is cleaned with pH-neutral water,¹ but often this is not feasible, field work being synonymous with improvisation.

Waterlogged material

If a basketry specialist is available, then the cleaning of basketry can start on site, simultaneously with recording the object. If the staff is not trained to deal with the specific artefact group, the specimen should be lifted with the surrounding soil. Examining and cleaning are then performed in the laboratory. During this entire period the object should be kept wet.

Cleaning of waterlogged basketry should be done in wet conditions, by rinsing the specimen carefully in a large quantity of water. Ideally the basketry is cleaned under water by means of ultrasonic waves. Only well-equipped laboratories, however, offer this possibility. A field alternative is cleaning the basketry with jets of water from a small submerged hosepipe. Only very soft paint brushes can be applied. The use of brushes is hazardous, because brushing may damage either the epidermis of the material, leaving traces on the surface, or cause fibres to fall off. Tweezers and surgical pins serve well in removing the harder traces of dirt.

Dry material

Dry material can be cleaned mechanically with brushes, surgical pins, and tweezers. A low power vacuum cleaner is to be preferred over tools that blow air because the latter only move dirt, rather than removing it. Sometimes it might prove necessary to apply moist cleaning, for instance when a hard mud layer cannot be removed without damaging the epidermis. In general the object should

¹ Litmus paper is used for testing the acidity of water. See Chapter Two.

be in very good condition to do this. Soaking dry basketry is not advisable. It is better to re-humidify the object (see below) and then to brush the specimen with moist brushes, letting it dry thoroughly afterwards.

3. Restoring shape

The shape of archaeological material is often distorted. In the case of wet basketry, the shape can be restored by supporting the object in the right position while it is drying. But before leaving an object to dry, it is important that a decision is made on the method of consolidation, since some resins are preferably applied when the material is still wet, while others can be applied after drying. Drying is done either slow, in controlled circumstances, or extremely fast by freeze drying.

Dry basketry and cordage should never be forced into its former shape. This will certainly damage the material. The only solution is a process of very slow humidification in a bell chamber (see Figure 77). This usually takes at least three to five days, depending on the size of the object. The object can then gradually be

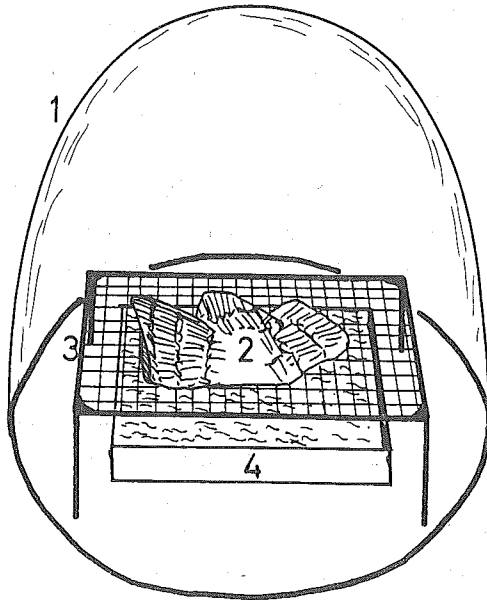

Figure 77. A bell chamber: a glass airtight chamber (1) contains the object (2), which is placed on a grid (3). The evaporation of the cold water which is placed in a container under the grid (4) causes the slow rehumidification of the object.

positioned into its former shape over a period of several days, while still in the bell chamber. After that, the object should be allowed to dry slowly for a number of days, its shape being supported by acid free tissue paper. Bell chambers, however, usually are not widely available in the field. A site bell chamber can be made by suspending a piece of wire netting, the size of the specimen, over a basin, containing a shallow layer of cold water. The object is then put on top of the wire netting and a big sheet of polythene is shaped around it, closing it off completely.

Fine netting can be treated as textiles. After humidifying the specimen with a spray bottle it can be mounted on mosquito netting and soaked in a basin of water. Afterwards the net, which is usually entangled, can be layed out, fixing the corners of the mesh with pins.

4. Consolidation

Consolidation is a specific form of conservation, namely the application of a consolidant in order to strengthen the fibre structure of the objects. The principle of a consolidant is that it consists of at least two components: a resin and a solvent which acts as a vehicle for the resin. Consolidation has the objective of arresting the decay of an object. Even more drastic measures, such as restoration, or copying an object, are not discussed within the scope of this book. Other means of conservation will be discussed in sections 5 and 6.

Which objects should be consolidated?

Consolidation techniques are expensive and time consuming. In practice, this means that not every object can be given the proper treatment, and a selection has to be made. In museums and ethnographic collections, the condition of the objects is generally fairly good. The decision on the number and scope of objects that are to be consolidated, is often dictated by the collection as a whole. In archaeological excavations, however, the decision on what to consolidate is often a choice between survival of an object or its collapse, the condition of the artefacts being in general quite bad. The basis on which the decision is taken which objects to keep and which objects to loose is the importance of the object in the total collection. It is difficult to give a general definition of the importance of basketry. Both general and unique specimens qualify for preservation. A suitable example of a general type of artefact should certainly be preserved, but baskets and cordage in which some aspects, such as technique, shape or function are unique in relation to the period or the region in which they were found, also qualify for treatment.

Consolidating processes

When discussing the condition of basketry we should make a distinction between the fibres and the object as a whole. In the first place the fibre cells might have collapsed, secondly the coherency of the object can be bad because of damage or wear. Of course a combination of both problems does occur as well. In the past, both problems have been treated by applying a consolidant. In fact, consolidation is only suitable for solving the problem of a bad inner structure. For the 'outer structure', the coherency of the object, preferably other methods should be used, since applying a consolidant would result in total plastification of the entire object. The structural coherency can be restored either by repair or by (partial) restoration. Another method to deal with the problem of bad coherency is to design specially adapted packing, which keeps every part of the object in a fixed position (see section 5).

Several problems arising in the application of consolidants, have to be considered here. In the first place, the solvent, which is the vehicle for the resin, may cause the failure of the whole process. In principle, the solvent penetrates the plant cells, evaporates and leaves the resin behind. Thus the resin strengthens the fibre structure and the coherency at a basic level. In practice the problem with consolidation is that the resin has to penetrate deeply into the object and not just into the outer layers. The application of different layers of resin not necessarily has this effect, since the solvent might dissolve the resin and transport it back to the surface where the solvent evaporates and a concentration of the resin is left behind.

Another problem is that many consolidants cause a certain stiffness, which is unlike the natural flexibility of basketry materials. The surface of the objects often becomes darker and sometimes even glossy.

In general there is no ideal resin available. In many cases the long term effect is not known and when a resin is not reversible it might in the end have the opposite effect to the purpose desired.

Every object selected for conservation treatment has to be recorded first, by the filling in of recording sheets, photographs and drawings. Thus the information about the object is recorded, even if conservation fails. Samples should be taken before any consolidant is applied, since the resin renders the samples useless, for, among other things, radio carbon dating.

Basketry from wet, waterlogged and permafrost sites

The basketry, after being cleaned in wet condition, has to be dried. The major problem with drying waterlogged basketry and cordage is shrinkage, which might seriously damage the object. Tests with freeze drying on related material have varying results (e.g. De Jong 1975). The consolidation can be applied when the specimen is still wet or the basket can be dried first and a consolidating agent applied afterwards. The advantage of the last mentioned method is that it can be decided at the last possible moment whether consolidation is really necessary. Furthermore, the effect of drying will be visible and can partly be corrected. The disadvantage is that it is impossible to totally submerge the objects into a consolidating liquid when dry. Only the application of the liquid on the surface, either by spraying or with brushes, is left open. Consolidation when the object is still wet can be performed either by spraying the diluted consolidant over the object during a long period, or by bringing the objects in a series of baths in which the concentration of the consolidating resin is increased. The water in the cells is thus slowly exchanged with the consolidating resin. The advantage of these methods is that the consolidants penetrate the object deeper and have a positive effect on the drying process.

It may be clear that none of these methods is ideal for all circumstances. The decision which method to apply depends on the condition of the object. This is a matter of judgement which can only be made by an experienced conservator.

Basketry from dry sites

Dry basketry cannot be submerged into a consolidating resin. The sudden pressure on the fibres would cause the collapse of the cell structure. Even re-humidified basketry should not be treated this way. The only possible method is the application of the consolidant with brushes. Impregnation in this way is difficult. In order to prevent the accumulation of resin in the outer layers, the evaporation of the solvent can be slowed down by covering the material with plastic sheets directly after the solution has been applied.

First aid conservation

Although conservation is a specialised line of work, it is in some cases necessary that a field archaeologist or a basketry specialist performs first aid conservation. When it is obvious that an object will not survive the transport to the laboratory, or even the time necessary for recording or retrieval from site, it might be decided to consolidate either the object, or both object and surrounding soil. First of all samples should be taken before applying any consolidant. The consolidant is best

applied either by spraying, which is especially suitable for wet and waterlogged basketry, or with brushes. In the latter case, a number of layers should be applied. Appendix C gives a list of consolidants, used for basketry. If the object is to be conserved properly after the recording is finished, the consolidant should be reversible.² It is important that the consolidant applied is indicated clearly on a label, attached to the object.

5. Packing

Consolidation is useful when the fibre structure is in a deteriorated condition, but the object itself still has at least some of its coherency. Conservation of the structure of the basket cannot be carried out by the application of a resin. To improve the coherency, all parts of the object should be fixed individually, for instance with Cyano acrylate glue. A possibility which does not involve chemicals is fixing the object in polythene by vacuum sealing. The vacuum pulls the polythene tightly around the object, thus supporting it at all sides. This method is only suitable for very dry material, since the tightly sealed polythene might create a micro climate. It is vital to check objects packed like this regularly. Other solutions for maintaining the coherency of an object is making a pre-shaped packing in which the object is nested. Here conservation and storage meet.

For basketry and cordage which is in good condition the rules for packing are not complicated. In the first place, the surrounding should be free of acidity, secondly, the objects need to be supported, and thirdly, clinging material should be avoided. This means that basketry and cordage are best stored in acid free tissue paper or acid free bags, such as the ones used by stamp collectors. Since the use of newspapers should be avoided, because they are preservational time bombs, even in the most difficult site circumstances, it is best to bring acid free tissue paper. It is not only used as packing material, but also for support and stuffing. Materials such as mosquito netting and cotton wool are best avoided. When stored for longer periods special attention should be paid to the way the basketry is supported. In museums it may be decided to make more permanent

² The application of a 'first aid' consolidant makes proper conservation more complicated, since the temporary resin should be removed before the final treatment can start. This implies an extra treatment, which is always a risk. Thus a decision to apply first aid conservation might prove in the end more hazardous for the artefact than refraining from any treatment.

supports in order to make the baskets accessible for study without them having to be handled (see Griset 1986).

Packing materials present realistic dangers to basketry. Some types of wood have a high acidity, innocent looking materials such as polystyrene foam release fumes such as hydrochloric acid. Basketry is preferably stored in acid free cardboard boxes (Kühn 1981).

6. Storage

Storage is a conservative job, in two senses of the word. In the first place the aim of storage is the conservation of the objects, secondly, the way this is done is conservative in the sense that all circumstances are to be kept the same as much as possible. Fluctuations in temperature and relative humidity³ are most harmful to basketry and cordage. Such changes stress the cells into breaking down because of swelling and shrinking. Furthermore, deviations of the ideal temperature and relative humidity can cause explosions of mould and insect activity. A stable temperature of 18-20°C and a relative humidity of 50-55% are the safest condition for the storage of basketry and cordage. Basketry which does not come from an archaeological context is in fact better kept by a relative humidity which is slightly higher (62%), the only problem being that with a higher relative humidity the chance of mould growth increases.

7. Mould and Insects

Fungal spores are everywhere, but at a RH below 55% they cannot turn active. After a temporary rise in the RH (80-92%) the spores can germinate. Once the spores are active they can maintain themselves by a low RH. Fungi need a certain ratio of carbon and nitrogen to feed on. A clean basketry fragment might not be attractive, but the combination of basketry and stains or food remains might prove an ideal nutrient. It is therefore advisable to clean the basketry thoroughly, handle the objects with gloves and in general keep the storage clean and free of food. The same can be said for insects. Their metabolism might find in stains just the missing quantity of nitrogen, needed to digest the basketry.

³ Relative humidity (RH) is the ratio between the quantity of water present in the air and the maximum quantity of water that the air can contain at that temperature.

Good housekeeping is essential to keep mould and insects out of the storage space. If they are already present more severe measures have to be taken. The range of bactericides, fungicides, insecticides and rodenticides is wide (Roelofs 1986). Since these products are also poisonous for human beings, it is necessary to involve a specialist who can advise on these matters. In field situations this is often not possible and the only solution is to use locally available preparations.

A method which can be applied in the field is to impregnate sheets of blotting paper with the biocide and after thorough drying, include these in the boxes. In all cases it is vital to separate the basketry and cordage from the blotting paper by a thick layer of tissue paper, since the effect of the biocides on the material is not known.

8. Labelling

A vital part of storage is the precise labelling of every object. For the archaeological record an object, however complete, is nonexistent if the label is lost. Therefore, the labels should be attached both to the object, if this is possible without damaging it, and to the container in which the object is stored. Attaching labels to basketry can be done by using existing spaces in the weave, with the help of a smyrna needle. If the labels cannot be attached to the object itself, only one object has to be stored in a box and a label has to be put both inside and on the outside of the box. The labels are best written with water resistant permanent ink. They should contain all the numbers which once have been given to the object. Furthermore, the conservational treatment that has been given to the basket and any protective measurements against mould and insects should be clearly mentioned on the labels.

APPENDIX A

EXAMPLES OF RECORDING SHEETS

This section presents examples of filled-in recording sheets for three objects. The first item is a small basketry plate from the excavation of the Egypt Exploration Society at Qasr Ibrim (Egypt). The plate is recorded on three sheets: the standard two basketry sheets and an extra page. The other two items derive from the excavations of the University of Delaware at Abu Sha'ar (Egypt). They are two netting fragments and a piece of rope. They are recorded on a cordage/netting recording sheet.

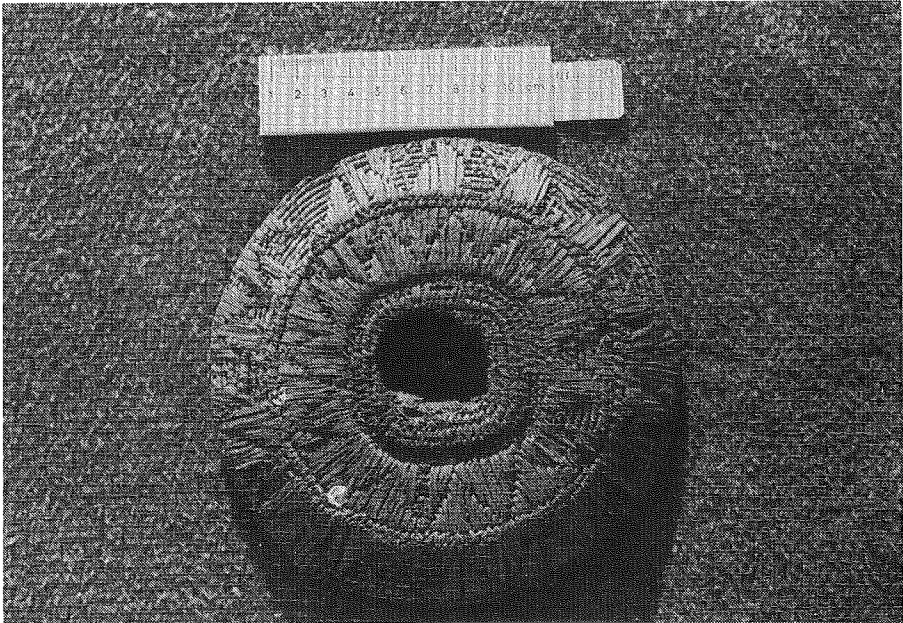

Plate 19. Basketry plate from Qasr Ibrim, Egypt (4th century A.D). Courtesy to the Egypt Exploration Society

Basketry Recording Sheet

page 1

| | | |
|---|---|--|
| <p>1 IDENTIFICATION</p> <p>site/museum: <u>Qasr Ibrim</u></p> <p>number: <u>10.121</u></p> <p>date: <u>21-1-1990</u></p> <p>researcher: <u>W.Z. Wendrich</u></p> | <p>photo archive</p> <p>black&white: <u>12-8A</u></p> <p>slides: <u>Q190 69, 70, 71, 72</u></p> | <p>ID number: QI 068 1</p> <p>description: <u>Circular plate, decorated with stitches</u></p> <p>complete/greater part/fragment/other way of preservation:</p> |
|---|---|--|

| | | |
|---|--|---|
| <p>2 TECHNIQUE</p> <p style="text-align: center;">BASIC STRUCTURE</p> <p>no. of systems [<u>2</u>]</p> <p>System 1</p> <p>one element/set of elements</p> <p>active/passive</p> <p>no. of members [<u>1</u>] S/Z/I</p> <p>preparatory work:</p> <p>none <input type="checkbox"/> corded <input type="checkbox"/> plaited <input type="checkbox"/></p> <p>other:</p> <hr/> <p>System 2</p> <p>one element/set of elements</p> <p>active/passive</p> <p>no. of members [<u>1</u>] S/Z/I</p> <p>preparatory work:</p> <p>none <input type="checkbox"/> corded <input type="checkbox"/> plaited <input type="checkbox"/></p> <p>other:</p> <hr/> <p>System 3</p> <p>one element/set of elements</p> <p>active/passive</p> <p>no. of members [<u>1</u>] S/Z/I</p> <p>preparatory work:</p> <p>none <input type="checkbox"/> corded <input type="checkbox"/> plaited <input type="checkbox"/></p> <p>other:</p> | <p>BASE</p> <p>see SHAPE</p> <p>scheme of centre:</p> <p>3. missing</p> <p>2. winding 'a' 3 rows</p> <p>3. winding 'b' 3 rows</p> <p>4. winding 'a' 1 row</p> <p>5. decorative wrapping 9 rows</p> <p>6. winding 'a' 1 row</p> <p>orientation inside base: <u>e</u></p> <p>continuation (scheme):</p> <p style="text-align: center;">see page 3</p> <p>active system [<u>2</u>] passive system [<u>1</u>]</p> <p>no. of elements: 1 no. of elements: 1</p> <p>no. of rows: no. of rows: min. 17 rows</p> <p>other systems (specify):</p> <p>increasing (scheme):</p> <p>6. closely wound coils</p> <p>10. partly open wound coils</p> <p style="text-align: right;">see page 3</p> | <p>SIDE scheme basic structure:</p> <p>see SHAPE</p> <p>7. decorative wrapping</p> <p style="text-align: center;">See page 3.</p> <p>orientation inside: e / reversed e</p> <p>active system [<u>2</u>] passive system [<u>1</u>]</p> <p>no. of elements: 1 no. of elements: 1</p> <p>no. of rows: no. of rows: 9</p> <p>other systems (specify):</p> <p>insertion/exhaustion:</p> <p>1. bundle: gradual insertion of palm leaf strips</p> <p>2. winder: not visible</p> |
| <p>plaited: system no. []</p> <p>no. of strands []</p> <p>under /over /shift</p> <p>PI:</p> <p>angle of plait:</p> <p>reg/irr.</p> <p>corded: system no. []</p> <p>sP[C]:</p> <p>Cl₁: ——— x100 =</p> <p>Cl₂: ——— x100 =</p> <p>Cl₃: ——— x100 =</p> <p>reg/irr.</p> <p>facings system: no. [<u>2</u>]</p> <p>rigid <input type="checkbox"/></p> <p>flexible <input type="checkbox"/></p> <p>semi-flexible <input type="checkbox"/></p> <p style="text-align: right;">see page ...</p> | <p>TRANSITION BASE-SIDE</p> <p>METHOD OF SHAPING</p> <p>description/drawing:</p> <p><u>Quick transition to shallow side in 7 stitches</u></p> | <p>RIM, EDGE description/drawing:</p> <p>see SHAPE</p> <p><u>8. winding 'a' 1 row</u></p> |
| <p>OTHER description/drawing:</p> <p style="text-align: right;">see page ...</p> | | |

| | | | | |
|---|---|---|---|---|
| <p>3 DIMENSIONS (in mm.)</p> <p>OBJECT</p> <p>maximum dimensions LxWxH:</p> <p><u>175 X 175 X 17.5</u></p> <p>average thickness: <u>6</u></p> <p>maximum circumference: <u>560</u></p> <p>minimum circumference: <u>405</u></p> <p>diameter base: <u>126</u></p> <p>circumference base: <u>405</u></p> <p>diameter rim: <u>175</u></p> <p>circumference rim: <u>560</u></p> | <p>ELEMENTS AND RAW MATERIAL</p> <table style="width:100%;"> <tr> <td style="width:33%;"> <p>system 1:</p> <p>length elements: [<u>1950</u>] ±</p> <p>diam./width elements: <u>3, 2</u></p> <p>space between elements: <u>0-1</u></p> <p>length material: [<u>650</u>]</p> <p>diam./width material: <u>1, 7</u></p> <p>other:</p> </td> <td style="width:33%;"> <p>system 2:</p> <p>length elements: ✓</p> <p>diam./width elements: <u>3 X 1</u></p> <p>space between elements: <u>0-3</u></p> <p>length material: <u>350</u></p> <p>diam./width material: <u>3</u></p> <p>other:</p> </td> <td style="width:33%;"> <p>system 3:</p> <p>length elements: ✓</p> <p>diam./width elements:</p> <p>space between elements:</p> <p>length material:</p> <p>diam./width material:</p> <p>other:</p> </td> </tr> </table> <p>OTHER DIMENSIONS:</p> | <p>system 1:</p> <p>length elements: [<u>1950</u>] ±</p> <p>diam./width elements: <u>3, 2</u></p> <p>space between elements: <u>0-1</u></p> <p>length material: [<u>650</u>]</p> <p>diam./width material: <u>1, 7</u></p> <p>other:</p> | <p>system 2:</p> <p>length elements: ✓</p> <p>diam./width elements: <u>3 X 1</u></p> <p>space between elements: <u>0-3</u></p> <p>length material: <u>350</u></p> <p>diam./width material: <u>3</u></p> <p>other:</p> | <p>system 3:</p> <p>length elements: ✓</p> <p>diam./width elements:</p> <p>space between elements:</p> <p>length material:</p> <p>diam./width material:</p> <p>other:</p> |
| <p>system 1:</p> <p>length elements: [<u>1950</u>] ±</p> <p>diam./width elements: <u>3, 2</u></p> <p>space between elements: <u>0-1</u></p> <p>length material: [<u>650</u>]</p> <p>diam./width material: <u>1, 7</u></p> <p>other:</p> | <p>system 2:</p> <p>length elements: ✓</p> <p>diam./width elements: <u>3 X 1</u></p> <p>space between elements: <u>0-3</u></p> <p>length material: <u>350</u></p> <p>diam./width material: <u>3</u></p> <p>other:</p> | <p>system 3:</p> <p>length elements: ✓</p> <p>diam./width elements:</p> <p>space between elements:</p> <p>length material:</p> <p>diam./width material:</p> <p>other:</p> | | |

4 SHAPE (drawing to scale: side view with transverse section; bird's eye view) base: round / oval / square / rectangular / triangular / other: _____

side: round / oval / square / rectangular / triangular / other: _____

rim: round / oval / square / rectangular / triangular / other: _____

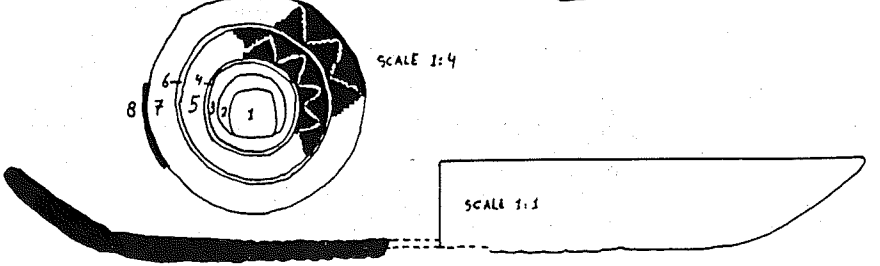

see page ...

Basketry Recording Sheet

page 2

ID number: QI 068 2

5 SPECIAL FEATURES

| Deliberate | Indeliberate |
|--|--|
| handles <input type="checkbox"/> | irregularities <input type="checkbox"/> |
| cover/lid <input type="checkbox"/> | stains <input type="checkbox"/> |
| foot <input type="checkbox"/> | wear <input type="checkbox"/> |
| colour <input checked="" type="checkbox"/> | secondary finds <input type="checkbox"/> |
| decoration <input checked="" type="checkbox"/> | other <input type="checkbox"/> |
| application <input type="checkbox"/> | |
| strengthening <input type="checkbox"/> | |
| repair <input type="checkbox"/> | |
| re-use <input type="checkbox"/> | |

description/drawing:

colours: orange and dark brown
decorative wrapping over winding 'a'

see page 3

6 MATERIAL

method:
 macroscopical view
 microscopical examination, magnification X 60
 light microscope / ~~stereo micr.~~ metallographic micr. / SEM
 cross section / longitudinal section / epidermis
 other

all systems separate (stakes, strands, bundle, winders, etc.)

latin name and local name

leaf cut in strips

system 1: *Hyphaene thebaica* sample ~~YN~~ dom palm

system 2: *Hyphaene thebaica* sample ~~YN~~ dom palm

system 3: sample Y/N

other:

reason for sampling:

common/exceptional

7 CONDITION

waterlogged / moist dry
 general impression: - +
 fibre: +-
 coherency: +

description:

centre and a considerable part of the
 wrappings missing. Quite good epidermis
 features left on winders (2) at the inside.

colour:

orange and dark brown
 (no dye analysis)

8 TREATMENT

cleaning: date:
 dry cleaning 21-1-'90
 moist cleaning 22-1-'90

conservation:

date:

other:

date:

reversing agent:

9 STORAGE

storage:

acid free tissue paper,
 basketry box 1

present location object:

store 2, shelf 3A

10 CONTEXT site information / history

section 10.121 late X-group
 ↳ see site log

house context ⇒ infill in room 3 crypt
 (dump of late X-group pottery)

see page ...

11 USE

probably use inside household, linked with food storage/
 presentation. Plate rather than cover.

see page ...

12 REMARKS

The missing centre was probably plaited (similar to 067)
 also: compare 141

ra. 2, 5, 12

winding 'a'
not to scale

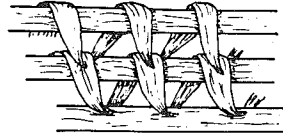
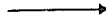

winding 'b'
not to scale

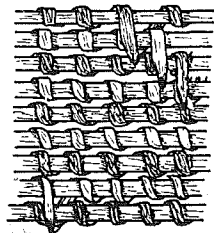
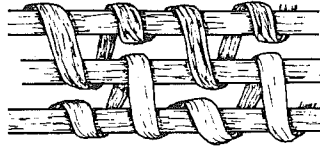

first level: winding without stitching, fustened by occasional stitch over two bundles (every 8 windings a stitch)
not to scale

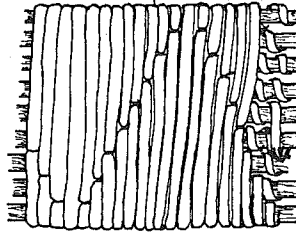

second level: wrapping over 9 bundles
not to scale



cross-section of wrapping
not to scale

centre probably:

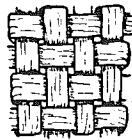

(reconstruction; not to scale)

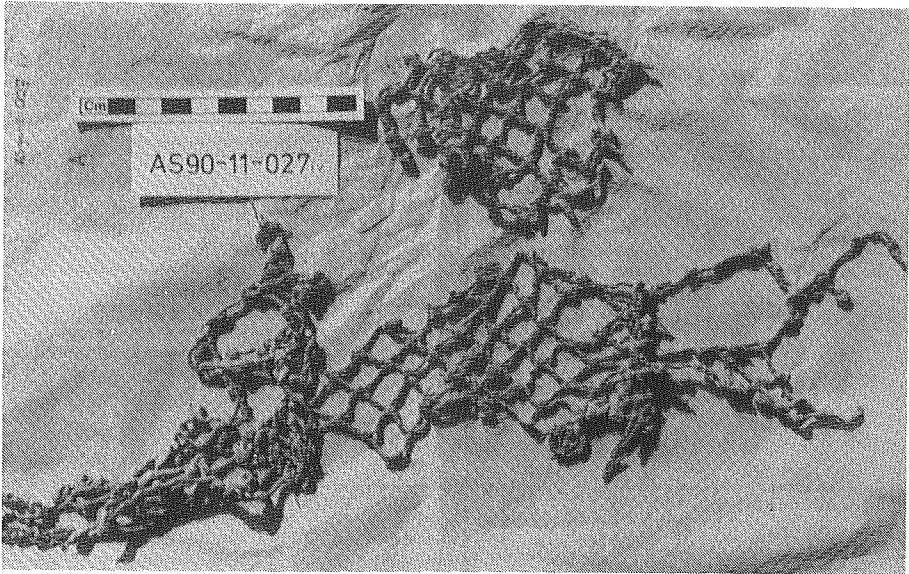
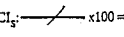
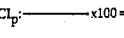

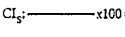

Plate 20. Netting fragments from Abu Sha'ar, Egypt (3rd - 4th centuries A.D.)



Plate 21. Cordage fragment from Abu Sha'ar, Egypt (3rd - 4th centuries A.D.)

| Cordage / Netting Recording Sheet page 1 | | 1 IDENTIFICATION | |
|---|--|---|--|
| description: 2 netting fragments ID number: AS90-11-27 1 site/museum: Abu Sha'ar H002 photo archive: iy date: 5-8-'90 PB 2 black&white: 17-32 researcher: WZW slides: - complete/greater part (fragment)/other way of preservation: | | description: cabled fragment ID number: AS90-11-27 1 site/museum: H002 PB2 photo archive: XV date: 5-8-'90 black&white: 18-31 researcher: W.Z.V. slides: - complete/greater part (fragment)/other way of preservation: | |
| 2 TECHNIQUE sP(C): z Spun plait: - other: - Cl ₁ :  x100 = irr. Cl _p :  x100 = Cl _c :  x100 = PI: too deteriorated to tell. description/drawing: | | 2 TECHNIQUE sP(C): z S ₂ S ₂ plait: - other: - Cl ₁ :  x100 = irr. Cl _p : $\frac{7 \times 2.5}{24.3} \times 100 = 72$ Cl _c : $\frac{8 \times 3.5}{55.9} \times 100 = 50$ PI: description/drawing: | |
| 3 DIMENSIONS (in mm.) length: NETTING 360 x 150 diameter cable: maximum dimensions LxW: 70 x 80 diameter string: mesh size: 10 + 10 + 10 + 10 diameter yarn: 1.7 mesh circumference: 40 opening: 12.7 other dimensions: | | 3 DIMENSIONS (in mm.) length: 80 diameter cable: 5.5 diameter string: 3.5 diameter yarn: 2.5 NETTING maximum dimensions LxW: mesh size: + + + mesh circumference: opening: other dimensions: | |
| 4 SHAPE (of no consequence) see page ... | | 4 SHAPE (of no consequence) see page ... | |
| 5 SPECIAL FEATURES colour <input type="checkbox"/> irregularities <input type="checkbox"/> decoration <input type="checkbox"/> stains <input type="checkbox"/> strengthening <input type="checkbox"/> wear <input type="checkbox"/> repair <input type="checkbox"/> secondary finds <input type="checkbox"/> re-use <input type="checkbox"/> other <input type="checkbox"/> description/drawing: see page ... | | 5 SPECIAL FEATURES colour <input type="checkbox"/> irregularities <input type="checkbox"/> doubling of decoration <input type="checkbox"/> stains <input type="checkbox"/> zS ₂ string strengthening <input type="checkbox"/> wear <input type="checkbox"/> to zS ₂ repair <input type="checkbox"/> secondary finds <input type="checkbox"/> cable re-use <input type="checkbox"/> other <input type="checkbox"/> description/drawing: see page ... | |
| 6 MATERIAL Linum ussita lissimum sample $\frac{1}{2}$ X common / exceptional | | 6 MATERIAL probably Desmostachya b. or Imperata c. sample $\frac{1}{2}$ X common / exceptional | |
| 7 CONDITION waterlogged / moist / dry general impression: - has been wet fibre: - coherency: + description: muddy / deteriorated colour: grey S | | 7 CONDITION waterlogged / moist / dry general impression: + fibre: + coherency: + description: brown 14 other: | |
| 8 TREATMENT date: 5-8-'90 cleaning: moistening / soaking then laid out to dry conservation: - reversing agent: - other: - | | 8 TREATMENT date: / cleaning: conservation: reversing agent: other: | |
| 9 STORAGE sewn to acid free tissue paper, box 2 present location object: unknown antiqu. store | | 9 STORAGE small bag box 2 present location object: unknown antiqu. store | |
| 10 CONTEXT trash dump H002 PB 2 3rd-4th cent. AD. see page ... | | 10 CONTEXT trash dump H002 PB 2 3rd-4th cent. AD see page ... | |
| 11 USE fish nets see page ... | | 11 USE no specific indication see page ... | |
| 12 REMARKS Check fish species Red Sea area see page ... | | 12 REMARKS zS ₂ S ₂ rather than zS ₄ since doubling of string is visible see page ... | |

APPENDIX B

PLAIT INDEX

In Chapter Five, section 2.2.1, the *Plait Index (PI)* was introduced as an indication of the angle of plait. The exact angle can be calculated from the ratio $\frac{n \times d}{1}$ (see page 68).¹

This operation requires a calculator with an inverse sinus mode. However, such a calculator is not always available. Moreover, due to irregularities which always occur in plaiting, the angle of plait does not require such precision. Therefore, the angle of plait can be assessed equally well from the *plait index* and Table 2 which gives the rounded angle of plait for PI is 40 up to 139.

| PI | 0 | 1 | 2 | 3 | 4 | 5 | 6 | 7 | 8 | 9 |
|-----|------------|------|------|------|------|------|------|------|------|------|
| 40 | 33° | 34° | 35° | 35° | 36° | 37° | 38° | 39° | 40° | 41° |
| 50 | 41° | 42° | 43° | 44° | 45° | 46° | 47° | 48° | 48° | 49° |
| 60 | 50° | 51° | 52° | 53° | 54° | 55° | 56° | 57° | 57° | 58° |
| 70 | 59° | 60° | 61° | 62° | 63° | 64° | 65° | 66° | 67° | 68° |
| 80 | 69° | 70° | 71° | 72° | 73° | 74° | 75° | 76° | 77° | 78° |
| 90 | 79° | 80° | 81° | 82° | 83° | 84° | 86° | 87° | 88° | 89° |
| 100 | 90° | 91° | 92° | 93° | 95° | 96° | 97° | 98° | 100° | 101° |
| 110 | 102° | 103° | 105° | 106° | 107° | 109° | 110° | 112° | 113° | 115° |
| 120 | 116° | 118° | 119° | 121° | 123° | 124° | 126° | 128° | 130° | 132° |
| 130 | 134° | 136° | 138° | 140° | 143° | 145° | 148° | 151° | 155° | 159° |

Table 2

¹ Since the *plait index* is calculated from half the angle at which the strands meet, the PI indicating an angle of 90° would be 0.70710. To obtain a more convenient number the sine is multiplied by 100/SIN 45° (= 141.42136).

The first part of the document discusses the importance of maintaining accurate records of all transactions. It emphasizes that proper bookkeeping is essential for the success of any business and for the protection of the interests of the owners and investors. The text outlines the various methods and systems used to record and summarize financial data, including the use of journals, ledgers, and trial balances. It also touches upon the significance of these records in providing a clear and concise picture of the company's financial performance over time.

The second part of the document delves into the specific details of the accounting process. It describes the flow of information from the initial recording of transactions to the final preparation of financial statements. This section covers the classification of transactions into assets, liabilities, and equity, and the use of double-entry bookkeeping to ensure that the accounting equation remains balanced. It also discusses the importance of adjusting entries to accurately reflect the economic reality of the business at the end of each accounting period. The text concludes by highlighting the role of the accountant in providing reliable and timely financial information to management and external stakeholders.

In conclusion, the document underscores the critical role of accounting in the modern business environment. It stresses that a strong foundation in accounting principles and practices is necessary for any individual or organization seeking to achieve long-term financial success. By adhering to the highest standards of accuracy and integrity, accountants can provide the valuable insights and information needed to make informed decisions and drive business growth.

APPENDIX C

CONSOLIDANTS

Although this is not a guide to field-conservation, I would still like to include a short list of consolidants, used for basketry and cordage. It should also be added that there is no 'ideal' basketry consolidant known as yet. The resins either darken the appearance or cause an unnatural stiffness of the object.:

Cyano Acrylate glue

The so-called 3-seconds glue is reversible (dissolves in acetone or an ammonia solution). It is very useful in the restoration of basketry objects.

Soluble nylon

A white powder, sold under the name of Catalon which has to be dissolved in ethyl alcohol and water at a temperature of minimal 40°C. The material is hard to dissolve and is only used as a temporary consolidation (maximum three days), because it is irreversible after some time.

Paraloid B72

Paraloid is a polybutylacrylate, which is sold in the form of granules which are to be dissolved in acetone (4-15%). It causes only a slight darkening of the colour, and no gloss. The basketry loses its flexibility, and in some cases even becomes quite brittle. The process is said to be reversible.

PEG

Poly Ethylene Glycol is a synthetic wax which is for sale in several degrees of molecular weight. The lower the number, the lower the melting point of the PEG.

PEG 400: Shaffer uses a mixture of 25 g. PEG 400 and 20 g. glycerine dissolved in a 3.5:1 ethylalcohol/water solution in order to improve the hygroscopy of the basketry (Shaffer 1976:4). From a point of view of consolidation, PEG 400, which has a melting point of 20°C, seems not very useful.

PEG 1000

PEG 1500: Adovasio uses 10-20% of PEG 1000 and 1500 dissolved in water (Adovasio 1977:12) to consolidate dry and brittle specimens. For wet basketry a series of baths can be used in which the percentage increases from 10 to 100. *46° melting point*

PEG 4000: Dowman uses PEG 4000 on dry wood. The PEG is melted (melting point 60°) and used undiluted when still warm (Dowman 1970:137). The formula she gives for insect infested wood can be applied for basketry when using PEG 1500 rather than PEG 4000:

10 parts by weight PEG 1500

1 part by weight formaline

69 parts by weight ethanol 95%

20 parts by weight distilled water

In general PEG seems to be satisfactory for wet basketry. Application on dry basketry gives problems with respect to the penetration. The procedure is reversible.

Poly-urythane

A polymere which can be thinned with ethyl-acetate (xylene). The advantage is that the specimen remains flexible. The disadvantages are that the application is irreversible and that the object darkens quite badly.

PVA

Poly Vinyl Acetate can be dissolved in toluene, alcohol or acetone. It gives the material a darker appearance and is glossy when used in higher concentrations. A 10 or 20% solution can be used for consolidation. Solutions of 30% and higher are used as a wood glue. PVA used to be widely applied but is no longer used for basketry, because of the change in appearance it causes. The process is reversible.

PVC

Poly Vinyl Chloride, is for sale commercially with a specific solvent under the name of ArcheoDerm. Although the specimen only turns slightly darker and shows no gloss, the consolidant has certain drawbacks, in that it causes the basketry to lose its flexibility. The process is said to be reversible.

APPENDIX D

USING PLAIT-O-METRIC PAPER

In general, the use of a grid makes drawing easier. Representations of plaits, or weaves, for that matter, indicating not only the strands, but also the space in between the strands, are often better understandable than drawings in which the space is omitted. For this purpose a sheet of graph paper which is rotated at an angle of 45° and contains separate lines to indicate the space between strands, has been included in this book. This plait-o-metric paper can be used, for instance, under drawing film. Figure 80 illustrates how a plait is drawn, using the graph paper.

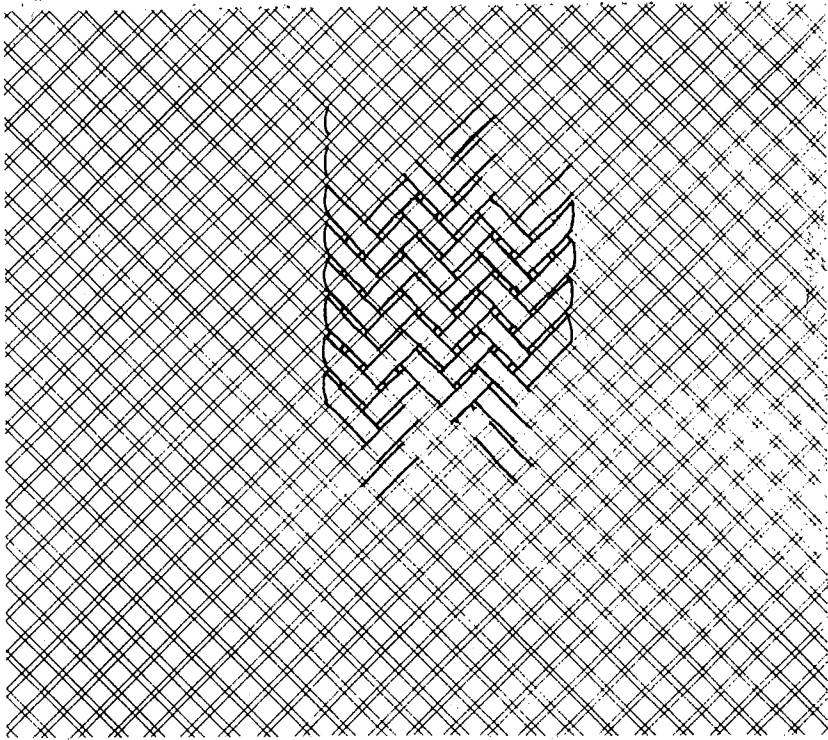

Fig. 80. Drawing plaits on special paper.

...the ... of ...
...the ... of ...
...the ... of ...

...the ... of ...
...the ... of ...
...the ... of ...

...the ... of ...
...the ... of ...
...the ... of ...

...the ... of ...
...the ... of ...
...the ... of ...

...the ... of ...
...the ... of ...
...the ... of ...

...the ... of ...
...the ... of ...
...the ... of ...

GLOSSARY

active: those strands which create the coherency of a basketry technique. See: passive

angle of plait: the angle at which the strands of a plait meet. The angle can be measured directly from the object, with a protractor. It is preferable, however, to calculate the *plait index (PI)*, and assess the angle from this. See: plait index

aspect: an aspect is a variable property of an object, such as its length, diameter, colour, raw material, or decoration. Consequently the technical structure can be described as a collection of aspects, such as the number of systems, number of elements, orientation and activity. The variations which occur in a certain aspect, are indicated as attributes. The aspect material, has, for instance, the attributes grass, willow and hemp. The determination of both aspects and attributes are dependent on the research question. See: attribute, dimension

attribute: attributes are the different varieties of an aspect: 10 cm, 20 cm and 30 cm are attributes of the aspect 'length'. Brown, green, yellow, are attributes of the aspect 'colour'. See: aspect, dimension

basic structure: this is the way in which a technique is made up of several strands. The basic structure consists of a number of systems. The systems each consist of an element or a set of elements that have the same role in the technique. The interaction of the systems result in a coherent structure which makes up the technique (page 48). See: system, element, technique

bell chamber: an airtight glass container, which derives its name from the fact that it is bell-shaped. The bell chamber is used for slow re-humidification of basketry in order to restore its original shape (see page 115)

bend: a knot which connects two different lengths of string. See: knot, knob knot, hitch, splice

bight: the active part in the middle of a rope, incorporated in knotting. See: standing part, working end

bodkin: small pointed awl.

border: the edge at which the strands are fastened off. Ssee: selvedge, rim, edge

bow knot: a knot comparable to the reef or granny knot, in which the ends are not pulled through entirely, so that two loops remain (Figure 78). See: reef knot, granny knot

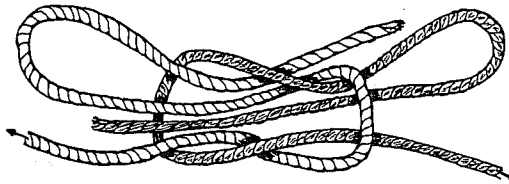

Figure 78. Bow-knot

bundle: the passive element in coiled basketry, also indicated as 'foundation'. See: foundation, winder, coiled basketry

butt: the thick end of a (willow) rod. See: top

cable (n): two or more strings turned around each other in order to form a strand. See: cable (v), string, yarn, rope.

cable (v): the turning of two or more strings or ropes around each other in order to form a strand, referred to as cable. See: cable (n)

coiled basketry: a technique which involves two systems: a passive system, consisting of one element (bundle, foundation) which is coiled and held into place by an

active element (winder), which follows the coil. This technique is also known as 'beehive-technique', 'stitched basketry' or 'sewn basketry'. See: bundle, foundation, winder

cord: general term for plied, cabled, round-plaited or knotted strands. See: string, cable, plait, sinnet

cordage: a class of artefacts consisting of vegetable fibres, which have been worked into long cylindrical strands, of, theoretically, unlimited length, as well as artefacts obtained by knotting such strands.

cord index (CI): the cord index is number in between 0 and 100 and expresses the speed, or tightness, with which yarns have been spun, strings have been plied and cables have been cabled. For a cabled rope the cord index can be calculated on three levels: CI_s for the spin, CI_p for the ply and CI_c for the cable. For measuring and calculating the CI, see pp. 37-38 and Figure 13.

crossing: see Figure 15, p. 40

crowning: continuous knotting of crown knots in three or more strands (see Figure 11).

dimension: the term *dimension* is used in two different ways. In Chapter Five, section 1, it is synonymous with 'aspect', to indicate the complexity of a classification, according to the number of aspects involved. See: aspect, attribute; In Chapter Five, section 3, the term *dimension* is used to indicate size, or measurements.

element: part of a system which makes up the basic structure of a basket (see page 54-56). See: system, basic structure

edge: the edge of a basket or mat can either be a border (the line at which the strands are fastened off) or a selvedge (a line at which the strands continue, but the edge of the object is formed by a radical change in orientation of the strands). see: border, selvedge. A second use of the term *edge* is an equivalent for the term *rim* (of containers) in describing the shape of flat objects, such as mats. See: rim

English randing: a basic structure (stake-and-strand) in which one element (rod) is used at a time to weave one round. The next rod is inserted between the next two stakes (Plate 17, Figure 54). See: French randing, stake-and-strand, rod, stake

epidermis identification: a method of fibre identification in which the structure of the uppermost layer of the leaf, stem, root or leaf sheath is used as the identificatory aspect. The magnification needed is at least 600x. When studied under a metallic microscope, this method is non-destructive for the sample; for study under a light microscope, the epidermis layer has to be separated from the rest of the plant part.

eye: a loop knot at the end of a rope. See: loop, eye splice

eye splice: a loop knot at the end of a rope, made by twining or cabling the unravelled ends of the rope in the structure at a lower part. See: splice

fibre identification: the determination of the fibres or plant parts used, by studying the epidermis, a cross-section, a longitudinal section or the individual cells. See: epidermis identification, macerate (v)

fine skein work: for the fine skein technique woodlike materials, such as willow rods are split and alternately planed and cut into ever smaller strips until thin, narrow strips are left. Very regular work can be made with woodstrips that have been prepared in such a manner. See: skein

foundation: the passive element in coiled basketry, also indicated as 'bundle'. See: coiled basketry, bundle, winder

French randing: a basic structure (stake-and-strand) in which a number of horizontal active elements is inserted in between a number of vertical passive elements. The active elements are worked simultaneously (Plate 18, Figure 55). See: English randing

granny knot: a knot which is, similar to the reef knot, but worked in a different orientation (figure 18). The granny knot can be considered as a miss application of the reef knot, since it is much less secure than the reef knot. See: reef knot

grommet: a rope ring, made by splicing two ends of one rope together. Often grommets are used for strengthening an opening. See: splice (n)

half knot: the half knot has the same construction as the overhand knot, but is tied in a different way (figure 14, Plate 4). Instead of tying the knot at one end of the string, the half knot is tied with two ends. These are either two ends of the same string, which is tied around an object, or in two different strings. The half knot occurs in two distinct orientations: S and Z, and forms the basis for several other knots, such as the reef knot and the granny knot. See: knot, overhand knot, reef knot, granny knot

hitch: a knot, tied to an object, which desintegrates if the object is removed. Usually the knot has the appearance of a loop knot, but differs fundamentally from the latter, since it is not tied in the hand, but around an object. See: knot, loop

I: indication of an orientation of spun yarns, plied strings, and basketry techniques, such as slewing (Figures 6, 36). See: S, Z

knitting: characteristic for knitting is the linking of a continuous strand by picking up the strand through loops which are formed by the same strand in a former row. See: spool knitting

knob knot: a knot which forms a bulbous shape at the end of a rope. Knob knots are used as stoppers: the knot either stops the rope from unravelling, or stops the rope from slipping through a hole or loop.

knot: any construction of string which has been made according to a scheme or plan. In general the scheme or plan is known to several people in a society. This broad definition includes bends, hitches and splices. See: bend, hitch, splice, loop, eye. More specifically a *knot* is a knob at the end of a rope, which has the function of stopper. The *overhand knot*, being the simplest form of a *knob knot*, is a knot in this more specific sense. See: knob knot, stopper, overhand knot

knottng: all connections which involve more than one crossing of yarns. Thus Figure 15 is a crossing, while Figure 16 can be considered a knottng.

loop: the part of a rope in which the two ends are closing in on each other, without crossing (Figure 12). Often the term *loop* is used where *loop knot* is meant.

loop knot: any knot or splice which is made in two parts of the same rope, thus forming a looped part. The loop knot can be fixed or running, as in lassoes. A fixed loop knot at the end of a rope is indicated as an *eye*. See: eye, eye splice

macerate (v): soaking and boiling up plant parts in order to isolate plant cells, for the purpose of fibre identification.

mesh knot: the knot used in making nets, usually with the help of a netting needle (Figures 19, 20, 21). The mesh knot has two distinctive orientations, expressed by the letters S and Z. See: netting needle

netting: general term for all widely spaced techniques made out of cordage. These techniques include knotting with mesh knots, reef knots, overhand bends and half knots (Figures 20-24).

netting needle: a tool with which netting knots are tied, in the form of a long flat shuttle, usually forked, or with two hooks at the ends, on which a quantity of string is wound.

open trail work: stake-and-strand techniques with widely spaced stakes and strands. See: stake-and-strand

osier: willow rods.

overhand knot: the overhand knot has the same construction as the *half knot*, but is knotted in one string only (see Figure 14, Plate 3). The overhand knot occurs both at the end of a string as the simplest form of a knob knot, often used as stopper, and in the middle of a string. The overhand knot occurs in two distinct orientations: S and Z. See: knot, knob knot, half knot

pair (v): pairing is a combination of two active strands, which are interacting. Usually pairing occurs in stake-and-strand basketry, to connect the passive stakes

(Figure 36 d and e). The active elements can be paired in two directions: S and Z. This technique is also known as *twining*. See: stake-and-strand basketry, twined basketry

passive: elements forming the body of a basketry structure, without having an actual part in creating the coherency in the technique, are considered to be passive elements. See: active

passive conservation: ensuring objects to remain in absolute stable conditions, in order to prevent further deterioration. For archaeological basketry this means a stable temperature of 18°-20°C and a relative humidity of 50-55%, for ethnographical basketry from an ethnographical context the relative humidity is best kept at a stable value of 62% (see page 113).

peeling: a preparation of raw materials, removal of the outer skin before use. The bark of osiers, for instance, is peeled to obtain white rods.

plait (n): three or more strands interlaced (Figure 8). The variety of plaits includes round plaits (Figure 9), plaited strips (Figures 37-41) and continuous plaiting (figure 79). A typical feature for plaiting is that all strands are active.

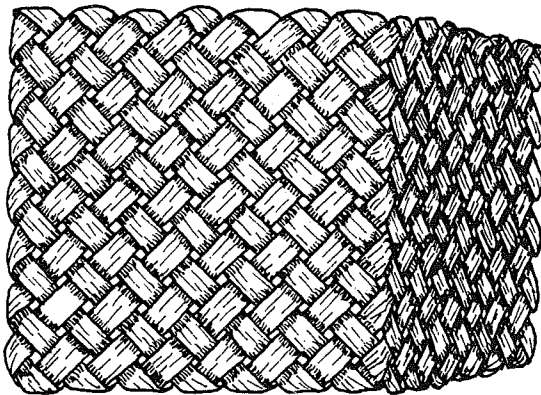

Figure 79. Continuous plaiting

plait index (PI): first, the ratio is calculated of the width of a number of strands and the length over which these strands extend. From this ratio both the PI and the angle of plait can be calculated. The PI is the ratio, multiplied by 141.421. The angle of plait can be assessed by calculating the inverse sine from the ratio and multiplying the result by two (pp. 67-68, Figures 46-47, Appendix B). See: angle of plait

ply (v): the turning of two or more yarns around each other in order to form a strand, referred to as string. Plying can be done in two directions: S and Z. Two parallel yarns with no obvious ply are recorded as the capital letter I. See: yarn, string, cable

rapping iron: a metal oblong weight, used to beat down the sides of a wicker basket, in order to obtain a compact weave at the side.

reef knot: a knot made up of two half knots in opposite orientation. Although the reef knot is symmetrical, two orientations can be distinguished: SZ or ZS (first the S-half knot, then the Z-half knot or vice versa). Figures 17 and 22. See: knot, half knot

retting: a preparation of raw material by which the plant parts are left to soak in water, in order to lose the soft plant cells in a rotting process. The tougher cells (sclerenchyma, collenchyma) remain and are used as raw material. Among the many plant species which are prepared by this method are: *Linum ussitatissimum* (flax), *Cannabis sativa* (hemp) and *Boehmeria nivea* (ramee).

rim: a term which indicates the edge of a basket. *Rim* is used in the description of the shape of the object. The edge of the technique is indicated as *border*. The equivalent term for the edge of flat objects, rather than containers, is *edge*. See: border, edge

rod: the active element in stake-and-strand basketry (also indicated as weaver or strand). See: weaver, stake, strand

rope: general term for plied or plied and cabled strands. See: string, cable

row: the number of times that the basketmaker has worked around the centre of a round or oval basket. Rows are counted separately for the base and the side of a basket, unless the transition between base and side is not clear. In the latter case the total number of rows is counted. For baskets without a clear centre (often rectangular baskets or trays) the number of rows of active strands passing over one passive strand is counted (see pp. 75-77).

S: indication of the orientation of spun yarns, plied strings, cables, knots, and several basketry techniques, such as pairing and waling (Figures 6, 7, 15-23, 36). See: Z, I

selvedge: the edge of a basket or mat in which the strands do not need to be fastened off. Usually the strands continue at the edge, but change direction. Not all techniques produce selvedges. The plaited strips of Figures 37, 38, 40 and 41 are good illustrations. Another example is the side edge of twined mats. See: border, edge, rim

sennit: see sinnet

set of elements: a number of strands of the same material, performing the same task in a technique (page 54).

sinnet: cordage formed by knotting or plaiting yarns and strings (Figures 9 and 11). Also known as sennit. See: crowning, plait (n)

skein: thin narrow strips made by planing and cutting down split rods, e.g. willow rod. Even the finest skeins have considerable strength since the weak core side is planed down, but the strong elastic bast side (the part of the rods just under the bark) is left. See: fine skein work

slew (v): a stake-and-strand technique (a set of passive elements, held into place by active elements which operate at a right angle to the passive elements) which is characterised by working with a number of parallel strands (elements which consist of more than one member, I-orientated, see Figure 36 b and c).

spin (v): fibres twisted into a strand, referred to as yarn. The spinning can be done in two directions: s and z. Unspun yarns are indicated by the letter i. See: yarn, string, cable, twist (v)

splice (n): plying or cabling unravelled ends into a rope. A splice is used to make a connection between two ropes, to finish off the end of a rope, or to make eyes and grommets. See: eye splice, grommet

spool knitting: a cordage technique in which a continuous strand is knitted in a circle with a small diameter. This technique is also known as *bobbing knitting* or *French knitting* (see Figure 10). See: knitting

stake: the passive elements in a stake-and-strand basket. See: strand, rod, weaver

stake-and-strand basketry: a technique which involves two systems: a passive system, consisting of a number of elements (*stakes*), and an active system which interweaves the passive system, usually at a right angle (*strand, rod, weaver*). See: *wickerwork*, stake, strand, rod, weaver.

standing part: part in the middle of a rope which is not active in knotting. See: working end, bight

strand: general term for all lengths of material which are used in basketry and cordage. Specific meaning with regard to stake-and-strand basketry: the active elements. See: stake, rod, weaver

string: two or more yarns plied into a long strand. The string can be plied in an S, Z, or an I direction, the latter only occurring in cabled ropes, in which the direction of ply is not clearly visible, because of the cabling. See: ply (v), yarn, cable

stopper: a functional term for knots which stop a rope from unravelling, or prevent the rope from slipping through a hole or loop. *Knob knots* are generally tied to function as stoppers. The *overhand knot*, being the simplest form of a knob knot, is an example of a stopper. See: knob knot, overhand knot

system: an element (or set of elements, all made of the same material and performing the same task in a technique) which is part of the basic structure of a technique (see pp. 49-53 and Figure 31).

technique: the structure which makes up a basket or cord. The technique includes the *basic structure*, as well as the fastening of the elements at the start and border of the object. See: technology

technology: the knowledge needed to make an object. Technology includes the preparation of the raw material, the working order, the position of the producer while at work and the tools involved. See: technique

top: the thin end of a (willow) rod. See: butt

twill: a technique which consists of two systems, and has an oblique appearance, which is caused by the fact that the shift of the pattern is less than the number of strands that are crossed (see page 63 and Figures 40, 41, 45, 47).

twine (v): see pair (v)

twined basketry: a stake-and-strand technique (a set of passive elements, held into place by active elements which operate at a right angle to the passive elements) which is characterised by the combination of two members per element. The two strands are turned alternately behind and in front of the stakes. The twining can be done in both an S and a Z orientation. See: pair (v)

twist (v): the turning of plant parts while one end is fixed, thus loosening the fibres. The difference between twisting and spinning is that in spinning separate fibres are made into a long yarn, while the term twisting is confined to the loosening of the fibres of a part of a plant without making it into a new unity. The plant parts can be used while still twisted (in either S or Z direction), or untwisted (I). Twisted rods are for instance used for the handles of willow baskets. See: spin (v)

wale (v): a stake-and-strand technique (a set of passive elements, held into place by active elements which operate at a right angle to the passive elements) which

is characterised by the combination of three or more members per element. The two strands are turned in front of a number of stakes and behind one stake (the total of stakes involved counting up to the number of members with which one is waling). The waling can be done in both an S and a Z orientation, dependent on the direction in which the waling is done ('e' or 'reversed e'), see Figure 36 f and g.

weaver: the active element in stake-and-strand basketry, also indicated as *rod* or *strand*. See: rod, stake, strand

wickerwork: a stake-and-strand basket made out of willow rods (osier). See: stake-and-strand basketry

winder: the passive element in coiled basketry. See: bundle

working end: extremity of a rope which is active in knotting (i.e. handled to make the knot). See: end, standing part, bight

yarn: fibres spun or twisted into a strand, either in an s, z, or i direction. See: spin (v), string, cable, I, S, Z, twist (v)

Z: indication of the orientation of spun yarns, plied strings, cables, knots, and several basketry techniques, such as pairing and waling (Figures 6, 7, 15-23, 36). See: S, I

BIBLIOGRAPHY

anonymous

1983 'Care of basketry' (CCI ICC Notes 6/2). Ottawa: ICCOM

Adams, W. Y., J. A. Alexander and R. Allen

1983 'Qasr Ibrim 1980 and 1982', *Journal of Egyptian Archaeology* 69, pp. 43-66

Adovasio, J. M.

1977 *Basketry Technology. A Guide to Identification and Analysis* (Aldine Manuals on Archaeology). London: Aldine Publishing Company

Aitken, M. J.

1990 *Science-based Dating in Archaeology*. London and New York: Longman

Ashley, C. W.

1947 *The Ashley Book of Knots*. London: Faber and Faber

Blackman, W. S.

1927 *The Fellahin of Upper Egypt. Their Religious Social and Industrial Life To-day with Special Reference to Survivals From Ancient Times*. London: George G. Harrap & company

Bobart, H. H.

1971 *Basketwork Through the Ages*. Detroit: Singing Tree Press (reprint of edition London 1936)

Bonnet, C. (ed.)

1990 *Kerma royaume de Nubie*. Genève: Musée d'art et d'histoire

Catling, D. M. and J. E. Grayson

1982 *Identification of Vegetable Fibres*. London, New York: Chapman and Hall

Conlon, V. M.

1973 *Camera Techniques in Archaeology*. London

Cooke, W. D. and B. Lomas

1978 'Ancient textiles - modern technology', *Archaeology Today*, March 1978, pp. 21-25

- Cooke, W. D.
1988 'Creasing in ancient textiles', *Conservation News*, 35, March 1988, pp. 27-30
- Crowfoot, G. M.
1954 'Textiles basketry and mats'. In: C. Singer, E. J. Holmyard and A. R. Hall (eds.), *A History of Technology*. Oxford University Press. Vol. I, pp. 413-451
- Crowfoot, G. M.
1938 'Mat impressions on pot bases', *Annals of Archaeology and Anthropology* 25, nos. 1-2, pp. 3-11
- Dowman, E. A.
1970 *Conservation in Field Archaeology*. London: Methuen
- Dunnell, R. C.
1971 *Systematics in Prehistory*, New York: The Free Press
- Emery, I.
1980 *The Primary Structure of Fabrics. An Illustrated Classification*. Washington D.C.: The Textile Museum
- Forbes
1964 'Sewing basketry and weaving', *Ancient Technology* IV, pp. 175-195
- Fouilles Françaises
1981 *Un siècle de fouilles Françaises en Egypte; 1880-1980*, Cairo/Paris: Institut Français d'Archéologie Orientale
- Gaitsch, W.
1986 *Antike Korb- und Seilerwaren* (Schriften des Limesmuseums Aalen, Nr. 38). Aalen: Württembergischen Landesmuseum Stuttgart
- Gourlay, Y. J.-L.
1981 *Les Sparteries de Deir el-Médineh: I Catalogue des techniques de sparterie* (Documents de fouilles tome XVII/1). Cairo: Institut Français d'Archéologie Orientale
- Gourlay, Y. J.-L.
1981 *Les sparteries de Deir el-Médineh: II Catalogue des objets de sparterie*, (Documents de fouilles tome XVII/2). Cairo: Institut Français d'Archéologie Orientale

- Greiss, E. A. M.
1949 'Anatomical identification of plant material', *Bulletin Internationale d'Egyptologie* 31, pp. 249-283
- Greiss, E. A. M.
1957 *Anatomical Identification of Some Ancient Egyptian Plant Materials* (Memoires d'Institut d'Egypte, Tome 55).
- Griset, S.
1986 'Preventative conservation measures for an ethnographic collection', *The International Journal of Museum Management and Curatorship* 5, pp. 371-382
- Hurley, W. M.
1989 *Prehistoric Cordage. Identification of Impressions on Pottery*, Aldine Manuals on Archaeology 3, Chicago: Taxacum
- Jong, J. de
1975 *The Conservation of Waterlogged Timber at Ketelhaven (Holland)* (ICOM Committee for Conservation 4th Triennial Meeting) Venice: ICOM
- Kühn, H.
1981 *Erhaltung und Pflege von Kunstwerken und Antiquitäten mit Materialkunde und Einführung in künstlerischen Techniken*. München: Keyserische Verlagbuchhandlung
- Leeuw, S. E. van der
1976 'Neolithic beakers from The Netherlands: the potter's point of view'. In: *Glockenbecher Symposium*, Oberried 1974, Bussum/Haarlem: Fibula - van Dishoeck (pp. 81-140)
- Loon, M. N. van (ed.)
1978 *Korucetepe 2, Find Report on the Excavations of the Universities of Chicago, California (Los Angeles) and Amsterdam in the Keban Reservoir, Eastern Anatolia* (Studies in Civilization). Amsterdam: North Holland Publishing Company
- Lucas, A. and J. R. Harris
1962 *Ancient Egyptian Materials and Industries*. London: Edward Arnolds (4th revised edition of London 1926)
- Michels, J. W.
1973 *Dating Methods in Archaeology*. New York: Seminar press

- Mook, W.G. and H. T. Waterbolk
 1985 *Radiocarbon Dating* (Handbooks for Archaeologists, No. 3).
 Strasbourg: European Science Foundation
- Mueller, J. W. (ed.)
 1979 *Sampling in Archaeology*. Tuscon: The University of Arizona Press
- Nettinga-Arnheim, M. R.
 1977 *Basketry and Basketry Techniques. A Study in the Horniman
 Museum*. Groningen: Instituut voor Culturele Antropologie R.u.G.
- Price, N. and P. Stanley (ed.)
 1984 *Conservation on Archaeological Excavations with Particular Refer-
 ence to the Mediterranean Area*. Rome: ICCROM (International
 Centre for the Study of the Preservation and Restoration of
 Cultural Property)
- Roelofs, W. and J. A. Mosk (eds.)
 1986 *Bestrijding van insecten en schimmels in musea* (Centraal
 Laboratorium voor onderzoek naar voorwerpen van kunst en
 wetenschap, Themadag no. 9). Amsterdam: Centraal
 Laboratorium
- Sease, C.
 1987 *A Conservation Manual* (Archaeological Research Books 4). Los
 Angeles: Institute of Archaeology of the University of California
- Seiler-Baldinger, A.
 1973 *Systematik der Textilten Techniken* (Basler Beitrage zur Ethnologie
 Band 14). Basel: Pharos - Verlag Hansrudolf Schwabe
- Simmons, H. C.
 1969 *Archaeological Photography*. London: University of London Press
- Wendrich, W. Z.
 1989 'Preliminary report on the Amarna basketry and cordage',
Amarna Reports V, London: Egypt Exploration Society (pp.
 169-201)
- Wendrich, W. Z.
 1990 'Vlechtwerk, zelfkant van het specialisme textiel?' *Oudheidkundige
 Mededelingen van het Rijksmuseum van Oudheden* 10, pp. 211-216.
 Leiden: Rijksmuseum van Oudheden

Wendrich, W. Z.

1991 'Basketry, a textile technique?' *Archaeological Textiles Newsletter*
12, p. 10. Leiden: Vogelsang

Westendorp, A., A. D. van 't Hoog and W. D. J. Tuinzing

1985 *Het vlechten van ovale manden met teen*. IJsselstein: Stichting Wilg
& Mand

Wright, D.

1983 *The Complete Book of Baskets and Basketry*. London: David &
Charles



INDEX

- Abu Sha'ar 36, 123, 127
active 50, 53-57, 59, 65, 66, 69-72,
74, 75, 79, 81, 84, 90, 91, 96,
109, 135, 136, 138, 140-146
Adovasio 2, 3, 132
Amarna 14, 38, 39, 69, 70
analysis 2, 3, 19, 21, 24-26, 97-99,
107, 110
angle of plait 39, 59, 66, 68, 129,
133, 135, 142
application 95
Ashley 3, 33, 44, 46
aspect 22, 24, 53, 135, 137
attribute 22-23, 135, 137
- base 7, 14, 18, 48, 69, 72, 74-79, 83,
84, 88, 89, 92-94, 96, 143
basic structure 21, 48, 49, 69, 72, 74,
78, 80, 84, 94, 96, 99, 103, 135,
137, 138, 145
bell chamber 9, 115, 116, 135
bend 3, 135, 139
bight 136, 144, 146
bodkin 136
border 84, 136, 137, 142, 143, 145
bow knot 40, 136
bundle 70, 71, 74, 84, 90, 99, 136,
138, 146
butt 79-81, 83, 90, 136, 145
- cable 30-34, 38, 59, 62, 86, 136, 137,
142, 144, 146
carbonization 13, 29
centre 15, 72, 73, 75, 83, 84, 143
cleaning 5, 9, 19, 101, 114
coherency 49, 53, 54, 56, 65, 84, 100,
109, 114, 117, 119, 135, 141
coiled basketry 85, 136, 138, 146
colour 9, 21, 29, 95, 100, 131, 135
conservation 10, 11, 18, 19, 101, 113,
114, 116-120, 131, 141
context 5, 10, 18, 25-27, 97, 102,
110, 120, 141
continuation 74, 78
cord 7, 33, 34, 37-39, 59, 86, 137,
145
cord index (CI) 7, 33-39, 59, 137
cordage 1-4, 11-13, 17, 18, 27, 30,
31, 33, 34, 36, 59, 86, 94, 98,
110, 115, 116, 118-121, 123,
127, 131, 137, 140, 143, 144
cover 71, 94, 97, 103
- cyano acrylate glue 119, 131
- decoration 21, 73, 92, 95, 96, 135
description 1, 27, 29, 59, 66, 84, 93,
100-102, 109, 142
dimension 22, 23, 135, 137
dimensions 59, 80, 86-88, 90, 92,
103, 137
direction of ply 30, 31, 144
direction of spin 30, 59
dry 9, 10, 12, 13, 17, 100, 111,
113-116, 118, 119, 132
- edge 44, 60, 62, 64, 84, 136, 137,
142, 143
element 54-58, 66, 70, 72, 74, 75, 81,
84, 85, 90, 135-138, 142, 145,
146
Emery 21, 45
English randing 80, 81, 83, 137, 138
epidermis identification 109, 138
equipment 4, 7-10
exhaustion 80, 83
eye 47, 92, 138-140, 144
eye splice 138, 140, 144

- facing system 69, 71
 fibre identification 10, 98, 99, 108,
 109, 138, 140
 fine skein work 77, 138, 143
 flexible 34, 53, 56, 71, 81, 132
 foot 94
 fossilization 11, 13, 29
 foundation 14, 136, 138
 French randing 81, 82, 137, 138

 granny knot 43, 44, 136, 138, 139
 grommet 138, 144

 half knot 40-42, 139, 140, 142
 handles 18, 84, 94, 145
 hitch 3, 135, 139

 identification 28, 93, 103
 impression 10, 13, 14, 19, 20, 27,
 100
 increasing 34, 78
 insertion 55, 73, 80, 83
 irregularities 88, 89, 97, 129

 knot 3, 7, 39-44, 46, 47, 135, 136,
 138-140, 142, 144, 146
 bow 40, 136
 granny 43-44, 136, 138, 139
 half 40, 41, 139, 140, 142
 knob 135, 139, 140, 144
 loop 138-140
 mesh 44, 140
 overhand 39, 40, 45, 139, 140, 144
 reef 42, 136, 138-140, 142

 labels 10, 110, 121
 lid 94
 loop 34, 138-140, 144
 loop knot 138-140

 macerate 109, 138, 140
 macroscopical view 98
 member 56, 58, 143
 mesh circumference 87

 mesh knot 44, 140
 mesh size 87
 metallographic microscope 98
 method of shaping 48, 83, 84
 microscopical examination 98
 moist 100, 114, 115

 netting 44-47, 86, 87, 116, 119, 123,
 127, 140
 netting needle 44, 140
 no. of elements 75, 79
 no. of rows 75, 79

 open trail work 84, 97, 140
 opening 87, 138
 orientation 39-44, 46, 49, 51, 53, 54,
 58, 63, 72, 73, 75, 78, 79, 135,
 137-139, 142, 143, 145, 146
 osier 140, 146
 overhand knot 39-41, 45, 46, 139,
 140, 144

 packing 19, 110, 114, 117, 119, 120
 pairing 58, 140, 143, 146
 Paraloid 131
 passive 50, 53-58, 60, 65, 69-72, 75,
 77-83, 85, 90, 91, 96, 109, 113,
 135, 136, 138, 140, 141, 143-146
 passive conservation 113, 141
 peeling 109, 141
 PEG 131, 132
 photography 7, 9, 17, 18, 27, 28
 plait 7, 30, 33, 34, 39, 59-68, 78, 129,
 133, 135, 137, 141-143
 plait index (PI) 66, 68, 129, 135, 142
 plait pattern 65, 66
 ply 30, 31, 33, 34, 37-39, 59, 62, 137,
 142, 144
 poly-urythane 132
 preparatory work 59, 68
 preservation 5, 11-13, 29, 107, 113,
 116
 PVA 132
 PVC 20, 132

- Qasr Ibrim 12, 64, 123
- rapping iron 142
- raw material 4, 7, 12, 21, 22, 34, 47-49, 55, 59, 80, 88-90, 98, 99, 107, 108, 135, 142, 145
- re-use 97
- reef knot 42, 136, 138, 139, 142
- relative humidity (RH) 22, 113, 120, 141
- remarks 27, 30, 84, 103
- repair 96, 117
- restoring shape 115
- retting 59, 99, 109, 142
- reversed e - orientation 72, 73, 78, 146
- reversing agent 101
- rigid 56, 71
- rim 14, 18, 48, 69, 83-85, 89, 92-94, 96, 97, 136, 137, 142, 143
- rod 69, 79-81, 83, 90, 136, 137, 142-146
- rope 3, 27, 31-34, 36, 39, 40, 59, 86, 123, 136-140, 142, 144, 146
- row 44, 75, 78, 102, 139, 143
- S-direction 30, 32, 44, 58, 62, 64, 90
- sampling 5, 19, 26, 99, 107, 108, 110
- secondary finds 97
- Seiler-Baldinger 21
- selvedge 88, 136, 137, 143
- semi-flexible 71
- sennit 143
- set of elements 49, 54, 75, 81, 135, 143, 145
- shift 60, 64-66, 68, 75, 81, 84, 145
- sinnet 35, 137, 143
- skein 77, 78, 138, 143
- slewing 58, 139
- soluble nylon 131
- special features 26, 27, 93, 94, 96
- spin 30, 34, 38, 39, 59, 62, 137, 144-146
- splice 3, 135, 138-140, 144
- spool knitting 33, 35, 139, 144
- sP[C] 30, 59
- stains 7, 97, 114, 120
- stake 73, 78-81, 84, 96, 137, 138, 140-146
- stake-and-strand basketry 140-142, 144, 146
- standing part 136, 144, 146
- stopper 40, 139, 140, 144
- storage 5, 10, 19, 27, 101, 113, 114, 119-121
- strand 33, 54, 56, 60-65, 67, 68, 73, 75, 78-80, 84, 96, 136-146
- strengthening 58, 96, 138
- string 3, 7, 14, 30-34, 38-41, 47, 59, 61, 63, 64, 69, 78, 86, 87, 135-137, 139, 140, 142, 144, 146
- supplies 7-10
- system 2, 3, 9, 49, 51, 53, 54, 56, 59, 65, 69, 71, 72, 75, 79-81, 89, 90, 99, 109, 135-137, 144, 145
- technique 3, 4, 7, 12, 13, 21, 22, 24, 30-85, 89, 92, 94-97, 99, 103, 110, 116, 135, 136, 138, 141-145
- technology 2, 25, 34, 145
- temperature 113, 120, 131, 141
- top 28, 65, 73, 80, 81, 83, 90, 93, 109, 116, 136, 145
- transition base-side 48
- treatment 4, 5, 7, 17, 19, 27, 101, 107, 109, 110, 113, 116, 117, 119, 121
- twill 63, 66-68, 145
- twined basketry 47, 141, 145
- twining 3, 58, 138, 141, 145
- twisting 30, 68, 145
- use 1, 25, 27, 96-98, 102-103
- waling 58, 83, 84, 96, 143, 146
- waterlogged 9, 12, 13, 18, 19, 100, 113, 114, 118, 119
- wear 70, 73, 97, 117
- weaver 81, 142, 144, 146

wet 12, 13, 17, 107, 111, 113-115,
118, 119, 132

wickerwork 144, 146

winder 136, 138, 146

working end 136, 144, 146

yarn 30, 32, 86, 87, 136, 142,
144-146

Z-direction 30, 32, 44, 58, 62

| | | | | | |
|---|--|---|--|--|--|
| description: ID number: <input style="width: 50px;" type="text"/> 1 site/museum: photo archive date: black&white: researcher: slides: complete/greater part/fragment/other way of preservation: | | 1 IDENTIFICATION description: ID number: <input style="width: 50px;" type="text"/> 1 site/museum: photo archive date: black&white: researcher: slides: complete/greater part/fragment/other way of preservation: | | | |
| 2 TECHNIQUE sP[C]: plait: other: Cl _s : <input type="text"/> x100 = Cl _p : <input type="text"/> x100 = Cl _c : <input type="text"/> x100 = PI: description/drawing: | <input type="checkbox"/> overhand knots S-orientation <input type="checkbox"/> overhand knots Z-orientation <input type="checkbox"/> half knots S-orientation <input type="checkbox"/> half knots Z-orientation <input type="checkbox"/> reef knots SZ-orientation <input type="checkbox"/> reef knots ZS-orientation <input type="checkbox"/> granny knots SS <input type="checkbox"/> granny knots ZZ <input type="checkbox"/> mesh knots S-orientation <input type="checkbox"/> mesh knots Z-orientation <input type="checkbox"/> other knots | 2 TECHNIQUE sP[C]: plait: other: Cl _s : <input type="text"/> x100 = Cl _p : <input type="text"/> x100 = Cl _c : <input type="text"/> x100 = PI: description/drawing: | <input type="checkbox"/> overhand knots S-orientation <input type="checkbox"/> overhand knots Z-orientation <input type="checkbox"/> half knots S-orientation <input type="checkbox"/> half knots Z-orientation <input type="checkbox"/> reef knots SZ-orientation <input type="checkbox"/> reef knots ZS-orientation <input type="checkbox"/> granny knots SS <input type="checkbox"/> granny knots ZZ <input type="checkbox"/> mesh knots S-orientation <input type="checkbox"/> mesh knots Z-orientation <input type="checkbox"/> other knots | | |
| 3 DIMENSIONS (in mm.) length: diameter cable: diameter string: diameter yarn: | | NETTING maximum dimensions LxW: mesh size: + + + mesh circumference: opening: other dimensions: | 3 DIMENSIONS (in mm.) length: diameter cable: diameter string: diameter yarn: | | NETTING maximum dimensions LxW: mesh size: + + + mesh circumference: opening: other dimensions: |
| 4 SHAPE see page ... | | 4 SHAPE see page ... | | | |
| 5 SPECIAL FEATURES colour <input type="checkbox"/> irregularities <input type="checkbox"/> decoration <input type="checkbox"/> stains <input type="checkbox"/> strengthening <input type="checkbox"/> wear <input type="checkbox"/> repair <input type="checkbox"/> secondary finds <input type="checkbox"/> re-use <input type="checkbox"/> other <input type="checkbox"/> description/drawing: | | 5 SPECIAL FEATURES colour <input type="checkbox"/> irregularities <input type="checkbox"/> decoration <input type="checkbox"/> stains <input type="checkbox"/> strengthening <input type="checkbox"/> wear <input type="checkbox"/> repair <input type="checkbox"/> secondary finds <input type="checkbox"/> re-use <input type="checkbox"/> other <input type="checkbox"/> description/drawing: | | | |
| 6 MATERIAL sample Y / N common / exceptional | | <input type="checkbox"/> macroscopical view <input type="checkbox"/> microscopical examination magnification X microscope: method: <input type="checkbox"/> other | | | |
| 7 CONDITION waterlogged / moist / dry general impression: fibre: coherency: description: colour: | | 8 TREATMENT date: cleaning: conservation: reversing agent: other: | | | |
| 9 STORAGE present location object: | | 10 CONTEXT present location object: | | | |
| 11 USE see page ... | | 12 REMARKS see page ... | | | |

| | | |
|---|--|---|
| 1 IDENTIFICATION site/museum: number: date: researcher: | photo archive black&white: slides: | ID number: 1 description: complete/greater part/fragment/other way of preservation: |
| 2. TECHNIQUE BASIC STRUCTURE no. of systems [] System 1 one element/set of elements active/passive no. of members [] S / Z / I preparatory work: none <input type="checkbox"/> corded <input type="checkbox"/> plaited <input type="checkbox"/> other: System 2 one element/set of elements active/passive no. of members [] S / Z / I preparatory work: none <input type="checkbox"/> corded <input type="checkbox"/> plaited <input type="checkbox"/> other: System 3 one element/set of elements active/passive no. of members [] S / Z / I preparatory work: none <input type="checkbox"/> corded <input type="checkbox"/> plaited <input type="checkbox"/> other: | BASE scheme of centre: orientation inside base: e / reversed e continuation (scheme): active system [] passive system [] no. of elements: no. of elements: no. of rows: no. of rows: other systems (specify): increasing (scheme): see page ... | SIDE scheme basic structure: orientation inside: e / reversed e active system [] passive system [] no. of elements: no. of elements: no. of rows: no. of rows: other systems (specify): insertion/exhaustion: see page ... |
| 3 DIMENSIONS (in mm.) OBJECT maximum dimensions LxWxH: X X average thickness: maximum circumference: minimum circumference: diameter base: circumference base: diameter rim: circumference rim: | ELEMENTS AND RAW MATERIAL system 1: length elements: diam./width elements: space between elements: length material: diam./width material: other: system 2: length elements: diam./width elements: space between elements: length material: diam./width material: other: system 3: length elements: diam./width elements: space between elements: length material: diam./width material: other: | TRANSITION BASE-SIDE METHOD OF SHAPING description/drawing: see page ... |
| 4 SHAPE (drawing to scale: side view with transverse section; bird's eye view) | base: round / oval / square / rectangular / triangular / other: side: round / oval / square / rectangular / triangular / other: rim : round / oval / square / rectangular / triangular / other: | |

see page ...

5 SPECIAL FEATURES

| Deliberate | | Indeliberate | |
|---------------|--------------------------|-----------------|--------------------------|
| handles | <input type="checkbox"/> | irregularities | <input type="checkbox"/> |
| cover/lid | <input type="checkbox"/> | stains | <input type="checkbox"/> |
| foot | <input type="checkbox"/> | wear | <input type="checkbox"/> |
| colour | <input type="checkbox"/> | secondary finds | <input type="checkbox"/> |
| decoration | <input type="checkbox"/> | | |
| application | <input type="checkbox"/> | | |
| strengthening | <input type="checkbox"/> | other | <input type="checkbox"/> |
| repair | <input type="checkbox"/> | | |
| re-use | <input type="checkbox"/> | | |

description/drawing:

see page ...

6 MATERIAL

method:

macroscopical view
 microscopical examination, magnification X
 light microscope / stereo micr. / metallographic micr. / SEM
 cross section / longitudinal section / epidermis
 other

all systems separate (stakes, strands, bundle, winders, etc.)
 latin name and local name

system 1: sample Y/N
 system 2: sample Y/N
 system 3: sample Y/N
 other:
 reason for sampling: common/exceptional

7 CONDITION

waterlogged / moist / dry
 general impression:
 fibre:
 coherency:

description:

colour:

8 TREATMENT

cleaning:

date:

conservation:

date:

other:

date:

reversing agent:

9 STORAGE

storage:

present location object:

10 CONTEXT site information / history

see page ...

11 USE

see page ...

12 REMARKS

re..

ID number: 1**1 IDENTIFICATION**

site/museum:

number:

date:

researcher:

photo archive

black&white:

slides:

description:

complete/greater part/fragment/other way of preservation:

2 TECHNIQUE

no. of systems []

System 1

one element/set of elements

active/passive

no. of members [] S/Z/I

preparatory work:

none corded plaited

other:

System 2

one element/set of elements

active/passive

no. of members [] S/Z/I

preparatory work:

none corded plaited

other:

System 3

one element/set of elements

active/passive

no. of members [] S/Z/I

preparatory work:

none corded plaited

other:

see page ...

3 DIMENSIONS (in mm.)

OBJECT

maximum dimensions LxWxH:

X X

average thickness:

maximum circumference:

minimum circumference:

ELEMENTS AND RAW MATERIAL

system 1:

length elements:

diam./width elements:

space between elements:

length material:

diam./width material:

other:

system 2:

length elements:

diam./width elements:

space between elements:

length material:

diam./width material:

other:

system 3:

length elements:

diam./width elements:

space between elements:

length material:

diam./width material:

other:

OTHER DIMENSIONS:

4 SHAPE

(drawing to scale: side view with transverse section; bird's eye view)

see page ...

