

## **UC Merced**

# **Proceedings of the Annual Meeting of the Cognitive Science Society**

### **Title**

Framed: Factors influencing reference frame choice in tabletop space

### **Permalink**

<https://escholarship.org/uc/item/48m832qx>

### **Journal**

Proceedings of the Annual Meeting of the Cognitive Science Society, 32(32)

### **ISSN**

1069-7977

### **Authors**

Robinette, Laurie

Feist, Michele

Kalish, Michael

### **Publication Date**

2010

Peer reviewed

# Framed: Factors influencing reference frame choice in tabletop space

**Laurie E. Robinette (ler6578@louisiana.edu)**

Institute of Cognitive Science, University of Louisiana at Lafayette  
Lafayette, LA 70504 USA

**Michele I. Feist (feist@louisiana.edu)**

Institute of Cognitive Science, University of Louisiana at Lafayette  
Lafayette, LA 70504 USA

**Michael L. Kalish (kalish@louisiana.edu)**

Institute of Cognitive Science, University of Louisiana at Lafayette  
Lafayette, LA 70504 USA

## Abstract

While English speakers generally rely on a viewer-centered frame of reference when interpreting table-top space, they will also adopt an object-centered frame in certain situations—prompting the question: *What factors determine which frame?* The current research investigates two possible contributors: the intrinsic “frontedness” of a reference object involved in the scene and the syntactic structure of the sentence used to describe the scene. If an object possesses an “intrinsic front side,” then this side should highlight the properties necessary for the object to be capable of having its own distinguishable perspective. Also, certain linguistic constructions may further increase the salience of the reference object’s inherent geometrical properties, leading to greater use of an object-centered frame.

**Keywords:** Frame of reference; spatial language.

## Introduction

English spatial terms can be ambiguous as to which area of space they refer if a frame of reference is not established before analyzing any spatial relation between two or more objects. When interpreting descriptions of table-top space, English speakers have been shown to rely primarily on a viewer-centered (VC) frame of reference (Majid, Bowerman, Kita, Haun, & Levinson, 2004); however, interpretation may alternatively depend upon an object-centered (OC) frame (Carlson-Radvansky & Irwin, 1993; 1994) when applicable.

The VC frame – also referred to by Levinson (1996, 2003) as the relative frame and by Miller and Johnson-Laird (1976), Retz-Schmidt (1988), and Carlson-Radvansky and Irwin (1993,1994) as the deictic frame – assigns spatial terms according to the properties of an observer located externally to the scene. For example, a viewer attempting to determine the location of a teacup with respect to a nearby teapot will transfer his or her own left and right sides onto the scene and judge that the teacup is to the left/right of the teapot if the space occupied by the teacup corresponds with the viewer’s own left/right side. Because the VC frame is relative to an external observer, it can be based on different

perspectives: one whose origin is grounded on “ego” (a speaker) and another whose origin has been transferred from “ego” to a third party (an addressee) (Retz-Schmidt, 1988; Levinson, 1996; 2003). If the speaker and the addressee share vantage points, locating one object with respect to another is relatively straightforward; however, if not, their viewpoints may conflict, with the result that spatial term use relying on the VC frame may be ambiguous.

Unlike the VC frame, an OC frame of reference – also referred to as the intrinsic frame by Miller and Johnson-Laird (1976), Retz-Schmidt (1988), and Levinson (1996, 2003) – assigns spatial terms according to the ground object’s inherent properties. With this frame, a viewer attempting to locate the teacup would first determine whether or not the teapot has its own left and right sides and then judge that the teacup is to the left/right of the teapot if the teacup’s occupied space corresponds with the teapot’s left/right. Unlike the VC frame, the OC frame is not affected by the locations of any external observers; regardless of the viewpoints of the speaker and the addressee, the teacup will remain intrinsically to the teapot’s left as long as neither object is moved. However, use of the OC frame will require mental rotation if the vantage points of the viewer and ground object are not aligned, and knowledge of the ground’s orientation (Levelt, 1996). In addition, because many objects may lack inherent left and right sides, the assignment of *left* and *right* in this frame is ambiguous and is influenced by functional properties of the object (Levelt, 1996) as well as the vantage point from which the object is considered (Retz-Schmidt, 1988). Contrary to the findings of Majid et al. (2004), Miller and Johnson-Laird (1976) have argued that interpretations based on the OC/intrinsic frame actually dominate those based on the VC/deictic frame, with VC/deictic interpretations requiring specific qualifications from the speaker, such as “the teacup is to the left of the teapot *from my point of view*.”

In order to better understand the semantics of projective terms, many of which can be used with either a VC or an OC frame of reference, we ask in this paper what factors

in a spatial scene determine which frame will be selected for use.

### Possible Contributing Factors to Frame of Reference Selection

Vandeloise (1991) and Levinson (1996, 2003) suggest that one way to resolve the ambiguity of spatial terms may lie in the structure of the utterance used to describe the scene (see also Levelt, 1996). They argue that rephrasing “the teacup to the left of the teapot” as “the teacup to the teapot’s left” should encourage use of an OC frame because the possessive construction points out that the teapot has its own “left side” that may be separate from the “left side” that a viewer assigns to the scene. Moreover, because this construction is specifically possessive, it may suggest that “the teapot’s left side” is the correct interpretation.

In addition, because use of an OC frame makes more sense when the ground object possesses distinguishable sides (Levelt [1996] argues that the OC frame is only possible if this holds), this frame should be more salient when the object possesses a high degree of “frontedness.” Landau and Jackendoff (1993) argue that the ground object’s inherent axial structure is its most important property, and the more an object can be thought of as possessing a front side, the more viewers should notice that its two horizontal axes are different: one assigns an object’s front and back while the other assigns its left and right. For example, a ground object like a teapot, which has an obvious front side, should encourage greater use of the OC frame because its front side calls attention to its possession of a perspective and orientation governed by its intrinsic front, back, left, and right sides. A ball, on the other hand, should not encourage use of an OC frame because it lacks an inherent front, and therefore lacks distinguishable sides; any sides assigned to it should be more strongly based on a VC perspective.

In the current study, we ask whether these two factors – the syntactic form of the spatial description and the inherent frontedness of the ground object – facilitate use of an OC frame of reference for English speakers’ descriptions of spatial relations in tabletop space.

## Method

### Participants

Twenty-five students from the University of Louisiana at Lafayette who were enrolled in an introductory psychology course received extra credit in return for their participation.

### Stimuli

The task took place on a computer using the E-Prime software package. The stimuli used in the experiment included photographs of a figure and ground taken at a “3/4” angle (halfway between head-on and bird’s-eye). Each scene was presented with a sentence including a locative expression (see Figure 1 for an example).



The black dot is to the left of the jack o' lantern.

Figure 1. Example of fronted object stimulus.

For the sentences, we considered the two locative terms *left* and *right*, which could be aligned with one of the horizontal axes. There were two levels of Sentence Structure: *non-possessive* and *possessive*. Participants either saw sentences of the form “The F is to the left/right of the G,” (non-possessive) or the form “The F is to the G’s left/right” (possessive). These two structures were presented between-participants to forestall a strategy of pairing each structure with a different reference frame.

The pictures each showed one figure - a black dot (a black-painted wooden circle) - paired with one of 6 different ground objects that varied on two dimensions of Frontedness, *fronted* and *non-fronted*. Stimuli in the *fronted* group included a camera, a flower, and a jack o’ lantern; stimuli in the *non-fronted* group included a balloon, a glass, and a watermelon<sup>1</sup>.

The final two variables were Figure Position (FP) and Ground Rotation (GR), which were manipulated to vary the frame of reference with which the picture-sentence pairs were consistent (VC, OC, VC and OC, or none (cf., Carlson-Radvansky & Irwin 1993; 1994). The design included 4 degrees of ground rotation (facing 0, 90, 180, or 270 degrees), and four figure positions (at a 0, 90, 180, or 270 degree arc). VC-consistent arrangements always included FP 270 for *left* and FP 90 for *right*, regardless of Ground Rotation; OC-consistent arrangements depend upon both figure position and ground rotation for their interpretation. Figure 2 shows VC-consistent and OC-consistent FP-GR pairings for *left* and *right* (with stimuli at GR 180 being consistent with both frames) illustrated

<sup>1</sup> Assignment to the fronted or non-fronted group was based on two norming studies. In the first, viewers rated the extent to which different objects were said to have an intrinsic “front side;” objects with low ratings were considered non-fronted, while objects with high ratings were considered fronted. In the second, viewers attempted to select the “front side” of the two types of objects. A chi-square analysis revealed that viewers chose the intended front side significantly more often than the other sides for the objects in the fronted group only.

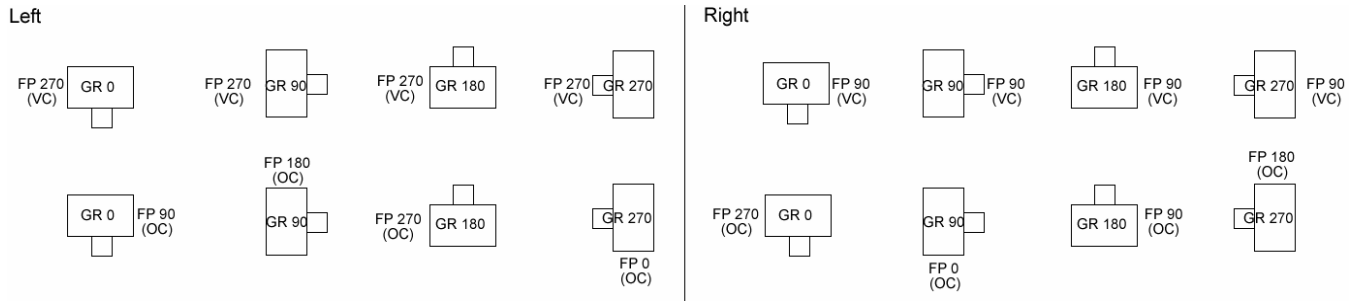

Figure 2. Viewer-centered (VC) and object-centered (OC) assignments of *left* and *right* for fronted objects. Non-fronted objects were assigned similarly to facilitate comparisons between object types.

for clarity with fronted ground objects. Each Figure Position-Ground Rotation combination was created for each of the Ground objects, for a total of 96 pictures.

However, because non-fronted objects cannot truly be said to face in a specific direction in a way that allows the different Ground Rotations—and ultimately, the OC frame of reference—to apply to them, attempting to compare the non-fronted objects to fronted objects becomes problematic. We resolved this issue by including non-fronted objects that possessed a pattern that allowed for their different sides to be discernable upon their rotation, and an arbitrary side was designated as the “front” side so that the objects could be said to “face” in the different directions of Ground Rotation. This designation also allowed for the object to possess “left” and “right” sides. Then, in order to make comparisons between non-fronted and fronted objects, we simply compared ratings at the same Figure Positions and Ground Rotations across object type.

The design of the experiment was 2 (Sentence Structure: *non-possessive* and *possessive*) X 2 (Spatial Term: *left* and *right*) X 2 (Frontedness: *non-fronted* and *fronted*) X 4 (Figure Position: 0, 90, 180, 270) X 4 (Ground Rotation: 0, 90, 180, 270). Spatial Term, Frontedness, Figure Position and Ground Rotation varied within participants, while Sentence Structure varied between participants.

## Procedure

Participants were divided into two groups. One group saw arrangements with corresponding sentences in the *non-possessive* construction, while the other group saw arrangements with corresponding sentences in the *possessive* construction. For the first part of the experiment, participants looked at pictures of the ground objects (one picture per object) in order to introduce each object before the rating task began.

For the rating task, each of the 96 pictures was presented twice, once with a “left”-sentence and once with a “right”-sentence, in random order on a computer screen, for a total of 192 trials. In each case, the participant was asked to rate the acceptability of the sentence as a description of the picture, on a scale from 1

(not acceptable at all) to 5 (very acceptable). The variables for each trial were completely randomized.

## Predictions

Acceptability of OC assignments should be higher when the spatial description is in the possessive structure (“the fork is to the knife’s left”) than when it is non-possessive (“the fork is to the left of the knife”), if awareness of the OC frame is made explicit by the possessive structure. Also, the inclusion of a fronted ground object should lead to higher acceptability of OC assignments than inclusion of a non-fronted object.

Alternatively, implicit awareness of the OC frame may lead to lower ratings of the VC assignments with a possessive structure or fronted object—which would suggest that viewers may at least recognize the possibility of using a different reference frame, even if they are not completely comfortable with it. Such a result might further suggest that the two frames share conceptual space and are simultaneously acceptable in a way that is similar to the predictions of the multiple frame activation hypothesis (Carlson-Radvansky & Irwin, 1994).

Furthermore, object frontedness and the structure of the spatial description should cooperate; when the possessive structure is combined with a fronted ground object, the structure of the description should call attention to the inherent frontedness of that object, maximally increasing acceptability of the OC frame. In this case, we would expect to see a situation in which acceptability of the OC frame surpasses that of the VC frame.

## Results and Discussion

Because our interest is in how Sentence Structure and Frontedness might influence spatial term acceptability across the 16 figure position-ground rotation combinations, we will focus our discussion on higher-order interactions with the variables of figure position and ground rotation.

### Sentence Structure

Figures 3a and 3b show that Sentence Structure influenced the pattern of acceptability across the figure position-ground rotation combinations,  $F(9, 207), =$

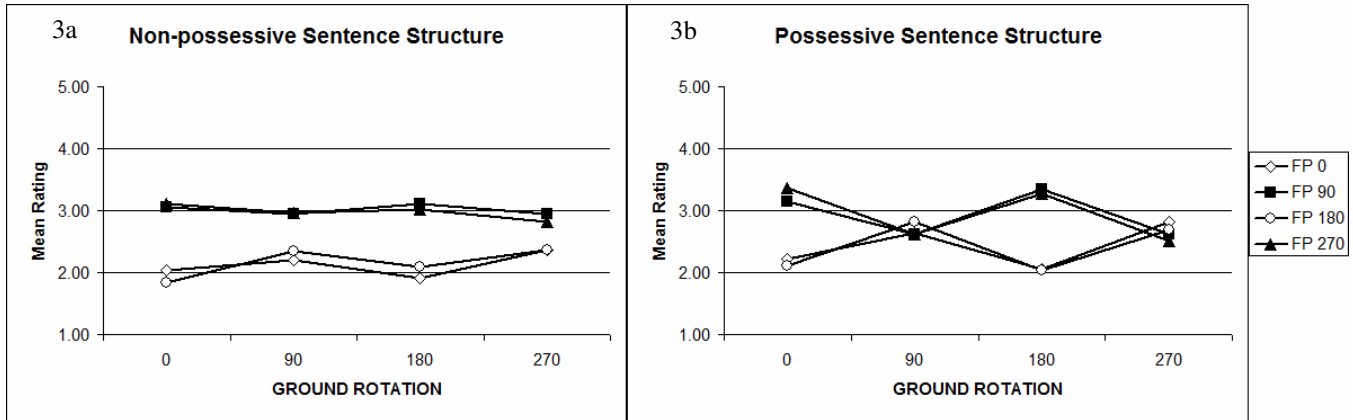

Figures 3a – 3b. Mean sentence acceptability ratings for the 16 figure position/ground rotation arrangements broken down by Sentence Structure and collapsed across Term and Frontedness.

3.107,  $p < .05$ . At the two ground rotations where the VC frame was out of alignment with the OC frame, the average rating of all VC-consistent arrangements (FP 90-GR 90, FP 270-GR 90, FP 90-GR 270, FP 270-GR 270) ( $M = 2.922$ ) was significantly higher than the average rating of all OC-consistent arrangements (FP 0-GR 90, FP 180-GR 90, FP 0-GR 270, FP 180-GR 270) ( $M = 2.314$ ) for the non-possessive sentence structure,  $t(14) = 3.183$ ,  $p < .05$ . However, these average ratings did not differ within the possessive condition (VC assignments,  $M = 2.593$ , vs OC assignments,  $M = 2.737$ ,  $t(10) = -.641$ ,  $ns$ ). This effect is in line with the prediction that the possessive sentence structure may facilitate consideration of an OC frame of reference by increasing ratings of OC assignments and/or decreasing ratings of VC assignments to the point at which the two frames are equally acceptable.

### Frontedness

Figures 4a and 4b show that Frontedness influenced the pattern of acceptability across the figure position-ground

rotation combinations,  $F(9, 207) = 13.555$ ,  $p < .05$ , much as Sentence Structure did. For non-fronted objects, the average rating of all VC-consistent arrangements at the two ground rotations where the VC frame was out of alignment with the OC frame was significantly higher ( $M = 3.218$ ) than the average rating of all OC-consistent arrangements ( $M = 2.342$ ),  $t(24) = 5.054$ ,  $p < .05$ ; however, for the fronted objects, no difference was found (VC assignments,  $M = 2.336$ , vs OC assignments,  $M = 2.659$ ,  $t(24) = -1.353$ ,  $ns$ ). As was the case for the possessive sentence structure, the inclusion of a fronted ground object appears to equalize the acceptability of a VC interpretation and the acceptability of an OC interpretation.

### Sentence Structure and Frontedness

The combination of the influence of Sentence Structure and Frontedness is evident in the five-way interaction of Term, Sentence Structure, Frontedness, Figure Position and Ground Rotation;  $F(9, 207) = 5.444$ ,  $p < .05$ . For the sake of brevity, and because results for the terms *left* and

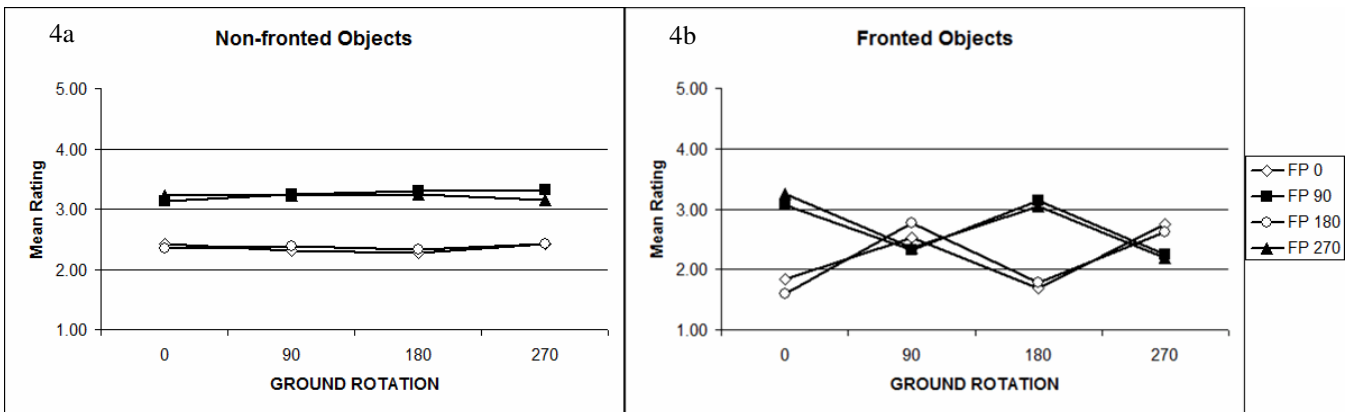

Figures 4a – 4b. Mean sentence acceptability ratings for the 16 figure position/ground rotation arrangements broken down by Frontedness and collapsed across Term and Sentence Structure.

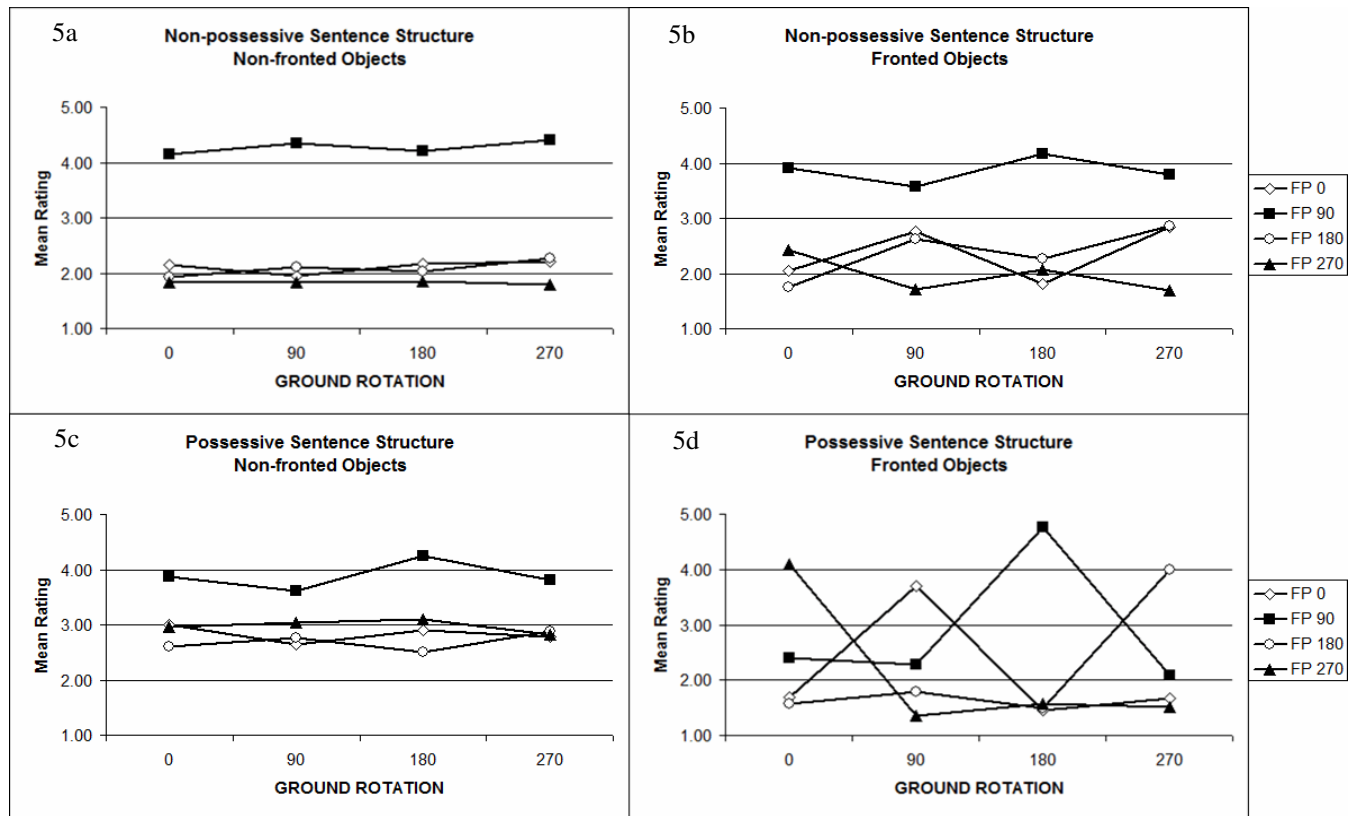

Figures 5a – 5d. Mean sentence acceptability ratings for the 16 figure position/ground rotation arrangements broken down by Sentence Structure and Frontedness for the term *right*.

*right* were similar, here we only describe the analysis of *right* (see Figures 5a – 5d).

**The Viewer-centered frame.** In order to further understand the way in which the variables of Sentence Structure and Frontedness influenced the acceptability of *right* for arrangements consistent with a VC frame of reference (FP 90), we examined changes in acceptability ratings across the different levels of Sentence Structure and Frontedness<sup>2</sup>. Looking at the acceptability ratings for these points across the 4 conditions (Figures 5a – 5d), we observe that VC points are rated as most acceptable for the non-possessive, non-fronted condition (5a) and for the possessive, non-fronted condition (5c), with lower acceptability in the non-possessive, fronted condition (5b), and with lowest acceptability in the possessive, fronted condition (5d). These differences in acceptability are significant (non-possessive, non-fronted vs. possessive, non-fronted,  $M = 3.767$ ,  $t(23) = 1.326$ ,  $ns$ ; non-possessive, non-fronted,  $M = 4.301$ , vs. non-possessive, fronted,  $M = 3.754$ ,  $t(13) = 2.508$ ,  $p < .05$  one-tailed; non-possessive, non-fronted vs. possessive, fronted,  $M = 2.252$ ,  $t(23) = 4.463$ ,  $p < .05$ ; non-

possessive, fronted vs. possessive, fronted,  $t(23) = 3.040$ ,  $p < .05$ ).

**The Object-centered frame.** In order to further understand how the variables of Sentence Structure and Frontedness influenced the acceptability of *right* for arrangements consistent with an OC frame of reference (FP 270-GR 0, FP 0-GR 90, FP 180-GR 270) (see Figure 2 for representations of these arrangements), we examined changes in acceptability ratings across the different levels of Sentence Structure and Frontedness for these arrangements. Looking at acceptability ratings across the different conditions reveals that OC points received the highest ratings in the possessive, fronted condition (Figure 5d). Ratings were lower in the non-possessive, fronted (5b) and possessive, non-fronted conditions (5c) and lowest in the non-possessive, non-fronted condition (5a). These differences in acceptability are significant (possessive, fronted vs. non-possessive, fronted,  $M = 2.683$ ,  $t(23) = -2.421$ ,  $p < .05$ ; possessive, fronted,  $M = 3.930$  vs. possessive, non-fronted,  $M = 2.828$ ,  $t(10) = -2.366$ ,  $p < .05$ ; non-possessive, fronted vs. possessive, non-fronted,  $t(23) = -.296$ ,  $ns$ ; possessive, non-fronted, vs. non-possessive, non-fronted,  $M = 2.015$ ,  $t(23) = -2.184$ ,  $p < .05$ ).

<sup>2</sup> For this and following analyses, we excluded data for GR 180, as at this ground rotation the VC and OC frames are in alignment.

**Comparing the two types of reference frame.** To test our prediction that the combination of a possessive sentence structure and fronted object would create a situation in which OC assignments would be rated as more acceptable than VC assignments—and that this effect would be unique to this combination—we compared ratings of OC assignments to ratings of VC assignments in each condition. For the non-possessive, non-fronted condition, the average rating of VC arrangements ( $M = 4.301$ ) was higher than the average rating of OC arrangements ( $M = 2.015$ ),  $F(1, 13) = 22.718$ ,  $p < .05$ . For the possessive, fronted condition, the average rating of the OC arrangements ( $M = 3.930$ ) was significantly higher than the average rating of the VC arrangements ( $M = 2.252$ ),  $F(1, 10) = 6.698$ ,  $p < .05$ . Average ratings of the VC arrangements and the OC arrangements did not differ for either of the remaining conditions.

Considered individually, both the possessive sentence structure and the fronted objects appear to raise the salience of the OC frame of reference as evidenced by an increase in acceptability ratings for OC-consistent arrangements and/or a decrease in acceptability ratings for competing VC-consistent arrangements. Figures 3 and 4 show this effect. However, the lack of difference between average ratings of the VC and OC assignments suggest that the simple act of incorporating a possessive sentence structure or a fronted object may only cause the OC frame to be as acceptable as the VC frame. In contrast, the combination of a possessive sentence structure and fronted ground object both decreases acceptability of VC assignments and increases acceptability of OC assignments to the point in which English speakers prefer an OC assignment to a VC assignment (at least when these assignments are in competition).

## Conclusions

In this paper, we examined two factors that may influence how a reference frame is selected for a spatial description. Taken together, the results from this study provide more insight into the nature of viewers' consideration of the VC and OC frames of reference. When the non-possessive sentence structure is used to describe a scene in which a non-fronted object serves as the ground, viewers prefer a VC assignment over an OC assignment. When either a possessive structure or a fronted object is introduced, VC and OC assignments appear equally appropriate. Finally, when both a possessive structure and a fronted object are introduced, a preference for OC assignments over VC assignments arises. These results support our predictions that, as Levinson (1996, 2003) argues, VC assignments are the default for English speakers, but consideration of other assignments may increase when certain elements of the situation are changed in order to call attention to the ground object's inherent features (Carlson-Radvansky & Irwin, 1993, 1994). The inclusion of a possessive sentence structure and/or a fronted object appears to do

just that. When a fronted object serves as the point of reference, the asymmetries associated with this type of object's axial structure (Landau & Jackendoff, 1993) may point out to the viewer that this object might have its own perspective, different from that of the viewer, which can also be used to assign space. Additionally, in support of Vandeloise's (1996), Levinson's (1996), and Levelt's (1996) claims, the use of a possessive sentence structure to describe the scene may also highlight any asymmetries associated with the ground object and similarly cause viewers to notice potentially competing perspectives. However, neither of these factors alone leads to a preference for one type of reference frame over the other. Rather, the inclusion of either factor on its own only seems to equalize the acceptability of the two reference frames, while preference for an OC assignment appears when there is a combination of a fronted ground object and possessive sentence structure.

## Acknowledgments

We would like to thank the members of the Language and Cognition Lab at UL Lafayette for their comments.

## References

- Carlson-Radvansky, L.A. & Irwin, D.E. (1993). Frames of reference in vision and language: Where is *above*? *Cognition*, *46*, 223-244.
- Carlson-Radvansky, L.A. & Irwin, D.E. (1994). Reference frame activation during spatial term assignment. *Journal of Memory and Language*, *33*, 646-671.
- Landau, B. & Jackendoff, R. (1993). "What" and "where" in spatial language and spatial cognition. *Behavioral and Brain Sciences*, *16*, 217-265.
- Levelt, W. J. M. (1996). Perspective taking and ellipsis in spatial descriptions. In Bloom, P., Peterson, M.A., Nadel, L., & Garrett, M.F. (Eds.) *Language and space* (pp. 77-107). Cambridge, MA: The MIT Press.
- Levinson, S.C. (1996). Frames of reference and Molyneux's question. In Bloom, P., Peterson, M.A., Nadel, L., & Garrett, M.F. (Eds.) *Language and space* (pp. 109-170). Cambridge, MA: The MIT Press.
- Levinson, S.C. (2003). *Space in language and cognition: Explorations in cognitive diversity*. Cambridge: Cambridge University Press.
- Majid, A., Bowerman, M., Kita, S., Haun, D., & Levinson, S. (2004). Can language restructure cognition? The case for space. *Trends in Cognitive Science*, *8*, 108-114.
- Miller, G.A. & Johnson-Laird, P.N. (1976). *Language and perception*. Oxford, England: Harvard University Press.
- Retz-Schmidt, G. (1988). Various views on spatial prepositions. *AI Magazine*, *9* (2), 95-105.
- Vandeloise, C. (1991). *Spatial prepositions: A case study from French*. (A.R.K. Bosch, Trans.) Chicago: University of Chicago Press.